

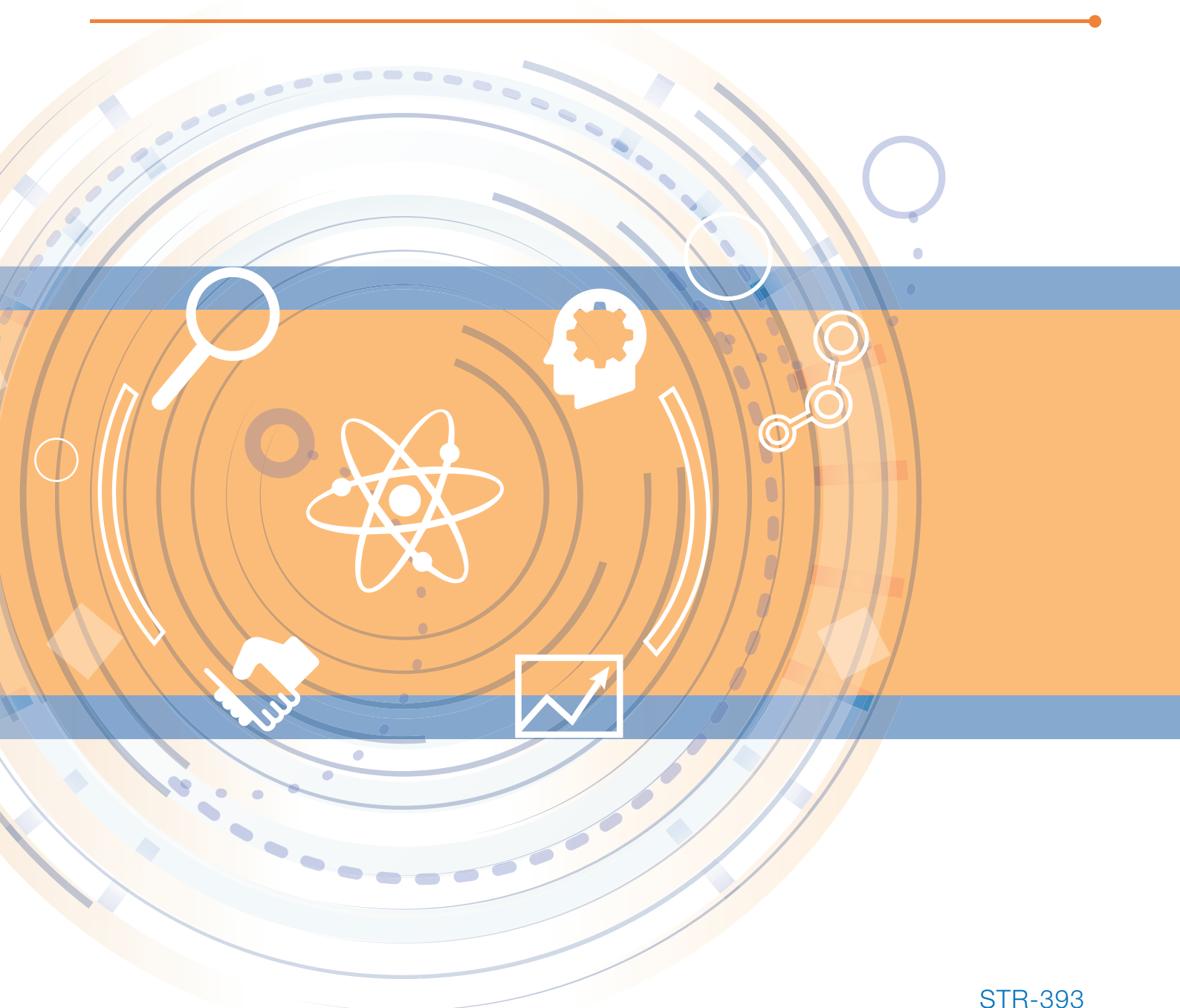

Safeguards

Development and Implementation Support Programme for Nuclear Verification 2020–2021



STR-393
January 2020

Foreword



Staying ahead in nuclear verification is not an easy task. The IAEA has no dedicated budget for research and development. Nor does it have its own specialized training facilities to train new Safeguards inspectors or field test emerging technical advances. Moreover, a combination of increasing demand and a static budget result in some difficult decisions on resources and priorities.

How then, is the IAEA able to maintain its verification responsibility as the world's nuclear inspectorate in support of global efforts to prevent the spread of nuclear weapons?

The answer lies with the 21 Member State Support Programmes (MSSPs), which provide much needed financial and in-kind support through extrabudgetary contributions. I cannot stress enough the importance of MSSPs to the continuous development of our capabilities and the strengthening of our ability to address current and emerging challenges. Another potential avenue of available extrabudgetary contributions is via non-traditional partners, which is an exciting new initiative planned for this biennium.

In light of the importance of encouraging existing contributors and

attracting new ones, it has become increasingly necessary to provide a comprehensive picture of the activities where extrabudgetary contributions and technical support are needed.

Financial and in-kind contributions help us across a diverse range of technical areas, from implementing new, in-field verification systems, to enhancing our destructive analysis capabilities, to ensuring the confidentiality of information entrusted to the Department, and so much more.

To communicate our most urgent, short-term, extrabudgetary needs, the Department publishes this document, the *Development and Implementation Support (D&IS) Programme for Nuclear Verification*. We hope that you will use the document to understand our short-term D&IS needs and to inform your decision-making about how best to allocate extrabudgetary contributions.

Our Member States are counting on us to deliver credible safeguards conclusions each and every year. I look forward to strengthening our successful working partnerships with them in this biennium and beyond.

A handwritten signature in black ink, appearing to read 'Massimo Aparo'.

Massimo Aparo
Deputy Director General
Head of the Department of
Safeguards

Contents

Foreword	1
Introduction	3
Member State Support Programmes.....	8
Observers	8
D&IS Project Managers	9
Top Priorities for 2020–2021 by D&IS Project	10
Overview of Expected Outcomes and Key Outputs.....	16
DDGO-001: Overall Safeguards Management and Coordination.....	43
SGAS-001: Destructive Analysis of Nuclear Materials.....	49
SGAS-002: Environmental Sample Analysis Techniques	56
SGAS-003: Analysis Support and NWAL Coordination	64
SGCP-003: Safeguards Approaches	74
SGCP-004: Strategic Planning and Partnerships.....	83
SGCP-101: Quality Management	90
SGCP-102: Training.....	97
SGIM-002: Satellite Imagery Analysis	110
SGIM-003: Information Analysis.....	117
SGIM-007: Evaluation of Data from Environmental Sampling and Material Characterisation....	126
SGIM-008: Statistical Analysis	134
SGIM-009: State-Declared Information Management.....	144
SGIS-002: Information Security and Infrastructure	150
SGIS-003: Safeguards Information Systems and System Usability	159
SGOA-002: Safeguards System for JNFL MOX Fuel Fabrication Plant (J-MOX).....	167
SGOA-003: Fukushima Dai-ichi Safeguards.....	172
SGOC-001: Chernobyl	176
SGTS-001: NDA Techniques	181
SGTS-002: Techniques and Instruments for Sealing and Containment Verification	192
SGTS-003: Surveillance Techniques.....	200
SGTS-008: Instrumentation Technology Foresight	210
SGTS-011: Unattended Measurements Techniques.....	217
SGTS-014: Remote Data Transmission and Processing Systems.....	224
SGVI-001: JCPOA Verification	232
Appendix 1: The Department’s Strategic Plan-on-a-Page.....	234
Appendix 2: R&D Needs with Corresponding D&IS Projects.....	235
Appendix 3: Abbreviations and Acronyms	250

Introduction

The purpose of this biennial document, *Development and Implementation Support (D&IS) Programme for Nuclear Verification 2020–2021*, is to inform the Secretariat, Member States and stakeholders of the IAEA Department of Safeguards' (the Department's) requirements for extrabudgetary support for implementing safeguards in a manner that is effective, efficient and innovative.

This document highlights top priorities and extrabudgetary support needs for 25 safeguards-relevant development and implementation projects. Additionally, this document includes reports on achievements towards the planned outputs and outcomes from the previous biennium. It also serves as the focus of discussions with Member State Support Programme Coordinators.

For some development activities, the resources to implement the *D&IS Programme* come from the Department. For many other development activities and for some implementation activities where expertise and financial resources are not available, support from the Member State Support Programmes (MSSPs), including extra-budgetary contributions from respective Member States, remains essential. The full implementation of the Nuclear Verification Programme would not be possible without the transfer of technology, expertise and resources through the MSSP mechanism.

The Department has prepared its *D&IS Programme* for the biennial period 2020–2021 to prioritize tasks, define key deliverables and inform MSSPs and Departmental resource allocation decisions in the context of the Department's work portfolio.

The *D&IS Programme* aims to meet both short-term needs and others that are part of longer-term R&D planning. It is driven by Department-identified strategic needs, which are assessed against basic scientific information, advances in technology and research, IAEA experience and changes in the operating environment.

The *D&IS Programme* project plans in this document aim to:

- Describe specific short-term D&IS needs and priorities by project area
- Connect short-term needs and activities to the Department's strategic planning framework
- Explain relevant context and background information for new task proposals
- Inform Departmental and MSSP resource allocation decisions

Planning framework

The *D&IS Programme* project plans in this document are designed to contribute to the achievement of the objectives for Major Programme 4 (Nuclear Verification). The Department's three over-arching strategic objectives are:

1. To deter the proliferation of nuclear weapons by detecting early the misuse of nuclear material or technology and by providing credible assurances that States are honouring their safeguards obligations
2. In accordance with the Agency's Statute, assist with other verification tasks, including in connection with nuclear disarmament or arms control agreements, as requested by States and approved by the Board of Governors
3. To continually improve the Department's performance and productivity to effectively carry out the Agency's verification mission

The Department conducts strategic planning, which enhances its capability to face future challenges and benefit from opportunities. The strategic planning framework supports good management of resources through monitoring the operating environment and establishing prioritized objectives; it prevents duplicative work and promotes programmatic and organizational coherence. Another key element of the strategic planning framework is the development, maintenance and enhancement of partnerships with respect to development and implementation support.

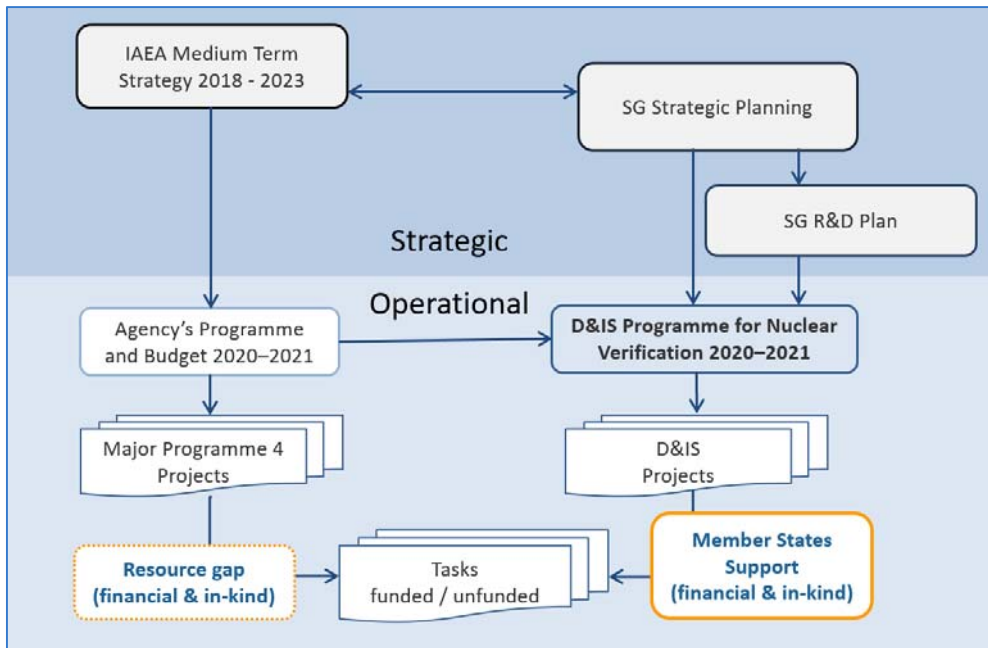

Figure 1: Processes and Documents used to Identify and Address Resource Needs in Safeguards

The Department's strategic planning framework is comprised of the:

- IAEA Medium Term Strategy
- Agency's Programme and Budget
- Department's Strategic Plan
- Safeguards Research and Development (R&D) Plan
- D&IS Programme

The strategic planning framework connects high-level strategic objectives, expected outcomes and relevant R&D needs that require external support with implementation and development tasks that are either fully-funded in the regular budget or need extrabudgetary support. As a result, Department staff and external stakeholders can understand how even the most specialized tasks are connected to the bigger picture of strengthening safeguards capabilities.

Medium Term Strategy 2018–2023 (GOV/2016/57)

The *Medium Term Strategy 2018–2023* (GOV/2016/57), that was taken note of by the Board of Governors, was developed by a working group of the Board of Governors with the assistance of the Secretariat. The *Medium Term Strategy* guides the development of the *Agency's Programme and Budget* during the three biennia covered by it. It identifies priorities among and within its programmes for the achievement of the Agency's statutory objectives in an evolving international environment. Find the *Medium Term Strategy 2018–2023* at <https://www.iaea.org/about/overview/medium-term-strategy>.

Agency's Programme and Budget 2020–2021 (GC(63)/2)

The *Agency's Programme and Budget 2020–2021* (GC(63)/2) that was approved at the General Conference in 2019 describes all approved activities that need to be carried out during the biennium. It also contains the approved budget that will be allocated to each of these activities. Several tasks of the programme remain unfunded. For the Department, this unfunded part amounts to €65.6 million over the 2020–2021 biennium, up from €45.7 million from the previous biennium. In addition to these unfunded resources (human or material), there is a substantial amount of other resources that cannot be easily tallied but are still essential for effective implementation of the verification mandate. These resources are, for example, new equipment and software resulting from R&D activities performed in Member States, the availability of nuclear facilities for testing or training purposes and the contributions of external experts. For more information about Major Programme 4: Nuclear Verification and other Major Programmes, go to <https://www.iaea.org/sites/default/files/gc/gc63-2.pdf>.

Safeguards Strategic Planning

The external environment analysis and scenarios upon which Safeguards Strategic Planning is based examines the Agency's operating environment until the year 2030. Strategic Planning prepares the Department for changes in the operating environment, provides direction and sets priorities. It helps SG improve the way it operates so that the Department can meet Member States' expectations for effectiveness and efficiency. The Plan-on-a-page ([Appendix 1](#)) outlines departmental objectives in four focus areas:

- Delivering on the mission
- Managing intellectual capital
- Enhancing organizational performance
- Partnering for success

R&D Plan (STR-385)

The *R&D Plan* supports the implementation of the Department's priority strategic objectives by highlighting specific needs that are reliant on external support. The *R&D Plan* and the *D&IS Programme* both refer to the priority strategic objectives. In this way, all tasks have a clear connection to Departmental strategies for improving capabilities in pursuit of its mission. Find the electronic version of the R&D Plan at <https://www.iaea.org/sites/default/files/18/09/sg-str-385-research-and-development-plan.pdf>.

The D&IS Programme (STR-393) (this document)

The *D&IS Programme* gives a detailed and technical description of the Department's technical development and implementation efforts that require support from external partners. Each technical area, known as a D&IS project, links its objectives to the Department's strategic planning framework. Find the electronic version of the *D&IS Programme* at <https://sprics.iaea.org/api/StaticContent/external/Resources.html> (SPRICS users only at time of publication).

D&IS Programme scope

The *D&IS Programme* contains two types of activities:

- Activities that address development of *new* techniques and technologies
- Activities that support the deployment, maintenance, implementation or improvement of *existing* capabilities.

This *D&IS Programme* endeavours to describe *all* development activities being undertaken within the Department in each D&IS project regardless of the funding source. This is an important part of ensuring that stakeholders have a complete picture of relevant work towards a given objective. This, in turn, will help stakeholders understand where extrabudgetary contributions can make the greatest impact: by complementing existing efforts and/or avoiding duplicative work.

The *D&IS Programme's* development activities aim at, inter alia:

- *New capabilities* identified through the Department's planning processes that address emerging and future needs.
- *Continual improvement* of the Department's processes, equipment/systems, tools, training, concepts and approaches, analysis services, information acquisition, analysis and evaluation capabilities.
- *Technology enhancement* with efforts that focus on the Department's core capabilities and technologies, such as the development and customization of equipment.

In the area of safeguards implementation, the *D&IS Programme* covers MSSP-supported tasks that would otherwise remain unfunded. The *Agency's Programme and Budget* covers all other implementation-related work.

The *D&IS Programme's* implementation support activities aim primarily at:

- *Sustainability* efforts that focus on the Department's need to sustain core capabilities and technologies (for example, training for inspectors, refinement or replacement of equipment and systems)
- *Increased capacity* efforts needed due to an increased demand for verification activities or short-term projects (for example, laboratory analytical services, IT services or training).

Programme and project management

The Department's Division of Concepts and Planning coordinates D&IS activities. For the 2020–2021 biennium, the Programme has 25 projects that meet current and emerging safeguards needs.

The execution of the programme is performed through tasks planned within the D&IS project plans that are described in the main body of this document. For tasks involving MSSPs, the work is performed through Support Programme tasks. Each task has an IAEA and MSSP representative assigned to oversee the work.

Significant changes to the D&IS Programme for 2020–2021

New and discontinued projects

There are no new projects or discontinued projects in this biennium.

DDGO-001: Overall Safeguards Management and Coordination, which was published as an addendum to the previous programme in October 2018 (STR-386.1), is included in this document.

Project title updates

Project ID	Previous Title	Updated title
SGIM-002	Geospatial Information Analysis	Satellite Imagery Analysis
SGOC-001	Chernobyl	Chornobyl
SGTS-014	Remote Monitoring and Data Processing Systems	Remote Data Transmission and Processing Systems
SGVI-001	JCPOA Implementation	JCPOA Verification

Project plan outline

Each project plan has an updated overview, strategy framework linkages, plans for 2020–2021, in-house development task tables and attachments. One new section to the outline reports on progress from the previous biennium's outcomes and outputs. Each project plan has the following components:

Section #	Section Title	Section Description
1.	Overview	<ul style="list-style-type: none"> Main objective and importance of work to the Department Challenges in the next 10 years Top priorities for the next 2 years
2.	Strategy framework linkages	<ul style="list-style-type: none"> Project's link to IAEA's Programme and Budget Project's link to the Department's Strategic and R&D Plans
3.	Progress on expected outcomes, key outputs and tasks from previous biennium (New section in the 2020–2021 biennium document)	<p>A review of expected outcomes and key outputs planned in 2018–2019, their status and comments</p> <p>Possible statuses are:</p> <ul style="list-style-type: none"> Key output achieved; work completed Key output achieved; work continues Delayed; nearing completion Delayed; work in progress On hold Cancelled
4.	Expected outcomes, key outputs and tasks for 2020–2021 biennium	Project's expected outcomes and key outputs planned in 2020–2021 and plans for accomplishing the expected outcomes
5.	In-house development tasks	Internal development activities supported with regular budget funds that will continue, but which would benefit from external contributions to the project
6.	Attachments	Visuals that display the work of the project

Administration of the Member State Support Programme

MSSP task proposals (SP-1s) and tasks are administered by the Department's Support Programme Coordination Team (SPCT) in the Section for Strategic Planning and External Coordination (CPC), Division of Concepts and Planning (SGCP) together with MSSP Coordinators. The appointed MSSP Coordinators are the IAEA's main points-of-contact for each MSSP.

Task lifecycle

Department staff write task proposals, which are requests for Member State support. The SPCT transmits Department-approved task proposals to relevant MSSPs Coordinators. When an MSSP accepts a task proposal, then the Department and the MSSP activate a new task and assign an IAEA Task Officer and an MSSP Point of Contact (POC).

The Task Officer hosts a task kickoff meeting and, in consultation with the MSSP POC, finalizes the task plan. Together, the IAEA and MSSP execute the task plan, write status reports and meet at least annually at Annual Review Meetings to discuss progress.

When the IAEA and MSSP achieve the task objective, then the Task Officer documents the task outcomes, how task outcomes were met, lessons learned and how the Department is applying the task outcomes.

Administrative system

The Support Programme Information and Communication System (SPRICS) is the repository and information exchange mechanism for the MSSP. SPRICS stores up-to-date task proposal and task information, meeting information and general Support Programme information. SPRICS is in IAEA's NUCLEUS Catalogue, along with dozens of other scientific, technical and regulatory systems. MSSP Coordinators, points of contact and representatives can find lists and summaries of MSSP task proposals (SP-1s) and tasks on SPRICS. To request access to SPRICS, please contact SPRICSHelp@iaea.org.

Reporting and review of the Member State Support Programme

The Department holds annual and semi-annual Support Programme review meetings with individual MSSPs to review the status of their Support Programmes and progress on tasks.

Task Officers and MSSP POCs write status reports on active tasks for review meetings. When a task is complete, the task officer writes a report on completed task and submits it to the involved MSSP. Reports and meeting records are in SPRICS.

The biennial MSSP Coordinators' Meeting is also held for MSSPs and Department staff to discuss the overall programme and topics of general interest.

Collaboration on IT development projects

Most D&IS project managers have planned IT developments in applications in 2020–2021. When IT development is supported by a MSSP, the D&IS project manager will collaborate with project SGIS-003: Safeguards Information Systems and System Usability to ensure compliance with SGIS IT governance, standards and best practices. The alignment of IT development across the departmental facilitates the integration, integrity, security and availability of safeguards data.

The future

The Department will continue to rely on MSSPs to provide the necessary technology, expertise and resources to meet its research, development and implementation support needs. In recognizing a potential benefit in engaging non-traditional partners, the Department is also considering a 'non-traditional partnership coordination programme' to mobilize and direct support from non-traditional partners to the Department, as suggested in the 2018 Safeguards Symposium Report (STR-392).

Over the 2020–2021 biennium, the Department will continue to further align the planning and implementation process for D&IS activities with Departmental strategic planning and the *R&D Plan*. Efforts to maintain and extend existing partnerships and identify new ones will be continued for the benefit of the Agency's successful implementation of the verification mandate.

Member State Support Programmes

Abbreviation	Title
ARG SP	Argentine Support Programme
AUL SP	Australian Support Programme
BEL SP	Belgian Support Programme
BRZ SP	Brazilian Support Programme
CAN SP	Canadian Support Programme
CPR SP	Chinese Support Programme
CZ SP	Czech Republic Support Programme
EC SP	European Commission Support Programme
ESP SP	Spanish Support Programme
FIN SP	Finnish Support Programme
FRA / FRESPAS	French Support Programme
GER SP	German Support Programme
HUN SP	Hungarian Support Programme
JPN / JASPAS	Japan Support Programme
NET SP	Netherlands Support Programme
ROK SP	Republic of Korea Support Programme
RSA SP	Republic of South Africa Support Programme
RUS SP	Russian Federation Support Programme
SWE SP	Swedish Support Programme
UK SP	United Kingdom Support Programme
USA / USSP	United States of America Support Programme

Observers

Abbreviation	Title
EURATOM	European Atomic Energy Community
ABACC	Brazilian-Argentine Agency for Accounting and Control of Nuclear Materials

D&IS Project Managers

Project ID	Project Title	Project Manager
DDGO-001	Overall Safeguards Management and Coordination	CLAUDE, Frederic
SGAS-001	Destructive Analysis of Nuclear Materials	BALSLEY, Steven
SGAS-002	Environmental Sample Analysis Techniques	KILBURN, Matthew
SGAS-003	Analysis Support and NWAL Coordination	Not available
SGCP-003	Safeguards Approaches	DOO, Jin Yong
SGCP-004	Strategic Planning and Partnerships	PUJOL, Eric
SGCP-101	Quality Management	FITZGERALD, Roy
SGCP-102	Training	PICKETT, Susan
SGIM-002	Satellite Imagery Analysis	LAFITTE, Marc
SGIM-003	Information Analysis	AUBERT, Brian
SGIM-007	Evaluation of Data from ES and Material Characterisation	NIKKINEN, Mika
SGIM-008	Statistical Analysis	BINNER, Robert
SGIM-009	State Declared Information Management	KONECNI, Snezana
SGIS-002	Information Security and Infrastructure	PARTEE, Scott
SGIS-003	Safeguards Information Systems and System Usability	WHITAKER, Gregg
SGOA-002	Safeguards System for JNFL MOX Fuel Fabrication Plant (J-MOX)	CREUSOT, Christophe
SGOA-003	Fukushima Dai-ichi Safeguards	CHESNAY, Bruno
SGOC-001	Chornobyl	KURSELIS, Sigitas
SGTS-001	NDA Techniques	MAYOROV, Mikhail
SGTS-002	Techniques and Instruments for Sealing and Containment Verification	WISHARD, Bernard
SGTS-003	Surveillance Techniques	LAVIETES, Tony
SGTS-008	Instrumentation Technology Foresight	FINKER, Dimitri
SGTS-011	Unattended Measurements Techniques	POCHET, Thierry
SGTS-014	Remote Data Transmission and Processing Systems	ALESSANDRELLO, Angelo
SGVI-001	JCPOA Verification	CATTON, Andy

Top Priorities for 2020–2021 by D&IS Project

DDGO-001: Overall Safeguards Management and Coordination

- Develop the Department's capacity to strategically manage its assets (aligned with International Organization for Standardization (ISO) 55000, ISO 50001, ISO 50002 and International Public Sector Accounting Standards (IPSAS)) through new and updated guidelines, procedures, information system enhancements, inventory data cleansing, staff training and raising staff awareness.
- Increase the effectiveness of internal communication.

SGAS-001: Destructive Analysis of Nuclear Materials

- Install and validate new software for the controlled potential coulometry system in the Nuclear Material Laboratory (NML).
- Conduct feasibility testing of microcalorimetry techniques for uranium and plutonium analysis.
- Develop and implement new algorithms for the hybrid k-edge densitometry (HKED) system for the On-Site Laboratory (OSL).
- Maintain supplies of reference materials and quality control standards for existing and new analytical techniques.

SGAS-002: Environmental Sample Analysis Techniques

- Development of new methodologies for the age determination of particles in environmental samples using large geometry-secondary ion mass spectrometry (LG-SIMS).
- Development of new methodologies for using the Scanning Electron Microscope (SEM) and Time-of-Flight (ToF) Secondary Ion Mass spectrometry (SIMS) capability to characterize individual particles collected on environmental swipe samples.
- Implementation of the Laser-Ablation ICP-MS technique for the measurement of particles containing low levels of Pu or mixed U/Pu.

SGAS-003: Analysis Support and NWAL Coordination

- Ensure efficient and effective operation of the Network of Analytical Laboratories (NWAL), including participation in inter-laboratory comparison exercises.
- Expand the NWAL, with the main focus on overall capacity and quality assurance of particle analysis of environmental samples.
- Increase capacity for the safe and secure shipment of nuclear material samples and disposal of analytical residues.

SGCP-003: Safeguards Approaches

- Develop methodologies and guidance to standardize and improve the internal processes for conducting acquisition path analysis, developing State-level safeguards approaches (SLAs) and evaluating the effectiveness of safeguards implementation.
- Develop effective and efficient safeguards concepts early in the design process of new types of facilities including Small Modular Reactors (SMRs).
- Develop safeguards implementation guidelines for facilities under decommissioning and safeguards concepts for post-accident facilities under decommissioning.

SGCP-004: Strategic Planning and Partnerships

- Develop processes, methods and tools to strengthen foresight, enabling changes in the operating environment to be identified, monitored, analysed and addressed at an early stage.
- Further institutionalize existing processes, methods and tools for executing the Department's strategic plan, to ensure their sustainability.
- Mobilize traditional and non-traditional partnerships and further align their support to address safeguards priorities.

SGCP-101: Quality Management

- Continue to improve and mature the process-based approach implemented in the Department.
- Upgrade the Quality Management System (QMS) tools and techniques for improving and monitoring process performance.

- Continually assess the effectiveness of the Department's QMS and implement improvements as needed.

SGCP-102: Training

- Customized training
 - Develop a systematic approach to training and ensure access to current and new nuclear fuel cycle facilities for training purposes.
 - Develop competency-based training paths (in other words, sample curricula) for various job roles.
 - Provide targeted national State Systems of Accounting for and Control of Nuclear Material (SSAC) training, through a competency-based approach, based on a training needs assessment and outcomes of State Systems of Accounting for and Control of Nuclear Material (ISSAS) missions and SSAC self-assessment tools.
- Consistency of approach
 - Ensure the consistent application of Systematic Approach to Training (SAT) principles for in-house and Member State training, to ensure high quality training.
 - Review and ensure the use of collaborative learning methods in all courses and complement the classroom training with existing and future e-learning modules, as appropriate. Blended learning opportunities—using a combination of electronic, online and classroom or face-to-face activities—might also be considered, subject to available resources.
 - Integrate some blended learning, including e-learning; content creation; virtual tools and self-directed learning, to address diverse educational needs.
- Enhanced access
 - Develop the content, teaching approach and overall delivery of e-learning or self-guided learning, so that learning opportunities are more readily accessible and reach a wider audience and in order to help build the knowledge and skills necessary for effective safeguards implementation.
 - Continue integration of safeguards training material in the IAEA e-learning platform (CLP4NET, a Moodle-based system), building on the already successful system used for many SSAC training activities.
- Improved monitoring and recording
 - To improve the effectiveness of training and ensure departmental staff members development plans keep pace with challenges, Safeguards Training (CTR) must track the training provided/received and training evaluations in an accessible, usable system capable of providing timely reports and statistics on request—either for training course design or for IAEA high-level reports such as the Safeguards Implementation Report and the Annual Report. CTR receives on average 5–7 requests per month for statistics, and Divisional Training officers require such information on a daily basis to ensure staff training plans can be properly implemented.
 - Together with the internal parties responsible, development of an integrated learning management system is required, to establish staff training paths for departmental staff members and monitor learning progress. An integrated learning management system should also provide departmental staff members with access to the Departmental Training Programme and retain training records. This would also facilitate reporting and significantly contribute to the planning and evaluation of training.

SGIM-002: Satellite Imagery Analysis

- Maintain and enhance in-house satellite imagery and geospatial analytical processes and capabilities.
- Enhance and develop in-house competencies to better support the State evaluation process.
- Promote dissemination of satellite imagery and geospatial analysis and collaborative analysis within the Department through interoperability with in-house systems.

SGIM-003: Information Analysis

- Develop a capability within the Open Source Information System (OSIS), the current optimized collection system, to provide autonomous browsing of the Internet to identify and return safeguards-relevant information.
- Enhance the automated collection, processing and management of safeguards-relevant open source information in OSIS, including mechanisms for adding structure to unstructured data.
- In collaboration with project SGIS-003, develop and implement a modern software package, the Technical Assistance Review System (TARS), to facilitate the assessment of potential safeguards-relevant activities and procurements associated with the provision of Agency technical assistance to Member States.
- Optimize the use of multimedia information collection, analysis and integration in State evaluation and preparation for infield activities, through the deployment of specialized tools, methods and procedures.
- Continue to integrate open source datasets with other safeguards-relevant information and systems, including for declared information consistency analysis and infield activity preparation, to enable its use in techniques such as link analysis and geospatial visualization and to develop all necessary use cases and procedures.

SGIM-007: Evaluation of Data from ES and Material Characterisation

- Explore and develop statistical techniques and evaluation methodologies that improve data evaluation and the application of signatures detectable through Environmental Sampling (ES) and material characterisation, including the use of elemental and morphological data.
- Expand current understanding of the detectable signatures (isotopic, elemental and morphological characteristics of key materials) from nuclear fuel cycle (NFC) activities, including the formation, transport and transformation of particles in the environment.
- Complete the migration of the Environmental Sampling Database (ESDB) to Oracle 12c.

SGIM-008: Statistical Analysis

- Standardized methodologies, in support of State Level Approaches, for calculating detection probabilities achieved through verification activities, at both facility and State levels. The aim here would be to support the determination of frequencies and intensities of quantitative verification activities and to evaluate their effectiveness.
- Improved and harmonized random inspection schemes (including short notice random inspections (SNRIs)) and methodologies developed to evaluate their effectiveness.
- Further development of sampling methodologies and practical implementation procedures for these methodologies.
- Further enhancement of software and visualization tools to support the design, implementation and evaluation of safeguards approaches and related verification activities.

SGIM-009: State Declared Information Management

- Update and deploy tools and methodologies for States to collect, store and submit State-declared information.
- Enhance the State Declarations Portal (SDP) as a tool for information exchange between States and the IAEA.
- Enhance State Supplied Data Handling (SSDH) quality checks and produce new types of reports, to support the new State Evaluation Report (SER) template.
- Develop training material and remote delivery methods, to support States or Regional Authorities (SRA) training with reduced costs and increased accessibility.

SGIS-002: Information Security and Infrastructure

- Continuously improve information security by implementing and monitoring critical security controls, testing security systems and installations and addressing the test results and strengthening security operations to prevent, detect and respond to security incidents.
- Ensure authorized user access and prevent unauthorized access to systems and services at all times, across all applications and networks.
- Support the proper and effective use of cryptography to protect the confidentiality, integrity and authenticity of information and ensure that information transferred internally and with external entities is protected from unauthorized disclosure, alteration or destruction.
- Develop secure mobile technology and communications capabilities.
- Prevent unauthorized physical access, damage and interference to the organization's information processing facilities.
- Enhance the Department's ability to recover from an information technology (IT) failure.

- Expand the awareness and capabilities of departmental staff members to maintain effective information security.

SGIS-003: Safeguards Information Systems and System Usability

- Enhance and continuously improve existing IT applications supporting the Department's business, in particular its Services, State-cooperation, Analytical and Verification domain processes.
- Identify and develop new safeguards-relevant software capabilities in line with departmental strategic priorities that will optimize operations.
- Ensure the confidentiality, integrity and availability of safeguards information.

SGOA-002: Safeguards System for JNFL MOX Fuel Fabrication Plant (J-MOX)

- Develop/consolidate a safeguards approach consistent with the State Level Approach (SLA) for Japan.
- Develop/procure equipment necessary to support the safeguards approach.
- Define the requirements specification and architecture for an integrated data collection and evaluation system.

SGOA-003: Fukushima Dai-ichi Safeguards

- Maintain a reliable safeguards system at the Fukushima Dai-ichi site, capable of providing credible assurance that nuclear material cannot be removed from the damaged facilities without the IAEA's knowledge.
- Make improvements and adjustments to the monitoring system, to accommodate changes in the remediation status of the damaged facilities on the site.
- Develop measures to re-verify the previously inaccessible nuclear material as soon as material is made available for verification.

SGOC-001: Chornobyl

- Implement and adjust procedures for safeguards application at facilities under this project.
- Complete the adjustment of safeguards equipment for verification use at Chornobyl site at the Interim (dry) Spent Fuel Storage Facility 2 and the associated Conditioning Facility (ISF-2).
- Complete the installation, adjustment and approbation of safeguards equipment for verification use at the New Safe Confinement (NSC).

SGTS-001: NDA Techniques

- Improve the effectiveness of non-destructive assay (NDA)-based verification activities, without reducing their efficiency, through the application of:
 - Fast Neutron Coincidence Collar, for active and passive Partial Defect Test (PDT) verifications.
 - Passive Gamma Emission Tomography (PGET) System, in unattended mode.
 - Compact Tomographic Gamma scanner, for inhomogeneous nuclear scrap and waste.
- Enhance the capability for detecting undeclared material and activities, through:
 - Authorization for safeguards use of the Compton and coded aperture gamma camera.
 - Analytical characterisation of the remaining fifteen Nuclear Fuel Cycle (NFC) reference material samples.
- Apply new tools and techniques to routine operations:
 - Ultra-large volume Cadmium-Zinc-Telluride (CDZT) probes, for fresh material verification.
 - Inspector-level integrated data acquisition and analysis software application (MCAT).
 - Infield alpha spectrometers, for nuclear material identification and isotopic composition analysis.
 - Calorimeter, for assay of plutonium samples.
 - New procedures for verification of uranium at bulk facilities, including those based on High-resolution Gamma Spectrometry (HRGS); Raman spectrometry or Laser Induced Breakdown Spectrometry (LIBS).

- Undertake a feasibility study, of fast neutron scanning & imaging techniques for restoration of Continuity of Knowledge (CoK) on light water reactor (LWR) spent fuel casks.

SGTS-002: Techniques and Instruments for Sealing and Containment Verification

- Decreasing IAEA safeguards inspectors' effort in verifying containment on spent fuel storage through more flexible technologies.
- Decreasing efforts during DIVs by more efficient CoK of samples
- Improving the effectiveness and efficiency of passive seals.
- Improving security while decreasing maintenance demands for the replacement of the currently fielded Electronic Optical Sealing System (EOSS).
- Decreasing IAEA safeguards inspectors' exposure to radiation during containment verification of casks.

SGTS-003: Surveillance Techniques

- Complete the initial deployment of the Next Generation Surveillance Review (NGSR) software; a modular and highly efficient surveillance review software tool.
- Implement relevant NGSR functional and user interface revisions, based on operational experience and requested enhancements.
- Initiate the development of advanced surveillance data analysis algorithms, using machine learning and deep learning techniques where appropriate, to provide rapid video review capabilities for large datasets.
- Identify and evaluate safeguards-relevant applications of new and/or emerging technologies, to broaden the capabilities of surveillance by incorporating alternate technologies (for example, Radio Frequency (RF), ultrasonics, acoustics, sonar and hyperspectral imaging).
- Initiate the development of user requirements for the follow-on surveillance technology intended to replace Next Generation Surveillance System (NGSS) in the future.

SGTS-008: Instrumentation Technology Foresight

- Gradually supplement and replace use of the Improved Cerenkov Viewing Device (ICVD) by the Next Generation Cerenkov Viewing Device (XCVD).
- Finalize the development of deployable Robotized Cerenkov Viewing Device (RCVD) carried inside an Unmanned Surface Vehicle (USV).
- Authorize and expand the use of Chemical Identification devices.
- Expand the use of the Multi Components Inspector Kit (MCIK).
- Evaluate the application of 3D mapping combined with radiation imaging.
- Conduct and expand the outreach of Technology Challenges through crowdsourcing platforms.

SGTS-011: Unattended Measurements Techniques

- Deployment of the Unattended Cylinder Verification System (UCVS) in an IAEA-safeguarded Gas Centrifuge Enrichment Plant (GCEP).
- Testing and procurement of the Unattended Data Logger (UDL1), the new generation data acquisition module to be used on most Unattended Monitoring Systems (UMS).
- Upgrading all UMSs with the UDL1, a new computer and a new full direct current (DC) power management system.
- Development of Time Domain Reflectometry (TDR) technology as an electronic tamper-indicating method, to be applied on cabling running from detectors to UMS cabinets.

SGTS-014: Remote Data Transmission and Processing Systems

- Develop the Centralized Automated System for Correlated Analysis and Data Evaluation (CASCADE).
- Continue joint development of the Inspector Review and Analysis Platform (IRAP) and Next Generation Surveillance Review (NGSR), as the foundations of CASCADE, with Euratom.
- Install and test new near real-time (NRT) components for application at large facilities in Ukraine.
- Select and authorise new Virtual Private Network (VPN) hardware for the Remote Data Transmission (RDT) network and, in addition, identify and/or develop an alternative VPN hardware/software with additional security capabilities.
- Continue the practice of requesting security audits of the Remote Monitoring Team (RMT) network.

- Complete the release of ROOGLE3, a program to display real-time RDT system status, with the added feature to monitor hand carried data equipment status and an enhanced capability for integration with other divisional and departmental tools.

SGVI-001: JCPOA Verification

- The top priority is to maintain capabilities for the verification and monitoring of Iran's nuclear-related commitments under the Joint Comprehensive Plan of Action (JCPOA).

Overview of Expected Outcomes and Key Outputs

DDGO-001: Overall Safeguards Management and Coordination

Expected outcome #1	
<p>Department-level strategy and tools for managing the lifecycle of SG assets based on prioritized needs and in alignment with the Agency rules and strategy.</p> <p>Supporting R&D Needs: T.4.R1 and T.4.R2</p>	
Key Outputs	Expected Completion Date
Departmental strategic safeguards asset management plan with updated procedures, guidelines and policies.	May 2020
Asset Management Plans (AMP) for key assets, as per ISO 55000-55002.	May 2021
High-quality inventory data and information systems, to enable data-driven analysis in support of the Department's recapitalization strategy.	December 2020
Expected outcome #2	
<p>Enhanced foresight and decision support on funding needs and budgeting decisions for replacement of safeguards assets.</p> <p>Supporting Priority Objectives: S.1 and C.4</p> <p>Supporting R&D Needs: T.4.R1 and T.4.R.2</p>	
Key Outputs	Expected Completion Date
Draft Departmental strategy for funding renewals of critical safeguards assets.	May 2020
Long-term safeguards capital asset replacement plan to communicate effectively with safeguards stakeholders, including Member States, on potential extrabudgetary needs.	May 2021
Expected outcome #3	
<p>Increased capability for information sharing and greater collaboration.</p> <p>Supporting Priority Objective: C.3</p>	
Key Outputs	Expected Completion Date
Implementation of a Department-specific internal communication strategy to enhance senior leadership and departmental staff member communication capabilities.	December 2021
Updated and implemented internal communication strategy, including review and updated use of Safeguards Portal and new or improved communication channels for feedback, sharing and relationship building.	Continuous
Initiation of communication capacity-building training for departmental staff members.	December 2021
Coordinated development of published communication to ensure consistency of messages conveyed to departmental staff members and to Member States.	Continuous

Expected outcome #4

Increased departmental staff member engagement and satisfaction.

Supporting Priority Objective: S.1 and C.3

Key Outputs**Expected Completion Date**

Results of spot/pulse surveys and communication surveys.

December 2021

Facilitation of departmental staff member focus groups regarding communication.

December 2021

SGAS-001: Destructive Analysis of Nuclear Materials**Expected outcome #1**

Independent verification of Pu amount content in control samples and in-house reference materials through new DA software.

Supporting R&D Need: T.2.R1

Key Outputs**Expected Completion Date**

Installation, testing, validation and training on new software for controlled potential coulometry (CPC) system for Pu assay in NML.

June 2020

Development, testing and implementation of new evaluation software for HKED at the OSL, Japan.

December 2021

Expected outcome #2

Continued independent information for making safeguards conclusions through new analytical methodologies for DA.

Supporting R&D Needs: T.2.R1, T.2.R3 and T.2.R4

Key Outputs**Expected Completion Date**

Developed and validated plutonium/amerium-241 age determination method for nuclear samples containing Pu.

April 2020

A tested, validated and implemented third generation Combined Procedure for Uranium Concentration and Enrichment Assay (COMPUCEA).

December 2020

Implementation of a new scrubber for the OSL that removes radioactive ruthenium gas, which is released during dissolution of high-active liquid waste samples.

December 2021

Implementation of a new stirrer system for the OSL that determines Pu from undissolved particles in high-active liquid waste samples.

December 2021

New and tested microcalorimetry techniques for determining plutonium isotopic mass ratios in very small samples (sub-nanogram range).

December 2021

Testing of the Cristallini UF₆ sampling method in commercial uranium enrichment plants for safeguards samples.

December 2021

SGAS-002: Environmental Sample Analysis Techniques

Expected outcome #1	
<p>Provision of external quality control and reference materials, as well as technical expertise, through optimized utilization of the expanded NWAL.</p> <p>Supporting R&D Needs: T.2.R2 and T.2.R4</p>	
Key Outputs	Expected Completion Date
Reports from Technical Meetings, the Working Group and 'Friends of SAL' containing recommendations for the provision of particle QC material.	December 2021 and ongoing
Additional reference and QC materials (about one per year) to be made available for internal and external quality control programmes administered through the NWAL.	December 2021 and ongoing
Expected outcome #2	
<p>Improved detection of signatures of undeclared nuclear activities in environmental samples through the development, implementation and improvement of techniques, methods and equipment.</p> <p>Supporting R&D Need: T.2.R6</p>	
Key Outputs	Expected Completion Date
Implementation of the laser ablation-inductively coupled plasma mass spectrometry (LA-ICP-MS) technique to analyse Pu and mixed U/Pu particles in environmental samples.	December 2020
Implementation of identification methods to find and isolate Pu-containing particles for analysis by LA-ICP-MS, including Fission-Track techniques, LG-SIMS and SEM.	December 2020
Development and implementation of a methodology for the elemental analysis of particles using the ToF-SIMS capability of the ESL's TESCAN Lyra SEM.	December 2021
Development and implementation of methodologies for the age determination of particles using LG-SIMS.	December 2021
Report on a feasibility study to enhance the sensitivity of detection of U and Pu isotopes using mass spectrometry methods.	December 2021
Expected outcome #3	
<p>Ensured sustainability of the ESL's operations in terms of capabilities and capacities by establishing a plan for infrastructure replacement and resource utilization.</p> <p>Supporting R&D Need: T.4.R2</p>	
Key Outputs	Expected Completion Date
Action plan for the replacement of analytical and ancillary equipment with strategy for fund mobilization.	December 2021

SGAS-003: Analysis Support and NWAL Coordination

Expected outcome #1	
Broader capabilities and increased capacity of the IAEA Network of Analytical Laboratories (NWAL) for timely, high quality analysis of safeguards samples.	
Supporting Priority Objective: T.2	
Key Outputs	Expected Completion Date
Qualification of one or more additional NWAL member for the analysis of safeguards samples.	December 2021

Expected outcome #2	
Strengthened quality assurance of IAEA Network of Analytical Laboratories (NWAL) analytical services.	
Supporting R&D Needs: T.2.R2, T.2.R3 and T.2.R4	
Key Outputs	Expected Completion Date
Qualification of one additional NWAL member for the provision of reference materials.	March 2020
Organization of one to two inter-laboratory comparison exercises per year.	December 2021

Expected outcome #3	
Enhanced operational efficiency of safeguards analytical services through maintained and upgraded Safeguards Analytical Laboratory Information Management System (SALIMS).	
Supporting Priority Objective: T.2	
Key Outputs	Expected Completion Date
Re-engineering of Mass Spectrometry Data Evaluation System (MSDES).	August 2020
Re-engineering of the NWAL Coordination application (Phase 1, core functionalities deployed).	December 2021

Expected outcome #4	
Increased capacity for the safe and secure shipment of nuclear material samples and analytical residues.	
Supporting Priority Objective: T.2	
Key Outputs	Expected Completion Date
Provision of Type B Shipping Containers for shipment of large U and Pu samples.	December 2021

SGCP-003: Safeguards Approaches

Expected outcome #1		
Improved ability to fully implement the State Level Concept through the development of internal guidance documents and additional tools for the development of State Level Approaches. Supporting R&D Need: V.2.R1		
Key Outputs	Expected Date	Completion
Methodology and guidance for assessing acquisition path steps, including a State's technical capability to develop nuclear fuel cycle technologies and facilities as well as nuclear material diversion and facility misuse scenarios.	December 2022	
MSSP consultancy meetings on guidance for assessing steps involving undeclared facilities during acquisition path analysis:	December 2020	
Reprocessing and hot cell technologies.	March 2020	
Reactor technologies (graphite/heavy water/light water moderated reactor types).	June 2020	
Fuel fabrication technologies.	September 2020	
Conversion technologies (HEU & Pu metal).	December 2020	
Completion of detailed technical guidance reports for assessing steps involving undeclared facilities during acquisition path analysis: To be determined on the basis of experiences gained in 2020. The consultancy meetings for the remaining NFC steps (sub-tasks) will continue in 20121.	December 2021	

Expected outcome #2		
Increased ability to detect undeclared nuclear material and activities through update and improvement of the 'Physical Model'. Supporting R&D Need: P.3.R1		
Key Outputs	Completion Date	
Updated Physical Model (all volumes)	June 2021	
Volume 1 (Mining and ore processing)	June 2020	
Volume 2 (Conversion)	March 2020	
Volume 3 (Uranium enrichment)	September 2020	
Volume 5 (Fuel fabrication)	September 2020	
Volume 6 (Reactor and neutron sources)	December 2020	
Volume 7 (Heavy water)	September 2020	
Volume 8 (Reprocessing and recycling of spent fuel)	March 2021	
Volume 9 (Spent fuel management)	March 2020	
Volume 10 (Radioactive waste)	September 2020	
Volume 11 (Hot cells)	September 2020	

Expected outcome #3		
Enhanced ability to safeguard new types of facilities through development of safeguards concepts and approaches for pyro-processing plants and small modular and/or Gen IV reactors. Supporting R&D Needs: P.5.R2 and S.3.R1		
Key Outputs	Expected Completion Date	
Model safeguards approaches for new types of facilities.	December 2021	

Model safeguards approach for a pyroprocessing plant.	December 2020
Model safeguards approach for a transportable (floating) nuclear power plant (KLT-40S).	September 2021
Model safeguards approach for a pebble-bed modular reactor (HTR-PM).	December 2021
Model safeguards approach for a passive small modular pressurized light water reactor (SMART: System-integrated modular advanced reactor).	December 2021
Model safeguards approaches for new types of small modular reactors to be determined by States.	December 2021

Expected outcome #4

Improved ability to verify facilities under the decommissioning phase through the development of safeguards implementation guidelines and concepts.

Supporting R&D Need: P.5.R1

Key Outputs	Expected Completion Date
Updated DIQ templates and safeguards guidelines to incorporate post-operation information at facilities under decommissioning.	December 2021
Updated DIQ templates for all types of facilities to incorporate post-operation information at facilities under decommissioning.	March 2020
DIQ completion guidelines and DIQ examples.	June 2020
Safeguards guidelines for facilities under decommissioning.	September 2020
Safeguards guidelines for post-accident facilities.	June 2021

SGCP-004: Strategic Planning and Partnerships

Expected outcome #1

Support to MSSP coordination and effective administration to address the R&D needs of the Department.

Supporting Priority Objectives: S.4 and C.3

Key Outputs	Expected Completion Date
SPRICS-hosted database of R&D needs and progress, to enable the system with visualizing capabilities of how R&D needs are being met by MSSP tasks.	December 2020
Ability for SPRICS users to view status report and action history for the previous 2 years (as a first step) of active tasks on task summary pages (with an intention to add more historical data in future biennium plans).	December 2020
SPRICS-generated agendas, meeting packages and summaries of decisions and agreed actions of annual and bi-annual review meetings with MSSPs.	December 2021

Expected outcome #2

Improved organizational ability to monitor, identify and adjust to changes in the operating environment in a timely manner.

Supporting Priority Objective: T.5

Supporting R&D Needs: P.3.R1

Key Outputs

Expected Completion Date

2020 Emerging Technologies Workshop.

January 2020

2020 Emerging Technologies Workshop Report.

May 2020

Explore feasibility of adapting existing Artificial Intelligence (AI)-based or automation-based capabilities to support continuous environmental scanning of the Department's operating environment.

December 2021

Expected outcome #3

Support to the Department's ability to fulfill its mission is augmented through vetted non-traditional partnerships.

Supporting Priority Objectives: S.1 and S.4

Key Outputs

Expected Completion Date

Development of a strategy for enhancing non-traditional partnerships.

December 2020

Development of a non-traditional partnerships coordination programme that facilitates contributions from vetted non-traditional partners.

December 2021

Development of partnerships with other IAEA Departments.

December 2021

Expected outcome #4

Strategic management processes are sustainable and integrated into the Department's management systems and enable enhanced management capabilities to predict, manage, communicate, prioritize and align resources to execute Departmental strategic objectives and priorities.

Supporting R&D Needs: C.1.R1

Key Outputs

Expected Completion Date

Strategy Execution Application (SEA) on the Strategy Portal with integrated KPIs exists.

December 2021

Living Strategic Plan management facilitated by Strategy Portal.

December 2021

A biennial strategy implementation plan is published and in use.

December 2020

SGCP-101: Quality Management

Expected outcome #1

Enhanced integration of quality management principles into the implementation of safeguards activities.

Supporting R&D Needs: W.1.R1 and P.1.R2

Key Outputs

Expected Completion Date

A QMS training curriculum to be followed by focused instructor-led training as part of the CTR training catalogue.

December 2021

A more formal and rigorous means for identification, management and mitigation of risk, as part of the Department's QMS.

March 2020

Expected outcome #2

Improved process governance and an enhanced process framework, to support consistent implementation of departmental processes.

Supporting Priority Objective: V.3

Key Outputs**Expected Completion Date**

Integration and use of Business Process Model and Notation (BPMN). December 2020

A documented business process maturity model baseline. June 2020

A roadmap for improving business process maturity in the Department. December 2020

Expected outcome #3

Effective quality management activities are enabled in the Department, through robust IT software, tools and applications.

Supporting Priority Objective: T.3

Key Outputs**Expected Completion Date**

Implementation of an upgraded document manager software application and interface. December 2021

Implementation of an enhanced software application for condition reporting. December 2021

A process performance dashboard, which can be used by process owners and CPD to monitor and improve the effectiveness of processes in the Department (this effort is complementary to an existing prototype, which has been developed internally). December 2020

Expected outcome #4

A more robust knowledge management programme, which closes gaps identified in a recent self-assessment against the ISO 30401 standard for knowledge management.

Supporting Priority Objective: W.3

Key Outputs**Expected Completion Date**

A process for optimizing knowledge development and sharing, as part of the Department's induction process. March 2021

Promotional activities accompanied by educational material to further support the awareness of and commitment and support to the knowledge management programme. December 2021

Expected outcome #5

Enhanced financial transparency and accountability for safeguards implementation, through the continued development and refinement of the cost calculation methodology.

Supporting Priority Objective: S.1

Key Outputs**Expected Completion Date**

Enhanced capabilities for modeling and estimating costs associated with safeguards activities. September 2020

SGCP-102: Training

Expected outcome #1	
<p>Competent and confident departmental staff members (including support staff, analysts, inspectors and managers) who have the knowledge and skills to conduct safeguards verification activities at headquarters and in the field and have the analytical, technical, communication and leadership skills to implement safeguards.</p> <p>Supporting R&D Need: W.1.R1</p>	
Key Outputs	Expected Completion Date
Training in fundamental safeguards competencies and associated safeguards processes (skills associated with safeguards measures and activities, such as nuclear material accountancy, non-destructive assay, design information verifications, etc.).	December 2021
Initial training offerings for new, emerging and/or unexpected NFC and safeguards technologies (for example, Design Information Verification (DIV) training in SMRs or facilities undergoing decommissioning).	December 2020
Development of a comprehensive industrial safety curriculum/programme for inspectors.	June 2021
Training in the State Evaluation process and associated skills.	September 2021
Expected outcome #2	
<p>Competent and confident departmental staff members within the organizations of an SSAC, with the knowledge and skills to effectively implement safeguards and fulfill safeguards obligations.</p> <p>Supporting R&D Need: W.1.R1</p>	
Key Outputs	Expected Completion Date
An implemented training programme for Member States that addresses international, regional and national requests and needs as identified through State evaluations and operational requirements.	December 2021
Updated ISSAS guidelines and outreach campaign to States, to increase awareness of ISSAS missions.	June 2021
Development of State SSAC self-assessment guide (for example, a 10-point review guide).	December 2021
Development of two or three e-learning modules for States with a Comprehensive Safeguards Agreement (CSA) on State obligations and NMA for Small Quantity Protocol (SQP) States.	November 2021
Expected outcome #3	
<p>Bolstered awareness/interest/passion/knowledge of importance of safeguards in the international community (for example, university professors teaching law or Nuclear Engineering, Member States with safeguards agreements, "next generation" university students).</p> <p>Supporting Priority Objective: W.4</p>	
Key Outputs	Expected Completion Date
Gap analysis of outreach materials (inventory of existing material and identified priority materials requiring development).	June 2020
Development of sample curriculum of IAEA SG basics.	June 2020
Packaged assortment of SG materials (such as a starter kit in SG knowledge, including recommended reading for educational purposes).	September 2020

Expected outcome #4

Increased quality and accessibility of training and learning through modernization of facilities in and modes of course offerings.

Supporting R&D Need: T.4.R1

Key Outputs

Expected Completion Date

"Train-the-Trainer" courses available to CTR staff for training in best practices.	June 2021
Inventory of all courses and assessment of which courses are suitable for e-learning or an e-learning component.	June 2020
E-learning modules and blended courses available for internal and external staff.	December 2021
A training material database.	December 2021

Expected outcome #5

Increased knowledge of safeguards and aspects of the nuclear fuel cycle in Member States with limited or no nuclear fuel cycle technologies.

Supporting R&D Need: S.3.R1

Key Outputs

Expected Completion Date

Yearly implementation of the Safeguards Traineeship Programme.	December 2021
--	---------------

SGIM-002: Satellite Imagery Analysis

Expected outcome #1

Enhanced analytical capability through evaluation and use of new satellite sensors, imaging capabilities, software tools, analytical/processing techniques and provision of expert personnel.

Supporting R&D Needs: T.3.R3, V.1.R1 and V.4.R1

Key Outputs

Expected Completion Date

Incorporation of new multi-sensor satellite imagery analysis (SAR, SWIR, hyperspectral) into imagery analytical products.	December 2021
Diversify commercial sources of satellite imagery to ensure the integrity and authenticity of satellite imagery as an independent source of information for the Agency.	December 2021
Enhance satellite imagery acquisition and analysis through the exploitation of satellite vendor streaming services.	December 2021
Provision of personnel with a strong technical background in satellite imagery analysis, geospatial analysis or image processing.	December 2021

Expected outcome #2

Enhanced staff skills in processing and analysing satellite imagery, improved analysis of nuclear fuel cycle imagery signatures and increased awareness of satellite imagery analysis throughout the Department.

Supporting R&D Need: W.1.R1

Key Outputs

Expected Completion Date

Attendance at satellite imagery and geospatial international conferences (GEOINT and Esri).	December 2021
Onsite familiarization visits to nuclear fuel cycle sites.	December 2021
Satellite imagery and geospatial training courses and workshops.	December 2021

Expected outcome #3

Enhanced collaborative analysis through enabling the analysis of safeguards-relevant information from other relevant applications (for example, Additional Protocol System (APS) and Safeguards Master Data) and exposing geospatial information to other applications in Integrated Safeguards Environment (ISE) (for example, Collaborative Analysis Platform (CAP) and Geo-Based Data Integration (GDI)).

Supporting R&D Need: V.1.R3

Key Outputs

Expected Completion Date

Enhance processes and workflows for the collection and dissemination of satellite imagery and geospatial data. December 2021

SGIM-003: Information Analysis

Expected outcome #1

Enhanced assessment of nuclear programmes and detection of inconsistencies in States' declarations through the development of optimized tools and methods for the collection, processing and management of currently utilized safeguards-relevant open source information.

Supporting R&D Need: V.1.R1

Key Outputs

Expected Completion Date

A developed capability within the current automatic collection system, OSIS, to provide autonomous browsing of the Internet to identify and return safeguards-relevant information. December 2020

An enhancement to the automatic collection, processing and management of safeguards-relevant open source information, including mechanisms for adding structure to unstructured data. December 2021

A review and optimization of current open source information search and collection methodologies and techniques. December 2021

Expected outcome #2

Enhanced assessment of nuclear programmes and detection of inconsistencies in States' declarations through the development of optimised tools and processes to update and diversify the pool of safeguards-relevant open source information.

Supporting R&D Need: V.1.R2

Key Outputs

Expected Completion Date

Deployed tools, methods and procedures for the optimised use of multimedia information analysis under the SG-Multimedia Project. December 2020

Develop and implement a modern software package to facilitate the assessment of potential safeguards-relevant activities and procurements associated with the provision of Agency technical assistance. July 2020

Enhancement of tools and methods to optimise the continuous monitoring of new sources of information. December 2021

Expected outcome #3

Improved State evaluation process through continuously improved open source information analysis methods and computerized tools to aid the analysis of large amounts of structured, semi-structured and unstructured data.

Supporting R&D Need: V.5.R3

Key Outputs

Expected Completion Date

Deployed tools such as the Big Table, developed in conjunction with JRC, to enhance the analysis of safeguards-relevant information on trade and industrial capabilities of States, including through the use of data visualization.	December 2020
Utilization of data visualization and network analysis on structured and semi-structured open source information (including trade data).	July 2020
Development, deployment and enhancement of any additional tools, following above strategy.	Ongoing
Training for trade and technology analysis teams.	At least one per year

Expected outcome #4

Improved integration of open source information in 'all source' information analysis, contributing towards collaborative analysis.

Supporting R&D Need: V.1.R3

Key Outputs

Expected Completion Date

Integration of open source information collections with Integrated Safeguards Environment (ISE) State Files, commercial link analysis software and other applications.	July 2021
Integrate a commercial reference manager with commercial link analysis software to facilitate structuring of science and technology information.	July 2021

SGIM-007: Evaluation of Data from ES and Material Characterisation

Expected outcome #1

Improved understanding of elemental and isotopic signatures of NFC activities and processes (for example, uranium conversion, reprocessing and laser enrichment).

Expanded understanding of detectable signatures of NFC activities (isotopic, elemental and morphological characteristics of key materials), including the formation, transport and transformation of particles in the environment and improved methods for the collection of such material through ES.

Supporting R&D Need: V.5.R2

Key Outputs

Expected Completion Date

Collection of uranium impurity data and fuel burn-up inventories obtained from studies completed by Member States for integration into existing SGIM-IFC evaluation libraries.	December 2021
Development of beta software for aLChEMy, evaluation software for cross referencing isotopic and elemental data with NFC (Physical Model) signatures.	December 2021
Initiated studies for developing alternate sampling methods and media for more effective particulate collection.	December 2020

Expected outcome #2

Optimized evaluation of ES results and improved safeguards verification.

Supporting R&D Need: V.5.R1

Key Outputs

Expected Completion Date

Statistical approaches to evaluate particle data from enrichment facilities have been explored. December 2021

Visual Sampling Plan software for providing detection/non-detection confidence levels of ES results has been assessed. December 2020

Expected outcome #3

Continuity of knowledge and best practices in data evaluation is maintained.

Supporting R&D Need: T.3.R4

Key Outputs

Expected Completion Date

ESDB is migrated to Oracle 12c. December 2020

ESDB accepts measurement data associated with age-dating of uranium particles. December 2020

Best practices for ES evaluations are documented. December 2021

SGIM-008: Statistical Analysis

Expected outcome #1

Standardized methodologies in support of State Level Approaches for calculating detection probabilities achieved through verification activities at facility and State levels, with the aim of supporting the determination of frequencies and intensities of quantitative verification activities and of evaluating the effectiveness thereof.

Supporting R&D Need: V.5.R1

Key Outputs

Expected Completion Date

Finalized development and technical documentation on methodology to calculate detection probability achieved through verification measurements at facility level. December 2020

Development and technical documentation on expanding detection probabilities from facility to State level. December 2021

Technical documentation on randomized inspection schemes to address quantifiable misuse scenarios and associated prototype software to calculate frequencies and achieved detection probabilities. December 2020

Expected outcome #2

Improved and harmonized random inspection schemes (including short notice random inspections (SNRIs)) and methodologies developed to evaluate their effectiveness.

Supporting R&D Needs: V.5.R1 and V.5.R3

Key Outputs

Expected Completion Date

Development and documentation of a set of standard random inspection schemes, including standard evaluation methodologies, as a basis for a more harmonized approach to implementing and evaluating such schemes in verification activities. December 2021

Expected outcome #3

Further developed sampling methodologies described in STR-381 and practical implementation procedures for these methodologies.

Supporting R&D Need: V.5.R1

Key Outputs**Expected Completion Date**

Produce prototype software implementing basic safeguards sampling procedures described in STR-381. June 2020

Produce documentation of practical implementation procedures, for inclusion in the Inspector Handbook. December 2020

Expected outcome #4

Reviewed, updated and consolidated algorithms for the determination of measurement error uncertainties from operator-inspector paired-data, 3-laboratory data and calibration data.

Supporting R&D Need: V.5.R3 and T.3.R2

Key Outputs**Expected Completion Date**

Publication of peer-reviewed STR on Uncertainty Quantification. December 2021

Documentation of UQ algorithms employed for Verification Measurement Performance Evaluation in STEPS. December 2020

Expected outcome #5

Reviewed, updated and consolidated methodologies applied to the evaluation of material unaccounted for (MUF), D, IMUF and SRD in the context of material balance evaluation.

Supporting R&D Need: V.5.R3 and T.3.R2

Key Outputs**Expected Completion Date**

Technical documentation of statistical algorithms implemented in STEPS MBE module for statistical evaluations of MUF, D, IMUF and SRD. December 2020

Expected outcome #6

Methodologies reviewed, requirements documented and developed for a harmonized NRTA system for future implementation in, inter alia, the Rokkasho Reprocessing Plant (RRP) and J-MOX facilities.

Supporting R&D Need: V.5.R3

Key Outputs**Expected Completion Date**

Produce comprehensive NRTA methodology documentation in the form of a STR. December 2020

Produce requirements documentation for harmonized NRTA software system, for use as a standardized platform for NRTA evaluation systems at RRP and JMOX. December 2021

Expected outcome #7

Enhanced data visualization software for nuclear material flow analysis and additional capabilities of the software to represent acquisition path analysis results, verification requirements and achieved verification results, using structured nuclear material accountancy and verification data (in collaboration with SGIS-003).

Supporting R&D Need: V.4.R1

Key Outputs

Expected Completion Date

Migration of SNAKEY nuclear material flow visualization software into ISE (as a component of STEPS) and implementation of access management system to SNAKEY to allow appropriate operations division access.

December 2020

Implement enhancements to include verification requirements and achieved verification results in nuclear material data visualization.

December 2021

Expected outcome #8

Developed Bayesian approaches making use of historical verification data in the evaluation of safeguards information.

Supporting R&D Need: V.5.R1

Key Outputs

Expected Completion Date

Issuance of peer-reviewed technical documentation on Approximate Bayesian Computation for UQ.

December 2020

Incorporation of appropriate methodology from technical documentation into statistical evaluation software for UQ.

December 2021

Expected outcome #9

Investigate accountancy and measurement requirements and gather experience with factors affecting material balance evaluation at pyro-processing facilities (see also SGCP-003).

Supporting R&D Need: V.5.R3

Key Outputs

Expected Completion Date

Model material balance approach for a pyro-processing facility using results from the USA/ROK Joint Fuel Cycle Study.

December 2020

SGIM-009: State Declared Information Management

Expected outcome #1

More efficient information exchange, saving time and effort through State Declarations Portal enhancements.

Supporting R&D Need: T.3.R1

Key Outputs

Expected Completion Date

NMA Reports may be validated by the Member State users so that corrective action can be taken. Validation will include the full Quality Control (QC) against historical data. Validation results, as reports, will be returned to the Member State.

December 2021

A test country mock-up exists for training and demonstration purposes.

December 2021

Improved or new internal workflows, to increase efficiency of information flows between SGIM/ISD and Operations divisions.

December 2021

The graphical user interface (GUI) is translated into five additional languages (Chinese, French, Russian, Spanish and Arabic).

December 2021

Training materials are translated into five additional languages (Chinese, French, Russian, Spanish and Arabic). December 2021

Promotional material—in English, Chinese, French, Russian, Spanish and Arabic—is available to communicate system advantages and address user concerns regarding transmission security and/or infrastructure constraints within a Member State’s decision-making authorities. Possible translations into other languages, for Member States whose adoption of the SDP would generate a high added value. December 2021

Expected outcome #2

Reduced cost of, and improved access to, e-learning lessons to support SRA training (in collaboration with SGCP-102).

Supporting R&D Needs: S.2.R1 and T.5.R5

Key Outputs

Expected Completion Date

A new web portal, hosted by the IAEA’s learning management system, is established. December 2020

Ten 2- to 5-minute-long State declaration process e-learning modules that allow SRAs to collect and recall course material more efficiently and effectively. December 2020

Expected outcome #3

More efficient creation of accountancy reports, additional protocol (AP) declarations and State-declared information, integrated with other safeguards-relevant information through software tools used by SRAs.

Supporting R&D Need: T.3.R5

Key Outputs

Expected Completion Date

A developed software, “Reports Creation Tool” (RCT), for use by SRAs in creating and submitting accountancy reports. December 2021

Stand-alone software “Quality Control Verification Software” (QCVS) for validating nuclear material accountancy reports will be maintained. December 2021

Updated “Protocol Reporter 3” (PR3) software for users is widely deployed to States. December 2021

Expected outcome #4

A system to enable the processing of Requests for Exemption, Terminations and Re-applications. The system will allow checking between State reports and records of exemptions and terminations of nuclear material with the nuclear material accounting database.

Supporting R&D Need: V.1.R1

Key Outputs

Expected Completion Date

An implemented workflow for Exemption, Termination and Re-application requests of nuclear material. This will integrate with the nuclear material accounting system, to enable checking of State reporting. December 2021

Deployed quality control tool linking the decision-making process to the processing and evaluation of related inventory change reports. December 2021

Expected outcome #5

Upgraded Safeguards Master Data (SGMD) application.

Supporting R&D Need: V.1.R1

Key Outputs**Expected Completion Date**

SRA address integration in SGMD.

December 2021

Deployment of related SGMD reports.

December 2021

SGIS-002: Information Security and Infrastructure**Expected outcome #1**

Sufficient security knowledge is reflected in policies, procedures, governance and staff culture.

Supporting R&D Needs: W.1.R1, P.1.R1 and P.1.R.2

Key Outputs**Expected Completion Date**

The Safeguards Information Security Management System's (ISMS) policies, procedures and governance will meet the requirements of the Division of Nuclear Safety and Security (NSNS) as well as the Department's, and are based on International Organization for Standardization (ISO) standards.

December 2020

A measurable and coordinated information security management programme is in place.

December 2020

Security awareness training and testing is in place.

December 2021

Training is available for departmental staff members in new technologies, security metrics, security incident response, digital forensics, specific security products and secure software and systems development processes.

December 2021

Expected outcome #2

Strengthened access control solutions.

Supporting R&D Need: P.1.R2

Key Outputs**Expected Completion Date**

Enhanced and integrated Authorization Management System, including extending the centralized authorization system to unstructured data stores and resources which are currently managed through other means.

Continuous

Access control solutions are in place that eliminate the risk of unauthorized access to systems and services.

Continuous

Expected outcome #3

Increased trust in the Department's information and systems through enhanced cryptography and secure communication solutions.

Supporting R&D Need: P.1.R2

Key Outputs**Expected Completion Date**

Developed and deployed software is authenticated and trusted. Software developed by the Department will be digitally verifiable as authentic.

May 2020

Ability to securely transfer between internal and external parties safeguards-relevant data, additional to that already accommodated within secure declarations, in accordance with agreed safeguards processes (for example, to securely share relevant information for projects, subject to statutory limitations).

September 2020

Enhanced key management standards and solutions.	May 2021
Secure email for mobile devices.	December 2020
End-to-end secured solutions for communication.	December 2021

Expected outcome #4

Enhanced security controls on operational systems and solutions.

Supporting R&D Needs: P.1.R1 and P.1.R2

Key Outputs	Expected Completion Date
Improved secure development lifecycle for SG products.	December 2021
Improved insider and external threat detection and "threat hunting" capabilities.	December 2021
Security assessments and improved incident management solutions.	December 2021

Expected outcome #5

Increased trust in the Department through enhanced physical security and environmental solutions.

Supporting R&D Needs: P.1.R1 and P.1.R2

Key Outputs	Expected Completion Date
Enhancements to the physical security system.	March 2020
Enhancements to the physical access control mechanisms.	June 2021
Development of potential next generation physical security systems.	June 2020

Expected outcome #6

Increased ability to remain operational after an adverse event through BC/DR capabilities including planning, equipment, IT solutions, facilities and regular exercises.

Supporting R&D Need: P.2.R1

Key Outputs	Expected Completion Date
Plans, policies and procedures for continuity and recovery events.	December 2020
Arrangements for ensuring availability of critical equipment in the event of disruption, including detailed business continuity plans.	December 2020
Identification and availability of alternate facilities.	May 2021
Enhanced IT Disaster Recovery (DR) capabilities.	December 2021
Exercised and maintained BC/DR programme.	December 2021
Training for departmental staff members.	December 2021

SGIS-003: Safeguards Information Systems and System Usability

Expected outcome #1	
Improved Safeguards IT Products supporting IAEA Safeguards business more effectively and efficiently.	
Supporting R&D Needs: T.3.R1, T.3.R2, T.3.R3, T.3.R5, T.4.R1, V.1.R1, V.1.R3, V.4.R1 and V.5.R3	
Key Outputs	Expected Completion Date
Improved Safeguards IT Products supporting analytical, services, State cooperation and verification processes to enhance the user-experience and system performance with an increased number of IT features and business capabilities.	December 2021

Expected outcome #2	
Further optimization of departmental processes through the identification and development of new IT capabilities.	
Supporting R&D Needs: T.4.R1, V.4.R1, V.1.R3 and V.1.R1	
Key Outputs	Expected Completion Date
New IT products in line with Departmental strategic priorities to optimize processes and improve the delivery of IT services with capabilities for the storage, retrieval and analysis of SG data.	December 2021

SGOA-002: Safeguards System for JNFL MOX Fuel Fabrication Plant (J-MOX)

Expected outcome #1	
Developed effective and efficient safeguards approach and procedures for J-MOX.	
Supporting R&D Need: V.5	
Key Outputs	Expected Completion Date
Safeguards approach for J-MOX, based on the elements agreed with Japan.	Dependent upon construction decisions and commissioning schedule
DIE/DIV procedures that assure that the facility is constructed and will operate as declared, while ensuring that the safeguards approach remains adequate and robust.	Dependent upon construction decisions and commissioning schedule

Expected outcome #2	
Developed, tested and deployed verification systems at facilities to meet safeguards requirements.	
Supporting R&D Needs: T.1.R3, T.1.R5, T.5.R8 and V.5.R3	
Key Outputs	Expected Completion Date
Designed, tested and installed safeguards equipment (NDA, C/S) that provides high quality, independent and reliable results.	Dependent upon construction decisions and commissioning schedule
Designed, tested and implemented integrated data collection and evaluation software for J-MOX, using synergies with the RRP Information System.	Dependent upon construction decisions and commissioning schedule

SGOA-003: Fukushima Dai-ichi Safeguards

Expected outcome #1	
Ability to provide credible and reliable assurance that nuclear material is not removed from damaged facilities; by designing, developing and deploying monitoring systems using surveillance devices, radiation detectors or other methods, with specialized support and expertise on monitoring systems. (In close collaboration with SGTS-001 and SGTS-002).	
Supporting R&D Need: P.4.R2	
Key Outputs	Expected Completion Date
Improve the OASM review software.	December 2020
Install/replace surveillance devices.	Continually

Expected outcome #2	
Effective and efficient safeguards approaches are implemented for the Fukushima Dai-ichi site that include measures applicable to removed fuel-containing debris.	
Supporting R&D Need: P.4.R2	
Key Outputs	Expected Completion Date
A drafted Safeguards Approach, with specific implementation procedures applicable to the new facilities and material handling involving the removal of nuclear fuel bearing debris.	December 2020
A developed verification concept based on supporting facility preliminary design information and applicable to removed nuclear fuel bearing debris that may be containerized and processed through a hot cell.	December 2021

SGOC-001: Chornobyl

Expected outcome #1	
Safeguards are applied in an efficient and effective manner through finalized procedures for safeguards implementation at facilities under this project.	
Supporting R&D Need: P.4.R2	
Key Outputs	Expected Completion Date
Implemented mailbox system for ISF-2.	July 2020
Approved verification procedures for ISF-2.	July 2020
Approved verification procedures for NSC.	July 2021

Expected outcome #2	
Enhanced ability to carry out verification activities using equipment that is installed, adjusted and approved for verification use (in close collaboration with SGTS-014).	
Supporting R&D Need: P.4.R2	
Key Outputs	Expected Completion Date
Equipment at ISF-2 is tested.	July 2020
Installation of equipment at the NSC is complete.	July 2021
Equipment at NSC is tested, adjusted and approved.	July 2021

SGTS-001: NDA Techniques

Expected outcome #1	
Enhanced performance and usability of medium-resolution gamma spectrometry for nuclear material verification.	
Supporting R&D Need: T.5.R9	
Key Outputs	Expected Completion Date
Acquisition and performance evaluation of the ultra-large volume (up to 29 cm ³) Cadmium-zinc-telluride (CDZT) probe.	July 2020
Authorization of a large-volume segmented CDZT-based Compton and coded aperture gamma camera.	July 2020
Performance validation of the uranium enrichment determination codes for analysis of CDZT gamma spectra (NaIGEM, FRAM 6.0).	December 2020
Expected outcome #2	
Improved NDA methodologies for verification of uranium at bulk facilities.	
Supporting R&D Need: T.1.R5	
Key Outputs	Expected Completion Date
Determination of uranium concentration (up to 20 wt%) and enrichment of in-process material using high-resolution gamma spectrometry.	March 2021
Determination of uranium concentration in aqueous uranyl sulphate solutions using Raman spectrometry.	December 2021
Assessment of capabilities of portable LIBS for impurity content determination in uranium-bearing materials.	December 2021
Expected outcome #3	
Improved instruments and techniques to address verification of waste and scrap nuclear material with impure composition or heterogeneous isotopic composition.	
Supporting R&D Need: T.1.R6	
Key Outputs	Expected Completion Date
Development of new data processing algorithm.	March 2020
Performance evaluation and authorization of CTGS.	July 2020
Expected outcome #4	
Development and testing of new PGET capabilities.	
Supporting R&D Need: T.1.R6	
Key Outputs	Expected Completion Date
Development, testing and implementation of the algorithms and software modules required for the remote and unattended operation of PGET.	December 2020
PGET performance evaluation on VVER-1000.	November 2020

Expected outcome #5

Capability to restore Continuity of Knowledge (CoK) on light water reactor spent fuel casks by fast neutron scanning & imaging techniques.

Supporting R&D Need: T.5.R8

Key Outputs**Expected Completion Date**

Confirmation of feasibility by simulation studies (including validation of the numerical model) and experimental proof-of-principle demonstration (Decision point 1).

December 2020

Development of the user requirements; design and manufacturing of a prototype system.

December 2021

Field-testing (Decision point 2) and authorization for nuclear material verification, which is dependent on a successful performance evaluation.

December 2022

SGTS-002: Techniques and Instruments for Sealing and Containment Verification**Expected outcome #1**

Reduced inspector burden by demonstrating efficacy of LCCT.

Supporting R&D Need: T.5.R10

Key Outputs**Expected Completion Date**

Pre-Installation joint-evaluation of completed SG-authorized system and its data with ABACC/ARN at non-critical facility in Argentina.

January 2020

An installation and field test of an LCCT at the dry storage silo array in Atucha-1, to demonstrate efficacy of wide area dual C/S for silos.

July 2020

Joint-evaluation system in Germany storage facility to determine effectiveness in decreasing effort.

February 2020

Broader authorization for other facilities.

July 2021

Expected outcome #2

Maintain safeguards verification through seals by replacing the aging EOSS.

Supporting R&D Need: T.5.R10

Key Outputs**Expected Completion Date**

Obtain approval for implementing field tests.

January 2020

Completed radiation tests on Active Universal Asymmetric Seal (AUAS). Completed environmental tests on AUAS.

May 2020

Commence vulnerability assessments.

June 2020

Initiate field tests at multiple locations.

July 2020

Analyse results from completed field tests and mitigate deficiencies.

July 2021

Authorize AUAS as a replacement for EOSS.

January 2021

Expected outcome #3

Effective, passive, verifiable-in-the-field seals that replace E-CAP (metal seals).

Supporting R&D Need: T.5.R10

Key Outputs**Expected Completion Date**

Finalized seal designs.	February 2020
Assessments of the designs, security features and vulnerabilities of the seals.	May 2020
Initial results from field-testing of the selected designs.	June 2020
Selection of the final seal design.	January 2021
Submission of the final seal design for Department authorization.	May 2021

Expected outcome #4

Decreased efforts during DIVs by more efficient continuity of knowledge (CoK) for destructive analysis (DA) samples. This approach allows for CoK inside hot cells but verifiable from outside the hot cell. The system supports objectives required for pyro-processing facilities in the ROK and elsewhere.

Supporting R&D Need: T.5.R10

Key Outputs**Expected Completion Date**

A finalized design of the Hot Cell Enclosure for Samples (HCES).	May 2020
Results from continued field tests to prove efficacy of the HCES.	June 2020
Iterated designs and prototypes of HCESs as required.	July 2020
A completed vulnerability review of the HCES.	January 2021
Initiation of the Safeguards Authorization process for the new HCES.	May 2021

Expected outcome #5

Mitigated safeguards vulnerabilities by exploration of alternative passive sealing technologies that enhance or replace current passive seals.

Supporting R&D Need: T.5.R10

Key Outputs**Expected Completion Date**

Assessment from reports and/or data on practical technologies emerging on the commercial market on high security Radio-Frequency Identification (RFIDs).	December 2021
--	---------------

Expected outcome #6

Improve the security of data collected on the computers of mobile safeguards equipment by developing and improving cryptographic techniques in coordination with Departmental security objectives.

Supporting R&D Need: T.5.R10

Key Outputs**Expected Completion Date**

A research paper on the latest relevant cryptographic techniques.	May 2020
Consult with Member State experts in cryptographic technologies.	December 2020
Expert consultations and sessions in cryptography to determine results and testing protocols (in other words, discuss testing researched work).	January 2021

Results from cryptography technique tests on safeguards equipment (in other words, assessing tests agreed in the Expert consultations. June 2021

Implementation of cryptography techniques based upon the conclusions from the tests. December 2021

SGTS-003: Surveillance Techniques

Expected outcome #1

Enhanced ability to deploy equipment at facilities, to meet safeguards requirements through development of highly effective and cost efficient optical surveillance measures with improved security features.

Supporting R&D Needs: T.1.1.R2 and T.5.R4

Key Outputs

Expected Completion Date

Working NGSr prototype for benchmark testing developed in collaboration with Project SGTS-014 (Assessment of Phase 1 NGSr surveillance review software). December 2020

Initial performance assessment report of the prototype shape recognition module using relevant datasets. March 2020

Assessment results report for the VideoZoom module. September 2020

Create, refine and document the initial user requirements to guide the development of surveillance technologies intended to succeed NGSS. December 2021

Expected outcome #2

Improved ability to detect undeclared activities at nuclear facilities with tools and techniques.

Supporting R&D Need: T.1.1.R3

Key Outputs

Expected Completion Date

Evaluation of advanced 3DLR and LiDAR technologies in relevant facilities in support of ongoing safeguards activities. December 2021

Evaluation of the potential of 3DLR and advanced LiDAR technologies to support unique implementations of Dual Containment and Surveillance (C/S). December 2021

Expected outcome #3

Improved real-time monitoring and flow measurement capabilities of nuclear material at nuclear facilities (for example, UF6 cylinders and spent fuel casks) by developing tools and techniques.

Supporting R&D Need: T.1.1.R5

Key Outputs

Expected Completion Date

A developed ultra-high frequency (UHF) Passive Tag monitoring and tracking system with advanced capabilities for persistent, real-time, non-optical surveillance of items of interest. July 2021

A developed conceptual framework for an Ultra-Wideband (UWB) Passive Tag monitoring and tracking system with advanced capabilities for persistent, real-time, non-optical surveillance of items of interest. December 2021

Expected outcome #4

Improved response to new threats resulting from technology advancements, through advanced intrusiveness and vulnerability analysis on current and future use of unattended systems.

Supporting R&D Need: T.1.R9

Key Outputs

Expected Completion Date

An evaluation and vulnerability assessment of the DCM-A1, next generation analogue camera recording module, with respect to tamper indication efficiency and effectiveness.

June 2020

SGTS-008: Instrumentation Technology Foresight

Expected outcome #1

Improved and more efficient safeguards verification activities in the field through the use of innovative technologies.

Supporting R&D Needs: T.5.R1 and T.5.R2

Key Outputs

Expected Completion Date

Progressive roll-out of XCVD for spent fuel verification and transfer to SGTS-001: NDA Techniques

December 2021

Deployable Robotized Cerenkov Viewing Device (RCVD) enclosed inside an Unmanned Surface Vehicle (USV).

December 2021

Inclusion of Chemical Identification spectrometers in the MCIK and expansion of their application in the field.

June 2021

Integration of Instrument Record Integrator for Safeguards (IRIS) within MOSAIC tools, for streamlined reporting of field instrument data.

December 2021

Completion of annual technology challenge for improving SG instrument data analysis.

June 2021

Expected outcome #2

Ability to develop, design and enhance safeguards solutions, faster and with fewer resources, by using external technologies from relevant R&D fields.

Supporting Priority Objective: T.5 and S.4

Key Outputs

Expected Completion Date

A list of new, external, non-traditional technology suppliers that have demonstrated their ability to develop specific solutions applicable to the domains of non-destructive assay, containment, surveillance and destructive analysis. (In collaboration with SGCP-004).

Ongoing

Searchable Technology Foresight Database summarizing the results of technology evaluation.

December 2021

Quarterly Technology Preliminary Evaluation Report.

Ongoing

SGTS-011: Unattended Measurements Techniques

Expected outcome #1	
Faster (and potentially real-time) detection of HEU production in LEU enrichment facilities through improved tools and techniques.	
Supporting R&D Need: T.1.R4	
Key Outputs	Expected Completion Date
Upgrades of On-Line Enrichment Monitor (OLEM) hardware and software.	December 2021
A report on overall OLEM performance enhancements.	July 2021
Expected outcome #2	
Ability to take real-time flow measurements of nuclear material, including UF ₆ at enrichment facilities and conversion plants and Pu at reprocessing facilities, through improved tools and techniques.	
Supporting R&D Need: T.1.R5	
Key Outputs	Expected Completion Date
Installation of UCVS at an IAEA-safeguarded Gas Centrifuge Enrichment Plant (GCEP) for field testing.	December 2021
Expected outcome #3	
Established and maintained knowledge of spent fuel in shielding/storing/transporting containers, at all points in their lifecycle, by developing safeguards equipment.	
Supporting R&D Need: T.1.R6	
Key Outputs	Expected Completion Date
Completion of the User (Operations) requirements of new instrumentation to detect and deter the misuse of nuclear material.	May 2020
Development of the instrumentation. The UGET system (Unattended Gamma Emission Tomography) being a potential candidate to address the need.	December 2021
Expected outcome #4	
Increased proportion of deployed unattended systems that are sustainable, standardized and modular, with increased use of Commercial-Off-The-Shelf (COTS) products.	
Supporting Priority Objectives: T.1 and T.4	
Key Outputs	Expected Completion Date
Evaluation of a TDR (Time Domain Reflectometry) prototype from the USSP.	End of 2020
Development and maintainability support of UMS electronic standard modules (ADM2- and LANL-based modules).	End of 2021

SGTS-014: Remote Data Transmission and Processing Systems

Expected outcome #1	
More efficient data review and verification by inspectors, through the development of CASCADE, adopting the current departmental software standards.	
Supporting R&D Needs: T.1.R1 and T.1.R5	
Key Outputs	Expected Completion Date
NRT Application for ISF2.	February 2020
Triggered data evaluation for IRAP-authorized facilities.	March 2020
Scheduled/on-demand data evaluation for IRAP-authorized facilities.	July 2020
SGLAN applications and NGSr integration into CASCADE.	January 2021
ISE applications integration into CASCADE.	June 2021
Remote system analysis capability for the Fork Detector (FDET).	September 2021
IRAP deployment and extension of CASCADE to other facilities.	December 2021

Expected outcome #2	
Improved VPN hardware for the RDT network.	
Supporting R&D Need: T.1.R9	
Key Outputs	Expected Completion Date
A tested and authorized Euratom-proposed VPN hardware for use in MSSP-provided test facilities in Germany.	June 2020
Implementation of a new VPN hardware, developed using pfSense (open source VPN secure firmware), with support for smartcard cryptography tokens.	December 2020

Expected outcome #3	
Improved efficiency of equipment maintenance, by upgrading ROOGLE.	
Supporting Priority Objective: T.1	
Key Outputs	Expected Completion Date
Integration of ROOGLE3 data with the Access Management System (AM).	January 2020
Integration of ROOGLE3 data with SMT and SEQUOIA.	June 2020
Hand carried data monitored by ROOGLE3.	December 2020
Integration of ROOGLE3 data with CASCADE.	June 2021
Move ROOGLE3 to the production environment.	January 2021

SGVI-001: JCPOA Verification

Expected outcome #1	
Continued development and deployment of training, tools and techniques specific to supporting the JCPOA.	
Supporting R&D Needs: V.1.R3 and W.1.R1	
Key Outputs	Expected Completion Date
Conduct training in Carbon Fibre Mechanical Testing for SGVI Inspectors.	December 2021

DDGO-001: Overall Safeguards Management and Coordination

Project Manager: Frédéric CLAUDE

1. Overview

This chapter describes the plans to strengthen executive-level management within the Department during the period 2020–2021.

Project objective

Project DDGO-001 is intended to facilitate improvements to (1) the lifecycle management and strategic recapitalization of critical safeguards assets; and (2) internal communications, through further implementation of the Department’s Strategic Internal Communication Plan.

The Department has made substantial capital investments in recent years—to both tangible and intangible assets—in support of its verification mission. These investments encompass different areas, including specialized equipment and infrastructure for destructive and non-destructive assay; a new generation of surveillance equipment; modern IT equipment; and specialized software. Such safeguards equipment, and other technologies critical for verification activities, vary widely in their lifespan, state of health, maintenance and replacement cost. In addition, some of the assets are located on IAEA premises, while others are hosted at facilities across the world.

The Department recognizes the importance of responsible and sustainable management of its assets, identifying “manage SG technology assets strategically” (T.4) as a priority objective for delivering its mission. This project, therefore, seeks to create a Department-level framework to ensure consistency for managing the lifecycle of all safeguards assets, including inspection equipment, analysis equipment, IT equipment and both specialized and COTS software. In order for the timely identification of recapitalization needs and to feed this information into the budget preparation process, the Department requires a mechanism to prioritize reinvestment requirements. A comprehensive integrated lifecycle management system will enable the Department to enhance its foresight of the funding needs required to maintain, replace and renew assets. Activities related to lifecycle asset management will be performed in close collaboration with all Divisions and Offices, primarily SGIS, SGTS and SGAS.

As the Department continues to face important challenges, especially associated with significant staff turnover, effective communication is essential. In order to facilitate valued, trusted and efficient internal communication that enhances teamwork and performance, the Department developed a Strategic Internal Communication Plan. This was designed to meet long-term communication goals, taking into account inputs from departmental staff members and management surveys, focus groups and interviews. The Plan was developed to enhance benefits and mitigate risks from communication within the Department. It aimed at nurturing a culture of collaboration, teamwork and information/knowledge sharing, as well as increasing staff trust in leadership and co-workers. While the Plan seeks to better utilize various communication tools and channels, significant attention is also given to building communication capacity within the Department. Work is continuing, to fully implement the Strategic Internal Communication Plan. Valuable contributions have been provided via the Member States Support Programmes, and these contributions continue to be of particular importance to the Project’s ability to address the Department’s communication goals.

Foreseen challenges

Sustained efforts will be required to resource the maintenance, replacement of ageing equipment and disposal of obsolete equipment.

Further, technological advancement must be fully considered, in order for this Project to meet its long-term objectives. This is especially the case in the field of communication, and continuous updates to the internal communication strategy will be essential to adapt to an ever-changing environment.

Another important element to be considered is staff turnover. This is not only a reason for, but also a challenge to, the sustained implementation of the Strategic Internal Communication Plan, which MSSPs are invited to support through MSSP task proposal 18/SPC-003 (Support for improved internal communication in Safeguards). Additional work will continue to be required, to maintain the Department’s communication capacity.

Top project priorities in 2020–2021

- Develop the Department’s capacity to strategically manage its assets (aligned with ISO 55000, ISO 50001, ISO 50002 and IPSAS) through new and updated guidelines, procedures, information system enhancements, inventory data cleansing, staff training and raising staff awareness.
- Increase the effectiveness of internal communication.

2. Strategy framework linkages

Safeguards Research & Development Plan linkage

Priority Objective		R&D Needs	
T.4	Manage Safeguards technology assets strategically	T.4.R1	Execute a long-term maintenance and replacement plan for the safeguards information technology system as a follow-up to MOSAIC.
		T.4.R2	Develop and execute a long-term replacement plan for analytical equipment at the Safeguards Analytical Laboratories, with an appropriate mix of regular and extra-budgetary funds.
S.1	Communicate proactively and transparently		
C.3	Strengthen departmental communication and coordination		
C.4	Secure and optimally manage financial resources		

Collaborating D&IS projects

- SGAS-002: Environmental Sample Analysis Techniques
- SGCP-004: Strategic Planning and Partnerships
- SGIS-003: Safeguards Information Systems and System Usability
- SGTS-003: Surveillance Techniques

3. Progress on expected outcomes, key outputs and tasks from the previous biennium

Expected Outcome #1 from the 2018–2019 Biennium		
Integrated asset management efforts at the departmental level for all Safeguards assets owned or operated by the Department.		
Supporting R&D Needs: T.4.R1 and T.4.R2		
Key Outputs	Status	Comments
Re-defined Safeguards procedures on asset management.	Delayed; work in progress	The current procedures were reviewed and work continues, to produce an integrated lifecycle safeguards asset management system.
Asset Management Plans (AMP) for key assets, as per ISO 55000-55002, for example, Safeguards Information Technology, Safeguards Inspection Equipment, and the equipment of the Safeguards Analytical Laboratory.	Delayed; work in progress	A preliminary study was completed. Preparatory work to update and improve the AMPs is in progress.

High-quality inventory data and information systems to enable data-driven analysis in support of the Department's recapitalization strategy.	Delayed; work in progress	Data clean-up in SEQUOIA and reconciliation with AIPS has started and will continue.
--	---------------------------	--

Expected Outcome #2 from the 2018–2019 Biennium

Enhanced foresight and decision support on funding needs and budgeting decisions for acquisition/replacement of Safeguards assets.

Supporting Priority Objectives: S.1 and C.4

Supporting R&D Needs: T.4.R1 and T.4.R2

Key Outputs	Status	Comments
A mechanism at the departmental level for funding renewals of critical Safeguards assets.	Delayed; work in progress	Key assets will be determined in the spring of 2020. The mechanism to replace the key assets will then commence.
Safeguards assets renewal long-term plan to communicate effectively with Safeguards stakeholders, including Member States, on potential extrabudgetary needs.	Delayed; work in progress	Preparatory work is underway, to define the long-term plan and substantiate funding requirements.

Expected Outcome #3 from the 2018–2019 Biennium

Effectively coordinated high-priority departmental capital investments and other tasks.

Supporting Priority Objectives: S.1 and C.3

Supporting R&D Needs: T.4.R1, T.4.R2 and T.5.R2

Key Outputs	Status	Comments
Development and/or acquisition of skilled resources with the necessary communications, technical, and managerial background for executive level coordination of high-priority initiatives on introducing new technologies and techniques, and to exploit innovations with impact on Safeguards implementation.	Key output achieved; work completed	The MOSAIC project was successfully coordinated by DDGO and completed in May 2018.

Expected Outcome #4 from the 2018–2019 Biennium

Increased capability for information sharing and greater collaboration.

Supporting Priority Objective: C.3

Key Outputs	Status	Comments
Implementation of a Department-specific internal communication strategy to enhance senior leadership and staff communication capabilities.	Key output achieved; work continues	Internal communication strategy was revised. Periodic updates are required.

Expected Outcome #5 from the 2018–2019 Biennium

Increased Staff engagement/satisfaction.

Supporting Priority Objectives: S.1 and C.3

Key Outputs	Status	Comments
Updated and implemented internal communication strategy, including review and updated use of the Safeguards Portal and new or improved communication channels for feedback, sharing, and relationship building.	Key output achieved; work continues	Internal communication strategy was revised. Periodic updates are required.
Continuous improvement in the consistency of internal messaging with messaging conveyed to Member States.	Key output achieved; work continues	A Departmental communication team has been established.

4. Expected outcomes, key outputs and tasks for the 2020–2021 biennium

In order to achieve overall objectives and meet R&D needs, tasks must be initiated, continued and/or finalized during the 2020–2021 biennium. The following expected outcomes serve as an outline for the next 2 years.

Expected outcome #1

Department-level strategy and tools for managing the lifecycle of SG assets based on prioritized needs and in alignment with the Agency rules and strategy.

Supporting R&D Needs: T.4.R1 and T.4.R2

Key Outputs	Expected Completion Date
Departmental strategic safeguards asset management plan with updated procedures, guidelines and policies.	May 2020
Asset Management Plans (AMP) for key assets, as per ISO 55000-55002.	May 2021
High-quality inventory data and information systems, to enable data-driven analysis in support of the Department's recapitalization strategy.	December 2020

Plans for accomplishing the expected outcome

The Department is drafting Asset Management Plans (AMPs) for safeguards information technology, safeguards inspection equipment and the equipment of the Safeguards Analytical Laboratory. These three asset management plans are expected to be completed in spring of 2020 and combined into one Departmental-wide AMP by May of 2020. Also in the spring of 2020, the Department will identify the 10-15 key assets and will create individual asset management plans for each. These individual AMPs, or "mini-AMPs," will be completed by May 2021.

Further, information systems are a pillar of effective asset management. The current safeguards inventory management software, SEQUOIA, has recently undergone re-development as part of the Modernization of Safeguards Information Technology (MOSAIC) project. This modernization has enhanced the capabilities of the legacy system EQUIS and improved integration with the Agency's enterprise resource planning system, AIPS. The Department conducted an initial analysis of the SEQUOIA data, from which a detailed plan to clean up the SEQUOIA data and reconcile it with AIPS has been developed. Based on this plan, and in collaboration with project SGIS-003: Safeguards Information Systems and System Usability, further work will be undertaken to establish the asset hierarchy, establish proper operational lifecycles, review consistency by family and conduct detailed analyses of different items.

MSSP tasks USA X 2468 (Safeguards Technical Specialist) and UK X 2475, NET X 2498 and USA X 2423 (Integrated Lifecycle Management of Safeguards Asset (ILSA)) support the implementation of the Project by providing a Cost-Free Expert and other consultants with expertise in asset management. Additional MSSP resources are requested to assist with expertise in organizational lifecycle asset management strategy or lifecycle management of specific technologies.

Expected outcome #2

Enhanced foresight and decision support on funding needs and budgeting decisions for replacement of safeguards assets.

Supporting Priority Objectives: S.1 and C.4

Supporting R&D Needs: T.4.R1 and T.4.R.2

Key Outputs

Expected Completion Date

Draft Departmental strategy for funding renewals of critical safeguards assets. May 2020

Long-term safeguards capital asset replacement plan to communicate effectively with safeguards stakeholders, including Member States, on potential extrabudgetary needs. May 2021

Plans for accomplishing the expected outcome

As the Department operates its critical assets, it faces the dual risk of asset deterioration and of not being able to maintain or replace these assets in a timely manner; in particular due to budget constraints. Under existing financial constraints, and with safeguards assets depreciating, the Department needs to further improve lifecycle management of safeguards technical capabilities and cover recapitalization needs in the medium- and long-term. Work is required to clearly prioritize capital investments in terms of risk and criticality, to collect necessary data through various safeguards information systems and identify realistic lifetimes for assets, to consider options to maximize asset lifetime and to understand the associated procurement cycles. This information will allow the Department to produce a long-term capital investment plan for the Department.

While capital renewal focuses mainly on the planned replacement of safeguards assets, in order to avoid the failure of critical assets, the scale and priorities for renewing assets in future years must also be estimated. The recapitalization budget is determined by projecting over a period of several years the forecasted expenditure to replace current safeguards assets at the end of their expected lifespan. One of the objectives of the Project is to enhance the existing recapitalization approach, to be supported by a revised financial strategy and mechanism in line with the Agency's rules and policies.

The improved decision support tools described in Expected Outcome #1 will enable the Department and the Agency to better understand the risks and costs associated with the intense operation of safeguards assets, required to meet the growing workload under statutory obligations. Efforts, therefore, will be aimed at improving the existing systems and creating a long-term financial plan for asset maintenance and recapitalization.

Expected outcome #3

Increased capability for information sharing and greater collaboration.

Supporting Priority Objective: C.3

Key Outputs

Expected Completion Date

Implementation of a Department-specific internal communication strategy to enhance senior leadership and departmental staff member communication capabilities. December 2021

Updated and implemented internal communication strategy, including review and updated use of Safeguards Portal and new or improved communication channels for feedback, sharing and relationship building. Continuous

Initiation of communication capacity-building training for departmental staff members. December 2021

Coordinated development of published communication to ensure consistency of messages conveyed to departmental staff members and to Member States. Continuous

Plans for accomplishing the expected outcome

Communication capacity in technical organizations requires strengthening connections and coordination between systems, processes and organizations. This requires ongoing learning, training and mentoring to account for environmental shifts and new technologies.

The Strategic Internal Communication Plan identifies 4 pillars to the Department's efforts to enhance internal communication:

- the strategic use of internal communication tools, events and channels
- facilitation of vertical and horizontal communication through meetings and reports
- communication capacity building
- the establishment of feedback and survey mechanisms

Progress has been made to address each of the pillars, but continued efforts are required to ensure the steady implementation of the Plan. Communication tools such as newsletters and graphic information sheets are more actively used in the Department, while the recently updated internal SG Portal provides a useful platform for information sharing. Furthermore, a Departmental communication working group was launched, and it convenes on a regular basis to promote further coordination and collaboration across Divisions. Additional emphasis has also been placed on the frequency and prominence of meetings, including those of the Deputy Director Generals, departmental, directors, divisions, SCM and section meetings, through which to ensure effective information/knowledge sharing at appropriate levels. In addition to these ongoing efforts, capacity building programmes are needed on such topics as strategic communication, risk mitigation and crisis communication, communication working group skills, mentoring and improving accountability.

In-house expertise would support the implementation of these activities based on the Strategic Internal Communication Plan. Further support will be welcome. Additional MSSP resources, including funding for consulting and design expertise would support the development of tools and materials as well as provide advisory support regarding other internal communication challenges.

Expected outcome #4	
Increased departmental staff member engagement and satisfaction.	
Supporting Priority Objective: S.1 and C.3	
Key Outputs	Expected Completion Date
Results of spot/pulse surveys and communication surveys.	December 2021
Facilitation of departmental staff member focus groups regarding communication.	December 2021

Plans for accomplishing the expected outcome

Improved internal communication not only promotes appropriate information sharing and coordination beyond Divisions and Sections, but also supports increased engagement of departmental staff members in their respective work. With wider opportunities for effective communication, departmental staff members can more readily share and collaboratively develop solutions in support of verification activities, while also finding efficiencies and reducing duplication of work. Particular emphasis should be placed on internal and external reporting, as the continuous streamlining of reporting work will further enhance the quality and consistency of the Department's information products. With an increased level of internal communication and coordination, departmental staff members will also more clearly understand and better communicate with co-workers departmental objectives, priorities and resources available to support their work. Such information sharing will also remain compliant with departmental confidentiality procedures.

In addition to the ongoing implementation of the tasks identified above, this Project has developed feedback and measurement strategies, by which to assess the impact of communication initiatives. These include spot/pulse surveys, communication surveys, leadership interviews, departmental staff member focus groups and skill-building follow-up. These surveys help to identify remaining challenges and to consider further steps to be taken to address them. Work will continue, to implement the Strategic Internal Communication Plan, while assessment of its impact will inform further implementation of the Plan with re-prioritized tasks.

In-house expertise would support the implementation of these activities based on the Strategic Internal Communication Plan. Further support will be welcome. Additional MSSP resources, including funding for consulting expertise would support the development of feedback and information sharing mechanisms as well as provide advisory support regarding other internal communication challenges.

SGAS-001: Destructive Analysis of Nuclear Materials

Project Manager: Steven BALSLEY

1. Overview

This chapter describes the plans for developing and implementing new or strengthened processes supporting laboratory practices related to destructive analysis of nuclear material samples for the 2020–2021 biennium.

Project objective

SGAS-001 is intended to facilitate access to new methodologies, technologies and knowledge that will allow the Department to sustain and enhance its destructive analysis (DA) capabilities in the Nuclear Material Laboratory (NML) at Seibersdorf and the On-Site Laboratory (OSL) in Japan. The project also surveys emerging DA technologies that hold promise for future applications in support of IAEA safeguards.

DA results are a direct source of independent, validated information that contributes to safeguards conclusions. The Department uses the work of this project to assure that its DA capabilities remain efficient, effective and reliable.

The overall objective is to improve existing DA capabilities and seek new DA technologies, through strengthened partnerships with subject matter experts and MSSP laboratories, including the formal Network of Analytical Laboratories (NWAL) utilized to support in-house activities. The Agency continuously seeks ways to improve DA quality (sampling, timeliness of analysis, uncertainty quantification and robustness) and efficiency (cost control and waste reduction) through advancements in hardware, software and analytical procedures.

Foreseen challenges

During the 2020–2021 biennium, the Rokkasho Reprocessing Plant in Japan may restart limited operations for the first time since 2008, which may require accelerated completion of current DA tasks. Should safeguards be re-established in the Democratic People's Republic of Korea, the SGAS-001 project may be used to support new methodological requests (for example, in plutonium (Pu) sample treatment and sample screening technologies).

Top project priorities in 2020–2021

- Install and validate new software for the controlled potential coulometry system in the NML.
- Conduct feasibility testing of microcalorimetry techniques for uranium and plutonium analysis.
- Develop and implement new algorithms for the hybrid k-edge densitometry (HKED) system for the OSL.
- Maintain supplies of reference materials and quality control standards for existing and new analytical techniques.

2. Strategy framework linkages

IAEA's Programme and Budget project linkage

The plan and MSSP tasks detailed in this chapter are followed-up and/or coordinated by Agency staff and are aligned with the objectives of the Agency's project #4.1.7.001 *Analytical services and sample analysis* in the *Agency's Programme and Budget 2020–2021*.

Safeguards Research & Development Plan linkage

Priority Objective	R&D Needs
T.2 Enhance sensitivity, reliability and timeliness in sample analysis	T.2.R1 Improve analytical timeliness of dealing with special and high priority demands for analysis by means of the reduction of sample size, the application of in-situ analysis and by strengthening the response regime (e.g., COMPUCEA, Cristallini method).
	T.2.R3 Support the improvement of Member States' analytical quality for nuclear material accountancy (i.e., for better operators' analytical systems).
	T.2.R4 Develop/expand a set of reference materials with NWAL assistance, and produce/distribute working reference materials to support Member States' analytical quality.
	T.2.R5 Continue to reduce and manage nuclear material holdings stored at the Nuclear Material Laboratory (NML) in line with safeguards needs, and identify long-term sustainable solutions for disposal of nuclear materials, particularly plutonium and highly-enriched uranium.

Collaborating D&IS projects

- SGAS-003: Analysis Support and NWAL Coordination
- SGIS-003: Safeguards Information Systems and System Usability
- SGTS-001: NDA Techniques

3. Progress on expected outcomes, key outputs and tasks from the previous biennium

Expected Outcome #1 from the 2018–2019 Biennium		
Improved analytical capabilities of the NWAL through development of new certified reference materials (CRMs), better preservation of existing stocks of CRMs, as well as enhanced use of working standards and new technologies for extending the shelf life of such working standards.		
Supporting R&D Needs: T.2.R4 and T.2.R5		
Key Outputs	Status	Comments
One to two laboratory-based workshops and/or training courses hosted in Seibersdorf in support of subject-specific topics identified by the IAEA in partnership with MSSPs and other safeguards laboratory stakeholders	Key output achieved; work completed	A technical meeting (TM) on the 2019 Nuclear Material Interlaboratory Comparison Exercise was held in Vienna, from 18–20 June 2019. 28 laboratories submitted results, including 4 NWAL members, 3 NWAL candidates and 7 facility operators.
One or two laboratory-based trials to test the application of novel materials for shelf life extension of large-sized dried spikes	Key output achieved; work continues	The NML conducted a laboratory trial using two different organic reagents on a subset of large-sized dried spikes. Further work is needed to evaluate feasibility for IAEA use.
Modernization of software for the NML controlled potential coulometry system, which is used for the validation of plutonium working standards	Delayed; nearing completion	Completion of the LabVIEW software is delayed until September 2020. Installation and training at NML also delayed.

Expected Outcome #2 from the 2018–2019 Biennium

Developed and implemented techniques for determination of new chemical and physical attributes for strengthening safeguards verification using nuclear material samples.

Supporting R&D Need: T.2.R1

Key Outputs	Status	Comments
Support for the field implementation of the COMPUCEA method in UF ₆ enrichment plants	Key output achieved; work continues	COMPUCEA approved for safeguards application in certain uranium enrichment plants.
Results of facility-scale testing of the ABACC-Cristallini UF ₆ sampling method, which will reduce sample size and circumvent potential future restrictions on air transports of traditional UF ₆ samples	Key output achieved; work continues	A workshop was held on 20 June 2019 in Vienna on the ABACC Cristallini UF ₆ sampling method. An update of the American Society for Testing and Materials (ASTM) standard was presented, as well as plans for facility testing in uranium (U) enrichment plants.
Development of quality control samples for new analytical techniques, for example, for the light impurity elements in uranium ore concentrate samples	Key output achieved; work continues	Production of reference materials with uranium matrices continues to be an important goal.

Expected Outcome #3 from the 2018–2019 Biennium

Enhanced analytical capabilities of the On-Site Laboratory (OSL) in Japan through capacity building and improved methodologies and techniques.

Supporting R&D Need: T.2.R3

Key Outputs	Status	Comments
Support for training and testing in destructive and non-destructive analytical systems as they apply to the OSL (including, but not limited to, approaches for the determination of Pu on undissolved particles, software development for improved evaluation of HKED results, and newcomer training in spent fuel reprocessing technologies)	Key output achieved; work continues	OSL staff members made a technical visit to the analytical labs at the La Hague Reprocessing Plant in Q4 2019.

4. Expected outcomes, key outputs and tasks for the 2020–2021 biennium

In order to achieve overall objectives and meet R&D needs, tasks must be initiated, continued and/or finalized during the 2020–2021 biennium. The following expected outcomes serve as an outline for the next 2 years.

Expected outcome #1	
Independent verification of Pu amount content in control samples and in-house reference materials through new DA software.	
Supporting R&D Need: T.2.R1	
Key Outputs	Expected Completion Date
Installation, testing, validation and training on new software for controlled potential coulometry (CPC) system for Pu assay in NML.	June 2020
Development, testing and implementation of new evaluation software for HKED at the OSL, Japan.	December 2021

Plans for accomplishing the expected outcome

- The CPC system is important for independent verification of Pu amount content in control samples and in-house reference materials. In collaboration with project SGIS-003: Safeguards Information Systems and System Usability, a major code rewrite of the CPC software is underway and is scheduled for installation in 2020. The IAEA may invite experts from MSSPs to observe the installation and training and may also hold a CPC workshop.
- The HKED system is the workhorse analytical technique used in the OSL in Japan. New software, utilizing recently developed advanced analysis algorithms, is needed to realize the full potential of the system. Identification of a software developer for the HKED task is in progress. In parallel, and in collaboration with project SGIS-003: Safeguards Information Systems and System Usability, the IAEA may seek to identify a suitably qualified intern, Junior Professional Officer or Cost Free Expert to assist with software development. The IAEA needs this software development work to be completed before the Rokkasho Reprocessing Plant goes into commercial operation, which may be in the 2021–2022 timeframe.

Expected outcome #2	
Continued independent information for making safeguards conclusions through new analytical methodologies for DA.	
Supporting R&D Needs: T.2.R1, T.2.R3 and T.2.R4	
Key Outputs	Expected Completion Date
Developed and validated plutonium/amerium-241 age determination method for nuclear samples containing Pu.	April 2020
A tested, validated and implemented third generation Combined Procedure for Uranium Concentration and Enrichment Assay (COMPUCEA).	December 2020
Implementation of a new scrubber for the OSL that removes radioactive ruthenium gas, which is released during dissolution of high-active liquid waste samples.	December 2021
Implementation of a new stirrer system for the OSL that determines Pu from undissolved particles in high-active liquid waste samples.	December 2021
New and tested microcalorimetry techniques for determining plutonium isotopic mass ratios in very small samples (sub-nanogram range).	December 2021
Testing of the Cristallini UF ₆ sampling method in commercial uranium enrichment plants for safeguards samples.	December 2021

Plans for accomplishing the expected outcome

- The IAEA relies on a variety of analytical methodologies and associated reference materials to determine the amount contents and isotopic compositions of samples containing uranium and/or plutonium. SGAS task officers will work closely with MSSP POCs to realize the key outputs listed above within the biennium timeframe.
- The scientific principles behind Cristallini UF₆ sampling are now well known. Acceptance of the technique is expected to progress well. Further evolution of the technique, perhaps in the direction of thin films, may also be explored in the 2020–2021 biennium.
- In 2021 the IAEA will host a TM focused on reference material needs for destructive analysis in the nuclear fuel cycle. Participants will review progress and to discuss new needs since the 2014 TM *Reference Materials for Destructive Analysis in the Nuclear Fuel Cycle*.

5. In-house development tasks

The table below lists internal development activities that will continue, but which will benefit from external contributions to the project. It gives an understanding of how external stakeholders can:

- Complement existing work
- Initiate activities in under-served areas of need
- Avoid duplicate activities

Expected outcome	Task #	Task Title (Agency's task cross reference)	Description	Expected Completion Date
Produce new mixed U-Pu glass beads for HKED quality control	1	USA A 02091 (Support for HKED Hardware and Software Testing)	The use of mixed U-Pu glass beads for quality control of the HKED systems at OSL will eliminate the need to use liquid samples. Evaporation causes the concentration of liquid QC samples to increase over time, thus limiting their useful life.	June 2020
Disposition of residual plutonium inspection samples	2	USA A 1081 (Support to SAL)	The NML has approximately 80 g of Pu in accumulated residual inspection samples. The disposition of this material will assure that the Pu inventory of the NML remains well below regulatory levels.	December 2020
Upgrade of COMPUCEA detectors and digital multichannel analysers	3	EC A 02003 (COMPUCEA Adaptation to the Analysis of Uranium Hexafluoride Material)	The new components will allow for improved relative standard deviation (0.14%) and almost complete elimination of the bias between NU and LEU. Additionally the reduced dimensions of the detectors setup will allow the size and footprint of the COMPUCEA system to be reduced significantly, enhancing portability.	December 2020

6. Attachments



Figure 2: 2019 Technical Meeting on Nuclear Material Round Robin



Figure 3: Aliquoting samples in the Pu Lab



Figure 4: Bagging out samples in Pu Lab



Figure 5: NML Chemist treating samples in glove box



Figure 6: Preparation of uranium samples for measurement



Figure 7: Pu solution weighing in glove box

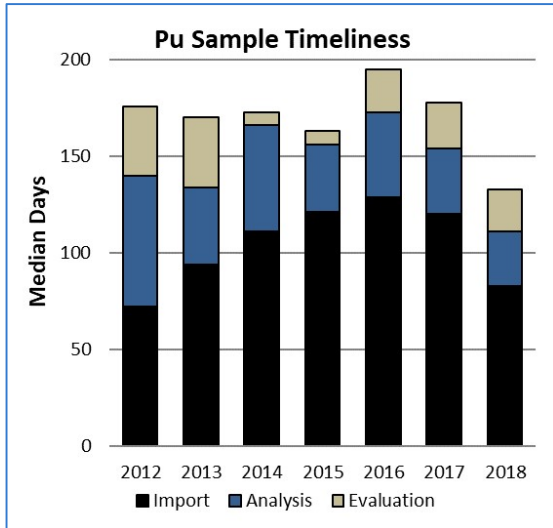

Figure 8: Pu Timeliness Plot 2012-2018

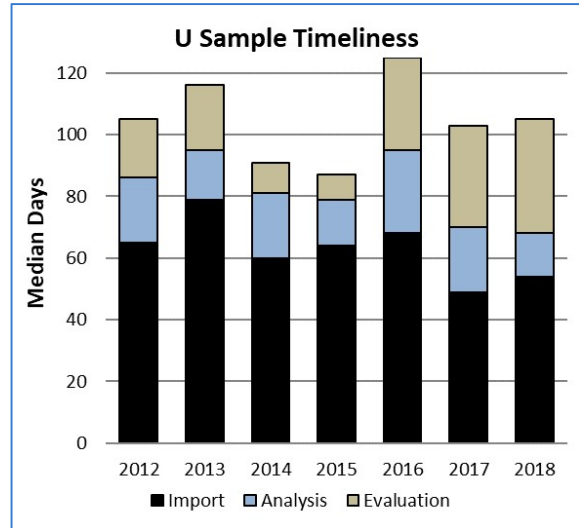

Figure 9: U Timeliness Plot- 2012-2018

SGAS-002: Environmental Sample Analysis Techniques

Project Manager: Matthew KILBURN

1. Overview

This chapter describes the plans for developing and implementing advanced analytical methods and quality control materials, during the 2020–2021 biennium, for the analysis of environmental samples.

Project objective

The main purpose of the Agency's Environmental Sample Laboratory (ESL) is to provide timely, accurate and precise analytical data from environmental samples collected by safeguards inspectors. This data provides input to the State evaluation process and may constitute an important factor in drawing safeguards conclusions on the presence of undeclared nuclear material and activities.

The detection and measurement of uranium (U) or plutonium (Pu) isotopes, either in the whole environmental sample ('bulk analysis'), or in individual micrometer-sized particles ('particle analysis'), is key to the work of the ESL. Operations at the ESL currently include the bulk analysis of environmental swipe samples by inductively-coupled-plasma - mass spectrometry (ICP-MS) and the analysis of particles by large-geometry - secondary-ion mass spectrometry (LG-SIMS). This requires state-of-the-art analytical instrumentation, supported by highly-skilled staff. To remain at the forefront of support to the independent verification of nuclear activities through environmental sampling, the ESL must stay abreast of emerging technologies; facilitate the development of, and implement improvements to, existing technologies and maintain high standards of data quality through the continued development of comprehensive quality assurance/quality control (QA/QC) management systems. In addition, the ESL continues to share expertise and provide support to Member States and the Agency's Network of Analytical Laboratories (NWAL), to enhance the overall capacity and capability to measure environmental samples in support of safeguards.

This project aims to address these issues by identifying and developing techniques that generate new or complementary data or information that can be applied to different types of material present in environmental samples for the shared benefit of the ESL and the NWAL.

Foreseen challenges

To realize the potential opportunities offered by environmental sampling to input important safeguards-relevant information to the State evaluation process, the requirements from evaluators for additional data from environmental samples continue to evolve. These include:

- the analysis of particles containing low levels of Pu or mixed U/Pu
- isotopic measurements to determine the age of particles (for example, the date of separation of plutonium)
- the elemental and physical characterisation of particles containing U and Pu

Behind the associated analytical challenges lies the need for development and/or implementation of improved techniques to screen, locate and manipulate particles of interest, to enable better-targeted, more efficient and effective analysis.

Providing assurance of the accuracy of data obtained through environmental sampling requires the application of quality control (QC), both within the ESL and across the NWAL. QC materials are used to assess the performance of analytical laboratories, providing assurance of the quality and reliability of data to support the drawing of safeguards conclusions. However, QC materials for particle analysis are extremely difficult to produce in quantities sufficient for use across the NWAL, requiring specialized production facilities and meticulous characterisation before they can be certified.

A further challenge lies in maintaining the Agency's ability to provide a timely and independent capability that meets the requirements of safeguards evaluators for the provision of data from environmental samples. A long-term sustainability strategy is essential, both in terms of infrastructure and staff expertise.

Top project priorities in 2020–2021

- Development of new methodologies for the age determination of particles in environmental samples using LG-SIMS.
- Development of new methodologies for using the Scanning Electron Microscope (SEM) and Time-of-Flight (ToF) SIMS capability to characterize individual particles collected on environmental swipe samples.
- Implementation of the Laser-Ablation (LA) ICP-MS technique for the measurement of particles containing low levels of Pu or mixed U/Pu.

2. Strategy framework linkages

IAEA's Programme and Budget project linkage

The plan and MSSP tasks detailed in this chapter are followed-up and/or coordinated by Agency staff and are aligned with the objectives of the Agency's project #4.1.7.001 Analytical services and sample analysis in the *Agency's Programme and Budget 2020–2021*.

Safeguards Research & Development Plan linkage

Priority Objective	R&D Needs
T.2 Enhance sensitivity, reliability and timeliness in sample analysis	T.2.R2 Further improve the quality assurance and control (QA/QC) for the Agency's NWAL for safeguards, including SAL, in the area of particle analysis in particular.
	T.2.R4 Develop/expand a set of reference materials with NWAL assistance, and produce/distribute working reference materials to support Member States' analytical quality.
	T.2.R6 Develop and implement methods to detect signatures of nuclear activities in environmental samples including: <ul style="list-style-type: none">• Age determination of U and Pu relevant to the origin of nuclear materials• Analysis of impurities relevant to the origin of source materials• Particles morphology for identifying operational processes• Reliably finding smaller particles of interest in an excess of background material• Isotopic characterisation of Pu containing particles using FT-LAICPMS and LG-SIMS

Collaborating D&IS projects

- DDGO-001: Overall Safeguards Management and Coordination
- SGAS-003: Analysis Support and NWAL Coordination
- SGIM-007: Evaluation of Data from Environmental Sampling and Material Characterisation

3. Progress on expected outcomes, key outputs and tasks from the previous biennium

Expected Outcome #1 from the 2018–2019 Biennium

Provision of external quality control and reference materials, as well as technical expertise, through optimized utilization of the expanded NWAL.

Supporting R&D Needs: T.2.R2 and T.2.R4

The IAEA will continue to make use of the competences and resources of the NWAL and associated laboratories to develop new reference material (RM) and quality control (QC) materials for safeguards particle analytical investigations, and certified reference materials (CRM) for instrumental calibrations and method validations.

Key Outputs	Status	Comments
Working group report on way forward for an optimized and prioritized provision of particle materials.	Key output achieved; work continues	In 2018, consultants from the <i>Working Group on Particle QC Materials</i> reported their recommendations. Subsequent Technical Meetings and Working Groups will continue to address an optimized strategy.
Additional reference and quality control materials (about one per year) to carry out a sound external quality control programme administered through the NWAL.	Key output achieved; work continues	This activity will continue.

Expected Outcome #2 from the 2018–2019 Biennium

Developed techniques, methods and equipment to detect signatures of nuclear activities in environmental samples.

Supporting R&D Needs: T.2.R2 and T.2.R6

Key Outputs	Status	Comments
Implementation of the laser ablation (LA) sampling technique in combination with inductively coupled plasma mass spectrometry (ICP-MS) to analyse plutonium and mixed uranium/plutonium particles complementing the existing capability of isotopic characterisation of uranium containing particles using LG-SIMS.	Delayed; nearing completion	Implementation of the LA-ICP-MS technique will continue.
Implementation of the Fission Track particle identification method.	Delayed; work in progress	Implementation of the Fission Track method will continue.
Report on a feasibility study on isotopic characterisation of plutonium containing particles using LG-SIMS.	Key output achieved; work completed	It was decided not to proceed. No further action.

Expected Outcome #3 from the 2018–2019 Biennium

Established plan for equipment replacement, including resource mobilization strategy, to ensure the sustainability of the ESL's operations in terms of capabilities and capacities.

Supporting R&D Need: T.4.R2

Key Outputs	Status	Comments
Equipment replacement plan and strategy for fund mobilization	Key output achieved; work continues	A report on the sustainability of capital equipment in SGAS was produced by a consultant in 2018. The key output is ongoing, as the plan requires continuous input from Member States.

4. Expected outcomes, key outputs and tasks for the 2020–2021 biennium

In order to achieve overall objectives and meet R&D needs, tasks must be initiated, continued and/or finalized during the 2020–2021 biennium. The following expected outcomes serve as an outline for the next 2 years.

Expected outcome #1

Provision of external quality control and reference materials, as well as technical expertise, through optimized utilization of the expanded NWAL.

Supporting R&D Needs: T.2.R2 and T.2.R4

Key Outputs	Expected Completion Date
Reports from Technical Meetings, the Working Group and 'Friends of SAL' containing recommendations for the provision of particle QC material.	December 2021 and ongoing
Additional reference and QC materials (about one per year) to be made available for internal and external quality control programmes administered through the NWAL.	December 2021 and ongoing

Plans for accomplishing the expected outcome

The initial development of environmental sampling in support of safeguards verification activities included developments both in the application of instrumentation for particle analysis and also the materials required for quality control of sample measurements. The latter resulted in the availability of a limited range of QC materials, which met the immediate needs of demonstrating analytical capability but lacked the detailed specifications or rigorous certification that subsequent advances in instrumentation and requirements from safeguards evaluators now demand.

Reference and QC material production for particle analysis is difficult. This is due to challenges in fabricating the microscopic particles containing fissile material, required to be within a well-constrained and homogeneous composition and in the subsequent rigorous characterisation of these materials. The ESL has largely continued to rely upon the early materials—some of which are now 20 years old—supplemented by the periodic production of particles at a range of laboratories; without sustainability of supply or the diversity of compositions desirable for a rigorous quality control programme.

A working group on particle QC production was convened by the Agency in 2016 and has met on an annual basis thereafter. This group of international experts reviews requirements, identifies specifications, sets priorities and advises on appropriate solutions to produce the particle QC materials required. Early recommendations of the group were that the IAEA lead the overall preparation of environmental sample QC 'swipes' for distribution to the NWAL, using as input particle materials produced by outside laboratories. The need to ensure sustainability and to identify and secure appropriate resources for the production of particle QC materials and QC swipes called for extended cooperation with the Member State Support Programmes (MSSPs) in this area. This cooperation has resulted in several ongoing MSSP tasks for QC material production, each of which plays an important role in the overall programme.

MSSP task GER A 1961 (Production of Particle Reference Materials) involves the production of mono-disperse particles using a 'Vibrating Orifice Aerosol Generator'. This task is a trilateral effort between the German Support Programme, the European Commission Support Programme and the IAEA. The recent technical achievements reported by Forschungszentrum Jülich (FZJ), Germany, on the production of mono-disperse U particles are extremely promising, and the suitability of these

particles for use in quality assurance has been demonstrated. The mono-disperse nature of the particles lends itself to instrument calibration and method validation, in addition to QC material production. FZJ is currently undergoing formal qualification as a member of the NWAL under MSSP task GER A 1960 (Qualification of a Lab for the IAEA Network of Analytical Labs (NWAL) for Destructive Analysis of Nuclear Materials) under Project SGAS-003. It is anticipated that this initiative will facilitate one route to sustainable production of particles for QA/QC. Additional work is anticipated under MSSP task GER A 1961 (Production of Particle Reference Materials) to find complementary methods for collecting mixed uranium-thorium (U-Th) mono-dispersed QC particles. The task will also include the characterisation of produced batches before these are shipped to the IAEA.

MSSP task EC A 1966 (Production of Particle Reference Materials) supports the preparation of feed solutions from bulk certified reference materials (CRMs), used for particle production at the FZJ, and characterisation and certification of particles as reference materials. These activities are undertaken by the European Commission Joint Research Centre (EC-JRC) in Geel, Belgium. Feed solutions from additional CRMs and new mixtures of CRMs are in preparation.

MSSP task USA A 2370 (Production of Particle Reference and Quality Control Materials) involves the production of mono-disperse particles using two methods:

- Vibrating Orifice Aerosol Generator
- Colloidal chemistry (hydrothermal synthesis)

This task involves several United States of America Department of Energy (DOE) laboratories and includes production and characterisation of particle batches. Thus, the deliverable to the IAEA is the particle batch together with an accompanying characterisation report. The batches will be used mainly for the production of internal and external QC samples.

The three MSSP tasks described above are anticipated to continue and form the backbone of the Agency's strategy to develop sustainable resources for quality control in particle analysis. Through Working Group Meetings, MSSPs and the 'Friends of SAL,' the Agency will seek to continue to remain abreast of potential new sources of reference materials that might further assist in optimum delivery of its environmental sample analysis activities.

Expected outcome #2

Improved detection of signatures of undeclared nuclear activities in environmental samples through the development, implementation and improvement of techniques, methods and equipment.

Supporting R&D Need: T.2.R6

Key Outputs

Expected Completion Date

Implementation of the laser ablation-inductively coupled plasma mass spectrometry (LA-ICP-MS) technique to analyse Pu and mixed U/Pu particles in environmental samples.	December 2020
Implementation of identification methods to find and isolate Pu-containing particles for analysis by LA-ICP-MS, including Fission-Track techniques, LG-SIMS and SEM.	December 2020
Development and implementation of a methodology for the elemental analysis of particles using the ToF-SIMS capability of the ESL's TESCAN Lyra SEM.	December 2021
Development and implementation of methodologies for the age determination of particles using LG-SIMS.	December 2021
Report on a feasibility study to enhance the sensitivity of detection of U and Pu isotopes using mass spectrometry methods.	December 2021

Plans for accomplishing the expected outcome

A key objective of the ESL is to develop and implement new and complementary techniques to enable the detection of signatures of undeclared nuclear activities in environmental samples. Significant progress was made in the development of several techniques during 2018–2019, and it is anticipated that these developments will be implemented as routine analytical methodologies within the ESL during 2020–2021.

Under MSSP task FRA A 1565 (Technical Support for ICP MS Measurements), departmental staff members will be trained at a laboratory of the Commissariat à l'Énergie Atomique et aux Énergies Alternatives (CEA), France, in the highly-sensitive measurement of U and Pu by ICP-MS. Meanwhile,

MSSP task EC B 1752 (Training on Mass Spectrometry and Other Analytical Techniques) will continue to provide training in a range of analytical techniques, including Thermal-Ionisation Mass Spectrometry (TIMS), ICP-MS and LG-SIMS, using relevant expertise of the EC-JRC laboratories at Geel, Belgium and Karlsruhe, Germany.

MSSP tasks RUS A 1957 and SWE A 1928 (Support for Large-Geometry Secondary Ion Mass Spectrometry for Analysis of Environmental Samples) and UK A 1776 (Implementation Support to Environmental Sample Laboratory) will continue during the coming biennium, providing the platform for collaboration between ESL staff and relevant LG-SIMS facilities in Russia, Sweden and the United Kingdom, respectively. The objective of these tasks is to improve measurement protocols, data reduction and reporting of LG-SIMS data for safeguards purposes in cooperation with SIMS experts.

MSSP task JPN A 1845 (Sample Preparation for Particle Analysis) involves the ongoing development of improved methods of sample preparation for LG-SIMS. Methods with the potential to improve the efficiency of sample preparation will be tested. The results will be used within the ESL to implement improvements to existing sample preparation processes and further communicated to members of the NWAL for their consideration. Following its successful trial application to the measurement of U- and Pu-containing reference materials, the next stage in the ongoing development of LA-ICP-MS for safeguards—to provide isotopic analysis of Pu and mixed U/Pu particles—will involve test measurements on field samples. The system currently relies upon identification and relocation of particles by SEM, with subsequent analysis by multi-collector (MC) ICP-MS coupled to a femtosecond laser. Due to the Pu-containing nature of the samples, this work has been confined to the Low-level Laboratory housed within the Nuclear Materials Laboratory (NML).

The ESL has recently installed a new nanosecond laser, to be used with the MC-ICP-MS in the Clean Laboratory. After completion of validation and training, the new system will be used for method development and eventually replace the femtosecond laser for isotopic analysis of Pu-containing particles in the Low-level Laboratory. The anticipated key output of 2020–2021 will be to validate this technique as a routine analytical service. The ESL would benefit from further development and collaboration with experts from Member States.

A number of ESL staff are actively involved in developing and implementing methods to identify U- and Pu-containing particles in a matrix of non-nuclear material for analysis by LA-ICP-MS. Particle identification by SEM is limited to larger particles or particles that contain higher amounts of U and Pu. A fission-track method has been identified as having greater potential to identify smaller particles containing highly enriched uranium (HEU), Pu or uranium-233 targets, such as expected infield samples. MSSP tasks CZ A 2007 and FRA A 2002 (Fission Track Technique for Spatially-Resolved Analysis of U and Pu Particles in Swipe Samples) and FIN A 2416 (Feasibility study: Use of high intensity neutron generator based system for fissile particle detection and identification) continue to support development of the fission track technique to identify particles-of-interest (POIs). MSSP tasks CZ A 2007 and FIN A 2416 will continue to develop procedures for sample treatment, while MSSP task FRA A 2002 will develop methods of identifying and manipulating POIs prior to isotopic measurement. The anticipated key output will be to validate a fission-track-based method for locating particles, in tandem with the validation of the LA-ICPMS measurement technology.

An increasingly important requirement of safeguards evaluators is the ability to differentiate between different activities within a facility. Combinations of physical, elemental and isotopic properties of individual ES particles may yield important information to assist in this area, and a number of contributions are in progress towards meeting this need.

The ESL has continued to develop capabilities for the elemental and morphological characterisation of particles, and a sophisticated SEM (TESCAN Lyra 3) has been recently validated for the analysis of environmental samples. The expertise provided through MSSP task GER A 2404 (Junior Professional Officer - Associate SIMS Analyst), has extended SEM characterisation to samples analysed by LG-SIMS. A key development goal for 2020–2021 is an investigation into the efficacy for safeguards application of advanced analytical capabilities attached to the Lyra SEM. These extended capabilities should allow the combination of SEM imaging with the low detection limits of SIMS, to determine which elements are present within a particle. The benefit over traditional analysis is that the instrument can be focused in a manner which allows a greater degree of specificity. However, significant development is required in this area. The anticipated key output is to validate a method to locate particles of interest (using either in-built automated particle search capabilities, fission-track or LG-SIMS) and provide images and elemental composition of the particles.

Methods already exist capable of application to determine the length of time since chemical separation or irradiation of a bulk quantity of nuclear material. However, isotopic approaches at the scale of an individual or cluster of particles (in other words, picogram to nanogram amounts) are more challenging due to the large uncertainties associated with low counting statistics in mass spectrometry. MSSP task JPN A 1679 (Age Determination of Uranium and Plutonium Particles)

involves the development of methods to measure radioactive decay products, as a means of determining the age of a material since its last chemical purification. Current activities are focused on improvement of the accuracy and precision and viable schemes for U particle measurements utilizing LG-SIMS. This key emerging technology needs to be assessed and validated before its use in drawing safeguards conclusions.

In order to reliably measure and quantify extremely small amounts of analytes in environmental samples, an analytical technique offering high sensitivity is of crucial importance. This is especially true when it comes to the determination of low abundance isotopes such as U-233, U-234, U-236, Th-230 and isotopes of transuranium elements (Pu, Americum, etc.). The ESL is looking at novel approaches to enhance the detection sensitivity, in particular by using high-efficiency sample introduction systems in MC-ICP-MS and improvements in the ion source design for TIMS. Member States are invited to contribute to a feasibility study that will assess the current R&D status and facilitate knowledge exchange between the IAEA and NWAL specialists in the field of high-sensitivity mass spectrometric equipment for analysis of environmental swipe samples.

Expected outcome #3	
Ensured sustainability of the ESL's operations in terms of capabilities and capacities by establishing a plan for infrastructure replacement and resource utilization.	
Supporting R&D Need: T.4.R2	
Key Outputs	Expected Completion Date
Action plan for the replacement of analytical and ancillary equipment with strategy for fund mobilization.	December 2021

Plans for accomplishing the expected outcome

The ability to maintain the capability and capacity of analytical services provided by the ESL is dependent upon departmental staff resources and the effective and timely replacement of analytical equipment, before its reliability becomes a constraint on performance. The ESL currently maintains highly sophisticated mass spectrometers, microscopes and screening tools, along with ancillary equipment, with a total replacement value of approximately €10 million. Replacement of the LG-SIMS (approximately €5 million) will be necessary within the next few years, followed by the ICP-MS platforms. The sustainability of ESL operations continues to be discussed within the Department and together with Member States. In 2017, SGAS commissioned a report, which outlined a decadal plan for instrument replacement. Further development and implementation of this plan requires the continued support of external stakeholders, to ensure the Agency's ability to provide independent, fit-for-purpose analytical services.

5. In-house development tasks

The table below lists internal development activities that will continue, but which will benefit from external contributions to the project. It gives an understanding of how external stakeholders can:

- Complement existing work
- Initiate activities in under-served areas of need
- Avoid duplicate activities

Expected outcome	Task #	Task Title (Agency's task cross reference)	Description	Expected Completion Date
1	1	Production of QC materials	Produce new QC swipes for particle and bulk analytical techniques.	December 2021
	2	Improve particle micro-manipulation techniques	Provide feedback to particle producers on the characteristics of their particles relevant to manipulation for use in making QC swipes.	December 2020
2	1	Improved measurement systems for screening swipe samples	Development of an improved automated XRF system, for screening swipe samples prior to sending them to the NWAL for detailed analysis.	December 2021

	2	Installation of MMXRF system	Purchase and installation of a commercial high sensitivity system for screening of swipe samples prior to LG-SIMS analysis.	December 2020
	3	New QC and reporting software	Improving and implementing a QC and reporting software for LG-SIMS analysis.	December 2020
	4	Improved relocation technique	Development of a more timely and precise relocation technique between optical microscopes, SEM and LG-SIMS.	December 2020

6. Attachments



Figure 10: The IAEA ESL SEM Laboratory

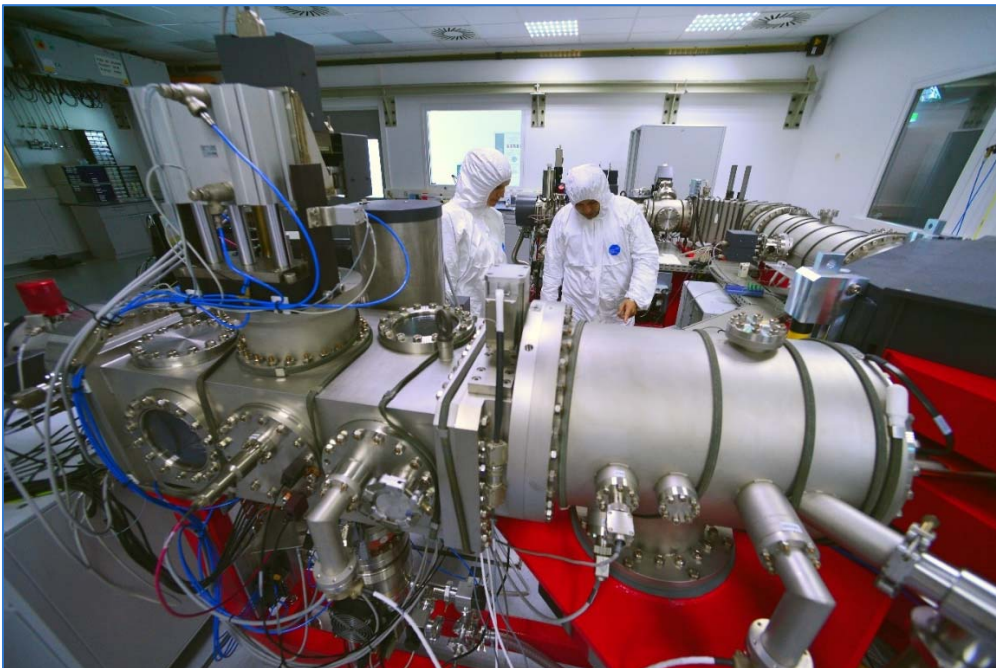

Figure 11: ESL LG-SIMS

SGAS-003: Analysis Support and NWAL Coordination

Project Manager: Not available

1. Overview

This chapter describes the plans for developing and implementing analysis support and coordination of the IAEA Network of Analytical Laboratories (NWAL) for the 2020–2021 biennium.

Project objective

The IAEA collects nuclear material and environmental samples during safeguards inspections in order to verify the correctness and completeness of Member State declarations regarding their nuclear activities. Nuclear material sample analysis primarily supports the material balance evaluations used to verify Member State declarations of nuclear material holdings. Environmental sample analyses are focused on the detection of undeclared nuclear materials and activities. Environmental samples are generally analysed by two complementary analytical methodologies, referred to as bulk and particle analysis. Bulk analysis is performed on the whole sample and determines the total amounts of uranium (U) and plutonium (Pu), together with their average isotopic compositions in the sample. Particle analysis techniques are used to measure the U and Pu isotopic composition of individual particles.

Samples collected by safeguards inspectors are analysed by the NWAL. Currently, the NWAL includes the Agency's Environmental Sample Laboratory (ESL) and Nuclear Material Laboratory (NML) in Seibersdorf, plus 23 external laboratories from ten Member States and the European Commission. End-users of the NWAL analysis reports are members of State evaluation teams.

The overall objective of SGAS-003 is to enhance the effectiveness and efficiency of the NWAL's provision of analytical support to the IAEA's verification mission, in particular with respect to sample analysis capabilities, capacity, quality and timeliness.

Foreseen challenges

Successful implementation of IAEA safeguards is dependent, in part, upon maintaining an effective and efficient combination of Agency and Member States' analytical capabilities. The latter includes both facility operators' measurement systems, in terms of nuclear material accountancy, and the provision of analytical support to the Agency from the external NWAL members. Achieving an optimum balance between the Agency's in-house activities and those of the wider NWAL in support of the Agency's verification mission requires continued close collaboration between laboratories, with engagement and understanding of requirements, capabilities and limitations at both technical and managerial levels. Continual monitoring and regular assessment of contributions is required, with effective communication between all parties.

Through Member State Support Programmes (MSSPs), some members of the NWAL, and other external laboratories, play an essential role in the provision of highly-specialized certified reference materials, required for the traceability and/or quality control (QC) of sample measurements. Although significant progress continues to be made, challenges remain in addressing the diversity of requirements for such materials. In particular, the need for an expanded range of reference materials for uranium and plutonium particle analysis remains to be fully addressed.

Further strengthening of the NWAL QC programme requires a collaborative approach, involving engagement in external proficiency testing of NWAL performance combined with the Agency's monitoring and reporting of analytical performance in terms of timeliness and quality.

Various challenges, specific to those NWAL members that analyse nuclear material samples, remain to be fully addressed. Foremost amongst these is the challenge of international shipment of accountancy-size samples of nuclear material and the disposal of sample residues that would otherwise accumulate at the Agency's laboratories.

Top project priorities in 2020–2021

- Ensure efficient and effective operation of the NWAL, including participation in inter-laboratory comparison exercises.
- Expand the NWAL, with the main focus on overall capacity and quality assurance of particle analysis of environmental samples.
- Increase capacity for the safe and secure shipment of nuclear material samples and disposal of analytical residues.

2. Strategy framework linkages

IAEA's Programme and Budget project linkage

The plan and MSSP tasks detailed in this chapter are followed-up and/or coordinated by Agency staff and are aligned with the objectives of the Agency's project #4.1.7.001 Analytical services and sample analysis in the *Agency's Programme and Budget 2020–2021*.

Safeguards Research & Development Plan linkage

Priority Objective	R&D Needs
T.2 Enhance sensitivity, reliability and timeliness in sample analysis	T.2.R2 Further improve the quality assurance and control (QA/QC) for the Agency's NWAL for safeguards, including SAL, in the area of particle analysis in particular.
	T.2.R3 Support the improvement of Member States' analytical quality for nuclear material accountancy (i.e., for better operators' analytical systems).
	T.2.R4 Develop/expand a set of reference materials with NWAL assistance, and produce/distribute working reference materials to support Member States' analytical quality.

Collaborating D&IS projects

- SGAS-001: Destructive Analysis of Nuclear Materials
- SGAS-002: Environmental Sample Analysis Techniques
- SGIM-007: Evaluation of Data from Environmental Sampling and Material Characterisation
- SGIS-003: Safeguards Information Systems and System Usability

3. Progress on expected outcomes, key outputs and tasks from the previous biennium

Expected Outcome #1 from the 2018–2019 Biennium			
Expanded IAEA Network of Analytical Laboratories (NWAL) and quality controlled analytical services. Supporting R&D Needs: T.2.R2, T.2.R3 and T.2.R4			
Key Outputs	Status	Comments	
Qualification of one additional NWAL member for the analysis of safeguards samples.	Key output achieved; work continues	National Nuclear Laboratory (NNL) Preston, in the United Kingdom, was qualified as a member of the NWAL in October 2019.	
Qualification of one additional NWAL member for provision of reference materials.	Delayed; nearing completion	Qualification of the Forschungszentrum Jülich, Germany, for provision of reference materials for Environmental Sampling (ES) particle analysis, is nearing completion.	
Organisation of one to two inter-laboratory comparison exercises per year.	Key output achieved; work continues	Three new inter-laboratory comparison exercises were organized and completed during the biennium, with a further two exercises from 2017 concluded during the period. These were reported in the areas of: destructive analysis of nuclear material (2019); ES bulk analysis (2 exercises in 2018); high resolution gamma spectrometry (2018) and ES particle analysis (2019).	

Expected Outcome #2 from the 2018–2019 Biennium

Maintained and upgraded Safeguards Analytical Laboratory Information Management System (SALIMS).

Supporting Priority Objective: T.2

Key Outputs	Status	Comments
Release of upgraded SALIMS v1.1	Delayed; work in progress	Under the SALIMS project, the resource-intensive and high-priority task of re-engineering the Mass Spectrometry Data Evaluation System (MSDES) is well-advanced; core functionalities have been deployed for parallel testing. Development of complementary functionalities will be pursued until August 2020 (Task USA D 2353 (SALIMS v1.1 Development Project / Software Development Support: LIMS for the SAL)). Other development tasks under the SALIMS project have progressed using internal resources. The Laboratory Information Management System (LIMS) for the NML was further developed, and modules of the ESL LIMS were successively rolled out in 2018 and 2019.

4. Expected outcomes, key outputs and tasks for the 2020–2021 biennium

In order to achieve overall objectives and meet R&D needs, tasks must be initiated, continued and/or finalized during the 2020–2021 biennium. The following expected outcomes serve as an outline for the next 2 years.

Expected outcome #1

Broader capabilities and increased capacity of the IAEA Network of Analytical Laboratories (NWAL) for timely, high quality analysis of safeguards samples.

Supporting Priority Objective: T.2

Key Outputs	Expected Completion Date
Qualification of one or more additional NWAL member for the analysis of safeguards samples.	December 2021

Plans for accomplishing the expected outcome

This outcome ensures that the NWAL has sufficient capacity and capability to complement the Agency's in-house resources for the analysis of samples collected by safeguards inspectors, with arrangements in place to mitigate a temporary loss of analytical service within one or more active laboratory. In addition to sample analysis, the NWAL should also provide a measurement quality control (QC) function, manufacture and supply reference materials and offer a pool of expertise in the analysis of safeguards samples. During NWAL technical meetings, a community of experts from the NWAL reviews analytical practices, shares information on method improvements and revises technical objectives for performance monitoring.

In recent years, the Agency has sought to further optimize the NWAL, including the qualification of new members. This process will continue through the 2020–2021 biennium; supporting the analyses provided by the existing members and adding additional qualified laboratories to fulfil identified roles within the network.

Particle analysis of environmental samples is currently undertaken by the IAEA ESL plus nine NWAL members:

- University of Western Australia (UWA), Australia
- China Institute of Atomic Energy (CIAE), China
- European Commission Joint Research Centre (EC-JRC) (Karlsruhe), EC
- Commissariat à l'Énergie Atomique et aux Énergies Alternatives (CEA), France
- Japan Atomic Energy Agency (JAEA), Japan
- Korea Atomic Energy Research Institute (KAERI), Republic of Korea
- Laboratory for Microparticle Analysis (LMA), Russian Federation
- Atomic Weapons Establishment (AWE), UK
- Air Force Technical Applications Center (AFTAC), USA

Six MSSP tasks—AUL A 0859 (Analytical Services for Environmental Sampling), EC X 1969 (Analysis of Environmental and Nuclear Samples Supplied by IAEA), JPN X 2004 (Analysis of Environmental Samples supplied by IAEA), ROK X 2265 (Analysis of Environmental Samples supplied by the IAEA), RUS X 1515 (Analysis of Environmental Samples Supplied by IAEA) and UK X 1045 (Analysis of Environmental Samples Supplied by IAEA)—support the contributions provided by relevant NWAL members, with a further two tasks—FRA X 1941 (Support for Analytical Services) and USA A 1081 (Support to SAL)—providing more general support to the ESL¹.

The IAEA seeks additional capacity within the NWAL for particle analysis, in particular from laboratories using the techniques of large geometry-secondary ion mass spectrometry (LG-SIMS) and fission-track thermal ionization mass spectrometry (FT-TIMS).²

Bulk analysis of environmental samples is carried out by the IAEA ESL plus ten NWAL members:

- Australian Nuclear Science and Technology Organization (ANSTO), Australia
- Instituto de Radioproteção e Dosimetria (IRD), Brazil
- Commissariat à l'Énergie Atomique et aux Energies Alternatives (CEA), France
- Japan Atomic Energy Agency (JAEA), Japan
- Korea Atomic Energy Research Institute (KAERI), Republic of Korea
- Khlopin Radium Institute (KRI), Russian Federation
- Four laboratories of the United States Department of Energy (USDOE)
 - Los Alamos National Laboratory (LANL), USA
 - Lawrence Livermore National Laboratory (LLNL), USA
 - Oak Ridge National Laboratory (ORNL), USA
 - Pacific Northwest National Laboratory (PNNL), USA
- Four MSSP tasks—AUL A 0859, JPN X 2004, ROK X 2265 and RUS X 1515 (Analysis of Environmental Samples supplied by the IAEA)—support bulk analysis activities. At present, no new laboratories are undergoing qualification for the NWAL for bulk analysis. The IAEA would benefit from Member State nominations of experienced laboratories to begin the qualification process for bulk analysis.

All nuclear material sample analyses for accountancy purposes are currently performed by the IAEA NML. However, support from the NWAL is required for quality assurance purposes and to provide backup capacity in the event that the NML is unavailable. Three laboratories are currently qualified to receive, prepare and analyse safeguards samples in support of the Agency's evaluation of nuclear material accountancy data:

- European Commission Joint Research Centre (EC-JRC) (Karlsruhe), EC (Task EC X 1969 (Analysis of Environmental and Nuclear Samples Supplied by IAEA))
- CEA Laboratoire d'Analyses Nucléaires Isotopiques et Élémentaires (LANIE), France
- United States Department of Energy Savannah River National Laboratory, USA

Three more laboratories—in Belgium, Canada and the Netherlands—are currently under qualification for this purpose under MSSP tasks BEL A 1758, CAN A 1950 and NET A 1974 (Qualification of the IAEA Network of Analytical Laboratories (NWAL) for Analysis of Nuclear Materials)). Between the three qualified NWAL members plus three qualifying laboratories, the Agency will have sufficient capacity to address present needs in this area.

Nuclear material samples are collected not only for accountancy verification. Additional or alternative analyses may be required, for example to support an investigation into the accuracy or completeness of a declaration. While the IAEA NML is equipped to perform many of these types of analysis, additional support is provided by several laboratories, including JRC Karlsruhe through MSSP task EC X 1969 (Analysis of Environmental and Nuclear Samples Supplied by IAEA), CEA, LANL, LLNL, ORNL, PNNL and the UK National Nuclear Laboratory's (NNL) Preston laboratory through MSSP task UK C 1742 (Implementation Support to Nuclear Material Lab).

One laboratory is currently qualified under the NWAL for analysis of heavy water samples: the Magyar Tudományok Akadémia (MTA) in Hungary. To add supplementary capacity in this area, one additional laboratory is under qualification in Argentina through MSSP task ARG A 1906 (NWAL Qualification for Heavy Water Laboratory).

¹ Additional support to the ESL is also provided through a number of tasks within project SGAS-002: Environmental Sample Analysis Techniques.

² Separately, the IAEA is working to develop, in-house, a fission-track analysis capability in conjunction with two MSSPs; details of this effort are provided in SGAS-002.

Expected outcome #2

Strengthened quality assurance of IAEA Network of Analytical Laboratories (NWAL) analytical services.

Supporting R&D Needs: T.2.R2, T.2.R3 and T.2.R4

Key Outputs

Expected Completion Date

Qualification of one additional NWAL member for the provision of reference materials. March 2020

Organization of one to two inter-laboratory comparison exercises per year. December 2021

Plans for accomplishing the expected outcome

The availability of fit-for-purpose reference materials is a cornerstone of analytical QC. Such materials are necessary for proper instrument calibration, traceability to the International Organization for Standardization (ISO) standards, measurement control, uncertainty quantification and external quality control purposes. Through a number of MSSP tasks, laboratories with unique capabilities and/or particular expertise in the production and certification of reference materials continue to develop highly-specialized materials for quality control of analytical performance in support of safeguards.

Four members of the NWAL prepare such reference materials, with support under MSSP tasks EC A 0318 (Special Reference and Source Materials for DA), FRA A 1101 (Special Reference and Source Materials for DA), RUS A 0491 (Special Reference and Source Material for Destructive Analyses) and USA A 1496 (Traceability of DA measurements - provision of NBL certified reference materials), respectively:

- EC-JRC Geel
- Commission d'Établissement des Méthodes d'Analyse (CETAMA), France
- KRI, Russia
- USDOE New Brunswick Laboratory (NBL), USA

In addition, MSSP task UK C 1742 (Implementation Support to Nuclear Material Lab) serves as a vehicle for the provision of reference materials from the UK National Physical Laboratory (NPL).

In collaboration with these laboratories, and the wider community of the NWAL, the Agency seeks to prioritize the production of specific reference materials; often to meet urgent needs associated with the effective implementation of safeguards by the IAEA. It is of paramount importance that these capabilities, to provide and distribute specialized reference materials, are maintained.

In the area of environmental sample analysis, the highest priority is assigned to the sustainable provision of appropriate reference materials for particle analysis. The Forschungszentrum Jülich (FZJ) in Germany has demonstrated major technical achievements in the production of mono-disperse uranium particles, and its qualification for membership of the NWAL is nearing completion through MSSP task GER A 1960 (Qualification of a Lab for the IAEA Network of Analytical Labs (NWAL) for Destructive Analysis of Nuclear Materials). Beyond this activity, the spectrum of needs for particle QC reference materials is wide and calls for further support from MSSPs. New projects have been launched at other laboratories in the Member States, with a view to diversified secure and sustainable production and characterisation of QC materials using various production techniques. These developments are managed under project SGAS-002 through MSSP tasks GER A 1961 (Production of Particle Reference Materials), USA A 2370 (Production of Particle Reference and Quality Control Materials) and task proposal 18/ESL-002 (Production of Particle Reference and Quality Control Materials); these activities may result in additional laboratories qualifying to join the NWAL within the category of reference materials providers.

In 2019, the IAEA successfully completed a second campaign of in-house production and characterisation of a set of environmental QC swipes. This involved the mixing of particle QC materials and their deposition onto blank swipes, using temporary laboratory space within the ESL. The QC swipes were distributed to NWAL laboratories as part of a 2019 inter-laboratory comparison of ES particle analysis performance. External consultants have emphasized the importance that the Agency retains the capacity to mix particle QC materials in-house, to provide independent test samples to assess and demonstrate the performance of the NWAL. Efforts are ongoing to secure permanent in-house laboratory space dedicated to the sustainable production of QC swipes, supported by MSSP contributions.

In support of the NML, there is a continuing need for assistance to the production of uranium-plutonium large-size dried (LSD) spikes, used in the determination of uranium and plutonium content

by mass spectrometry. There is also a need for new reference materials to meet evolving safeguards requirements:

- Reference materials for trace element or minor isotope characterisation of uranium
- Reference materials for material age-dating techniques
- Heavy water reference materials

To assess and demonstrate the quality of analytical results, particularly when considering the international context of nuclear safeguards, it is desirable that laboratories within the NWAL are subjected to external assessment of performance. Some laboratory proficiency testing and inter-comparison programmes are well-established. MSSP tasks EC A 0267 and FRA A 1100 (Analytical Quality Control Services), Analytical Quality Control Services, focus on proficiency testing primarily through the distribution of certified reference materials from the EC-JRC (Geel) and CETAMA, respectively. The JRC administers the Nuclear Signatures Inter-laboratory Measurement Evaluation Programme (NUSIMEP) and the Regular European Inter-laboratory Measurement Evaluation Programme (REIMEP), which focus on proficiency testing of environmental and bulk nuclear material/accountancy samples, respectively. CETAMA utilizes various materials, within the Étude de la Qualité des Résultats d'Analyse dans l'Industrie Nucléaire (EQRAIN) programme, for the assessment of uranium, plutonium and impurity measurements. The ESL and NML participate in appropriate proficiency testing administered by these two laboratories. In addition, MSSP tasks USA A 1497 (Analytical Quality Control - Participation of SAL in NBL SME Programme) facilitates participation of the Agency's laboratories in the Safeguards Measurement Evaluation (SME) programme of NBL and RUS A 1514 (External Quality Control of Analytical Services) enables participation of Russian laboratories in external QC exercises for nuclear material and environmental sample analysis.

To complement these external schemes, SGAS designs and conducts and/or evaluates its own inter-laboratory comparisons across the NWAL, in cooperation with SGIM. Five such inter-laboratory comparison exercises commenced and/or were completed during the previous biennium, in the areas of:

- Destructive analysis of nuclear material (2019 Nuclear Material Inter-laboratory comparison)
- Bulk analysis of environmental samples (*IAEA 2017 ES bulk analysis inter-laboratory comparison* and the *2018 inter-laboratory comparison for ES bulk analysis*, sponsored by the United States of America Department of Energy)
- High resolution gamma spectrometry (IAEA 2017 high resolution gamma spectrometry proficiency test)
- Particle analysis of environmental samples (2019 ES particle analysis inter-laboratory comparison)

Results from these exercises were discussed with participating laboratories during Technical Meetings, and recommendations were made that the IAEA regularly repeat such exercises. The IAEA will continue to pursue this objective, and it intends to fully establish and sustain proficiency testing schemes following international standards and seeking to cover all analytical techniques of safeguards significance.

The frequency of inter-laboratory comparison exercises is also discussed at the Technical Meetings, taking into account current Agency priorities and the availability of resources. For example, organization of a first IAEA inter-laboratory comparison exercise on particle characterisation by scanning electron microscope/energy dispersive x-ray spectroscopy (SEM/EDX) is currently under consideration. Meanwhile, in the area of impurity analysis, the most recent inter-laboratory comparison was completed in 2016 and preparation of a new exercise will be considered. In addition, a request for a Cost Free Expert may be initiated in 2020, to strengthen the resources available for quality control of NWAL analytical results from ES inspection samples, coordinating with the Agency's Nuclear Fuel Cycle Analysts.

Expected outcome #3

Enhanced operational efficiency of safeguards analytical services through maintained and upgraded Safeguards Analytical Laboratory Information Management System (SALIMS).

Supporting Priority Objective: T.2

Key Outputs

Expected Completion Date

Key Outputs	Expected Completion Date
Re-engineering of Mass Spectrometry Data Evaluation System (MSDES).	August 2020

Re-engineering of the NWAL Coordination application (Phase 1, December 2021 core functionalities deployed).

Plans for accomplishing the expected outcome

The progressive upgrade of the Safeguards Analytical Laboratory Information Management System (SALIMS) will continue in 2020–2021, supported by a combination of internal resources and MSSP support (MSSP task USA D 2353 (SALIMS v1.1 Development Project / Software Development Support: LIMS for the SAL)). Building upon its existing IT architecture and recent successful achievements with the development of the NML and ESL Laboratory Information Management Systems (LIMS), during this biennium SGAS intends to:

- Address high-priority laboratory-specific development needs, further strengthen the NML and ESL LIMS and enhance their operational functionalities.
- Harmonize and consolidate internal QC monitoring.
- Re-engineer the NWAL coordination application.
- Streamline and integrate business processes and systems.

SGAS has called upon MSSPs to assist with both MSDES and NWAL coordination applications. In parallel, those maintenance and development activities that require in-depth business knowledge will be progressed using internal resources, when available. Achievements and priorities will be regularly reviewed and assessed by the SGAS IT Project Board and coordinated with project SGIS-003: Safeguards Information Systems and System Usability.

Expected outcome #4

Increased capacity for the safe and secure shipment of nuclear material samples and analytical residues.

Supporting Priority Objective: T.2

Key Outputs

Expected Completion Date

Provision of Type B Shipping Containers for shipment of large U and Pu samples. December 2021

Plans for accomplishing the expected outcome

The shipment of samples that contain larger quantities of uranium and/or plutonium requires specialized containers. These containers are certified by the Competent Authority of the country of manufacture (in other words, the national nuclear regulatory body). 'Type B' containers are highly specialized items of equipment, designed to safely contain radioactive and fissile material during routine and accident conditions of transport. Due to the effort required to design, manufacture, assemble, test, inspect and obtain certification for these containers, their cost is significant.

Due to the expiration of certificates and evolution of international shipment regulations, the IAEA's stock of containers suitable for shipment of Type B quantities of uranium and plutonium has been reduced to a single package design. Therefore, in 2019, the IAEA initiated a formal procurement process to identify potential vendors of new Type B containers suitable for safeguards purposes. The Agency will require Member States support for the provision of a modest number of new Type B shipping containers, to ensure that the Department is equipped to make 'Type B shipments' over the coming decade and thus sustain current sampling practices to support its inspection activities.

5. In-house development tasks

The table below lists internal development activities that will continue, but which will benefit from external contributions to the project. It gives an understanding of how external stakeholders can:

- Complement existing work
- Initiate activities in under-served areas of need
- Avoid duplicate activities

Expected outcome	Task #	Task (Agency's cross reference)	Title task	Description	Expected Completion Date
2	1	IAEA NM inter-laboratory comparison	inter-	Inter-laboratory exercise to evaluate the analytical capabilities and performance of the NWAL	September 2021, subject to availability of resources.

		exercise (2020.04)	laboratories with regard to NMA sample analysis.	
2	2	IAEA impurity inter-laboratory comparison exercise (2020.04)	Inter-laboratory exercise to evaluate the analytical capabilities and performance of the NWAL laboratories with regard to impurity analysis of safeguards samples.	December 2021, subject to availability of resources.
2	3	IAEA gamma spectrometry inter-laboratory comparison exercise (2020.04)	Inter-laboratory exercise to evaluate the analytical capabilities and performance of the NWAL laboratories with regard to gamma spectrometry analysis of safeguards samples.	December 2020, subject to availability of resources.
2	4	IAEA ES bulk analysis inter-laboratory comparison exercise (2020.04)	Inter-laboratory exercise to evaluate the analytical capabilities and performance of the NWAL laboratories with regard to ES bulk analysis of safeguards environmental samples.	December 2020
2	5	IAEA SEM/EDX inter-laboratory comparison exercise (2020.04)	Inter-laboratory exercise to evaluate the analytical capabilities and performance of the laboratories with regard to particle characterisation by scanning electron microscope/energy dispersive x-ray spectroscopy (SEM/EDX).	December 2021
2	6	IAEA ES particle analysis inter-laboratory comparison exercise (2020.04)	Inter-laboratory exercise to evaluate the analytical capabilities and performance of the NWAL laboratories with regard to ES particle analysis of safeguards environmental samples.	December 2021
3	7	Continuous upgrade of SGAS Laboratory Information Management Systems (2020.04)	Further integration of SGAS IT systems and streamlining of SGAS processes in a coherent and sustainable fashion, across all safeguards analytical laboratories. Strengthening of the NML and ESL LIMS and continuous enhancement of their operational functionalities; harmonization and consolidation of internal QC monitoring; re-engineering of the NWAL coordination application.	December 2021

6. Attachments

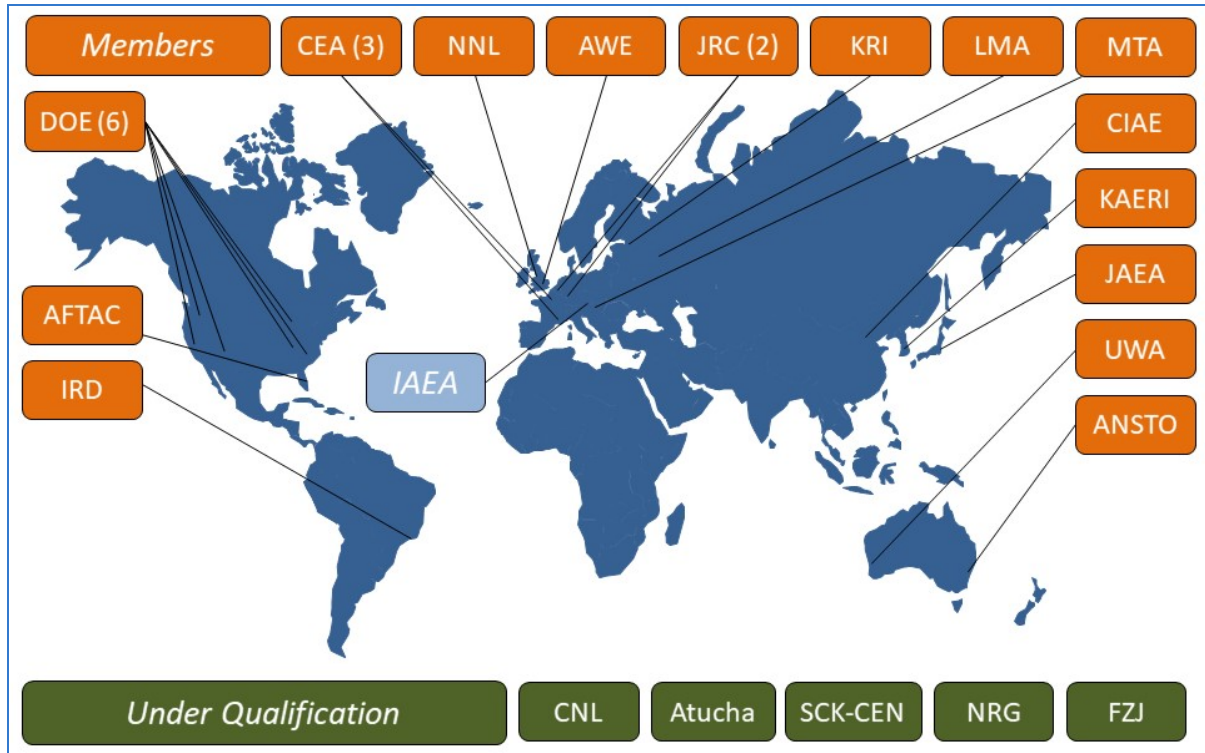

Figure 12: IAEA Network of Analytical Laboratories



Figure 13: IAEA Technical Meeting on the 2019 Nuclear Material Round Robin

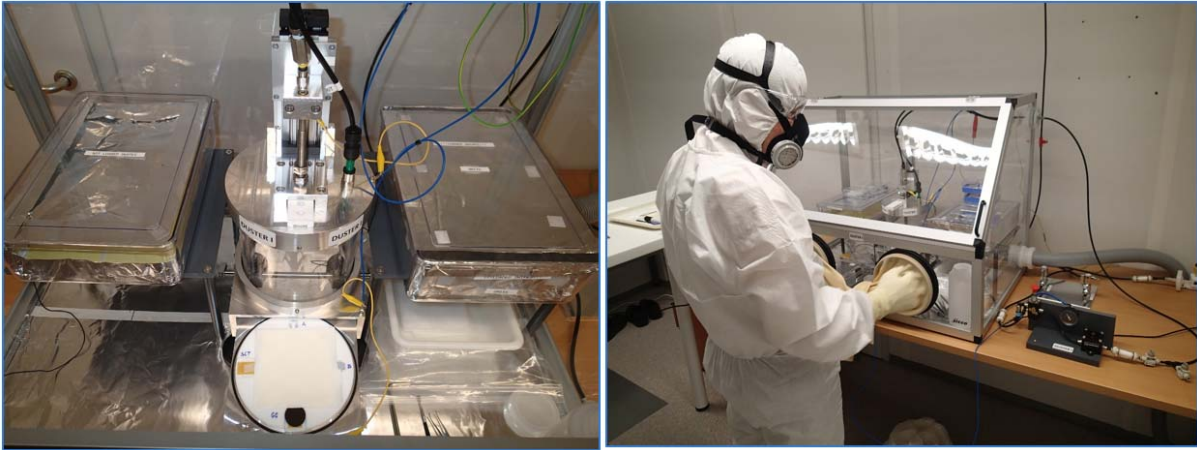

Figure 14: Equipment used for the in-house production of a set of environmental QC swipes, distributed to NWAL laboratories for the 2019 inter-laboratory comparison on ES particle analysis

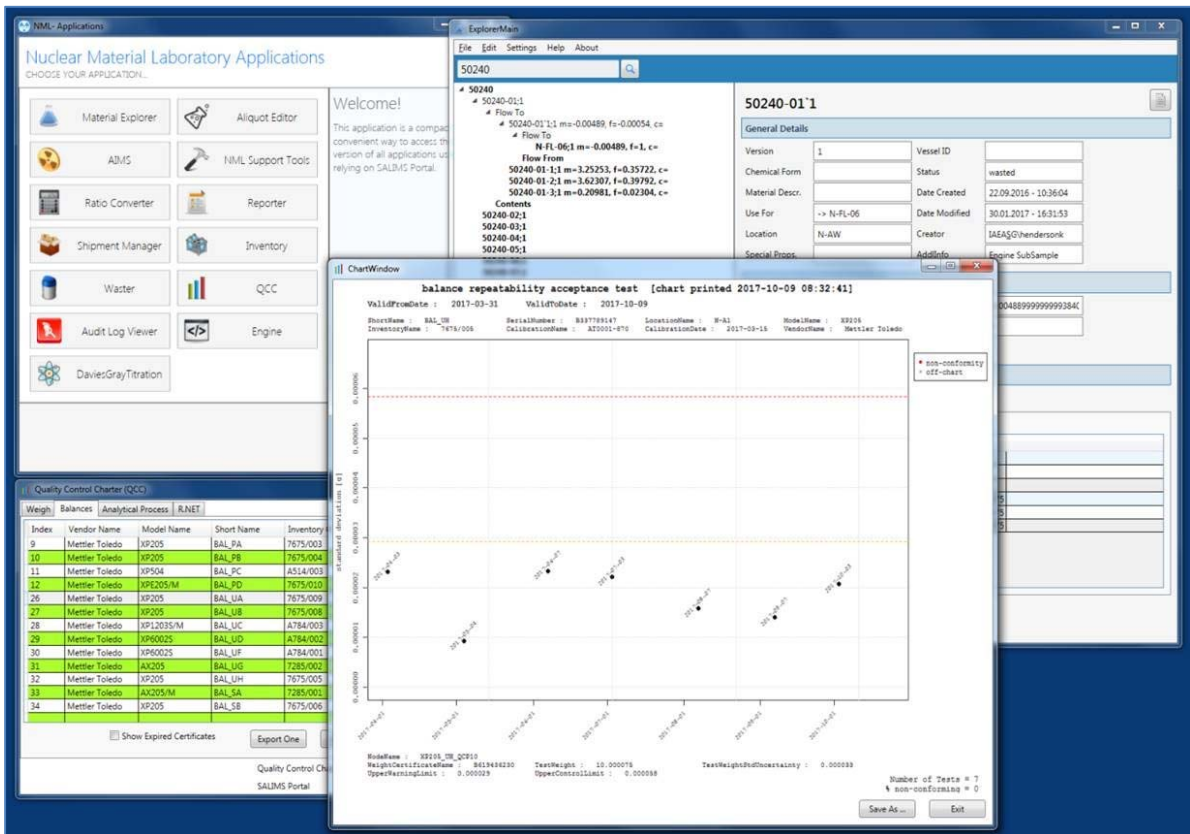

Figure 15: Screenshot of Mass Spectrometry Data Evaluation System (MSDES)

SGCP-003: Safeguards Approaches

Project Manager: Jay DOO

1. Overview

This chapter describes the plans for developing and implementing safeguards concepts and State-level safeguards approaches for the 2020–2021 biennium.

Project objective

The overall objective is to develop, demonstrate and implement innovative and effective concepts and approaches to meet safeguards challenges.

Foreseen challenges

Foreseen challenges for this project over the next decade include:

- Full alignment of internal methodologies, procedures and guidelines to further enhance the consistency of safeguards implementation at the State level.
- New types and increasing numbers of nuclear facilities that require early adoption of safeguards by design.
- An increasing number of nuclear facilities to be decommissioned, for which the implementation of efficient and effective safeguards during the decommissioning phase needs to be addressed.
- Emerging nuclear fuel cycle technologies, requiring new safeguards concepts and approaches.

Top project priorities in 2020–2021

- Develop methodologies and guidance to standardize and improve the internal processes for conducting acquisition path analysis, developing State-level safeguards approaches (SLAs) and evaluating the effectiveness of safeguards implementation.
- Develop effective and efficient safeguards concepts early in the design process of new types of facilities including Small Modular Reactors (SMRs).
- Develop safeguards implementation guidelines for facilities under decommissioning and safeguards concepts for post-accident facilities under decommissioning.

2. Strategy framework linkages

IAEA's Programme and Budget project linkage

The plan and MSSP tasks detailed in this chapter are followed-up and/or coordinated by Agency staff and are aligned with the objectives of the Agency's project 4.1.1.002 Safeguards approaches and concepts in the *Agency's Programme and Budget 2020–2021*.

Safeguards Research & Development Plan linkage

Priority Objective	R&D Needs
P.3 Monitor, assess and prepare for evolving nuclear proliferation challenges	P.3.R1 Maintain awareness of changes in the nuclear landscape and associated proliferation risks, including the impact of non-State actors on the safeguards system.
P.5 Prepare for new types of facilities and decommissioning	P.5.R1 Address identified gaps in facility-specific guidance, training and tools for conducting verification activities during decommissioning.
	P.5.R2 Based on the prospects and timing for emerging nuclear fuel cycle facilities (e.g., pyroprocessing plants, geological repositories) develop and deploy as appropriate: <ul style="list-style-type: none">• safeguards concepts• tools• techniques• training

S.3	Advance safeguards-by-design	S.3.R1	Identify and pursue opportunities for the Agency and Member States to promote the early consideration of safeguards among the nuclear industry.
V.2	Reinforce State evaluation	V.2.R1	Develop a set of reference materials to assist SEGs in the assessment of a State's capability to accomplish acquisition path steps, which take into account the level of maturity of the State's nuclear fuel cycle and associated technical capabilities.

3. Progress on expected outcomes, key outputs and tasks from the previous biennium

Expected Outcome #1 from the 2018–2019 Biennium

Improved ability to fully implement the State Level Concept through the development of internal guidance documents and additional tools for the development of State-level safeguards approaches.

Supporting R&D Need: V.2.R1

Key Outputs	Status	Comments
Methodology and guidance for assessing acquisition path steps, including a State's technical capability to develop nuclear fuel cycle technologies and facilities as well as nuclear material diversion and facility misuse scenarios	Key output achieved; work continues	Details of nuclear fuel cycle technologies were identified as sub-tasks. As the first sub-task, gas centrifuge technologies were assessed. Based on experience gained, work is continuing on further nuclear fuel cycle technologies.

Expected Outcome #2 from the 2018–2019 Biennium

Increased ability to detect undeclared nuclear material and activities through update and improvement of the 'Physical Model'.

Supporting R&D Need: P.3.R1

Key Outputs	Status	Comments
Updated Physical Model (all volumes)	Key output achieved; work continues	All Physical Model volumes were reviewed and updated. Final review and editing continue.

Expected Outcome #3 from the 2018–2019 Biennium

Enhanced ability to safeguard new types of facilities through development of safeguards concepts for pyro-processing plants and small modular and/or Gen IV reactors.

Supporting R&D Need: P.5.R2

Key Outputs	Status	Comments
Safeguards Technical Report on safeguards concepts and supporting measures for a pyro-processing facility	Key output achieved; work continues	A Safeguards Technical Report on safeguards concepts and supporting measures for a pyro-processing facility was drafted. Final review and editing continues.
Safeguards concepts and supporting measures for a High Temperature Gas Cooled Reactor Pebble Modules (HTR-PM) plant	Delayed; work in progress	The Department and State experts (authorities, designers and facility operators) held meetings to review the HTR-PM design and assess the application of safeguards. Sub-tasks were identified, to address the application of safeguards within the HTR-PM design. The task continues.

Expected Outcome #4 from the 2018–2019 Biennium

Enhanced ability to safeguard new types of facilities through development of safeguards by design guidance documents.

Supporting R&D Need: S.3.R1

Key Outputs	Status	Comments
Three Safeguards by Design (SBD) guidance documents on International Safeguards in the Design of Facilities for Long Term Spent Fuel Management, International Safeguards in the Design of Reprocessing Plants and International Safeguards in the Design of Enrichment Plants	Delayed; nearing completion	NF-T-3.1, International Safeguards in the Design of Facilities for Long Term Spent Fuel Management, was published in 2018. Final review is in progress for International Safeguards in the Design of Reprocessing Plants and International Safeguards in the Design of Enrichment Plants.
Use of the industry standardized UF ₆ cylinder identifier	Key output achieved; work completed	Completed.

Expected Outcome #5 from the 2018–2019 Biennium

Improved ability to verify facilities under the decommissioning phase through the development of Safeguards implementation guidelines and concepts.

Supporting R&D Need: P.5.R1

Key Outputs	Status	Comments
Safeguards implementation guidelines for facilities under decommissioning	Key output achieved; work continues	Design Information Questionnaire (DIQ) templates were updated to incorporate information on facilities under decommissioning. Safeguards guidelines for facilities under decommissioning were drafted and have been reviewed.
Specific safeguards concepts for post-accident facilities under decommissioning based on lessons learned from Fukushima Dai-ichi and Chernobyl	Delayed; work in progress	The first consultancy meeting with Member States will be held in 2020 to develop safeguards guidelines for post-accident facilities.

4. Expected outcomes, key outputs and tasks for the 2020–2021 biennium

In order to achieve overall objectives and meet R&D needs, tasks must be initiated, continued and/or finalized during the 2020–2021 biennium. The following expected outcomes serve as an outline for the next 2 years.

Expected outcome #1	
Improved ability to fully implement the State Level Concept through the development of internal guidance documents and additional tools for the development of State Level Approaches. Supporting R&D Need: V.2.R1	
Key Outputs	Expected Completion Date
Methodology and guidance for assessing acquisition path steps, including a State's technical capability to develop nuclear fuel cycle technologies and facilities as well as nuclear material diversion and facility misuse scenarios.	December 2021
MSSP consultancy meetings on guidance for assessing steps involving undeclared facilities during acquisition path analysis:	December 2020
Reprocessing and hot cell technologies.	March 2020
Reactor technologies (graphite/heavy water/light water moderated reactor types).	June 2020
Fuel fabrication technologies.	September 2020
Conversion technologies (HEU & Pu metal).	December 2020
Completion of detailed technical guidance reports for assessing steps involving undeclared facilities during acquisition path analysis: To be determined on the basis of experiences gained in 2020. The consultancy meetings for the remaining NFC steps (sub-tasks) will continue in 2021.	December 2021

Plans for accomplishing the expected outcome

Based on experience gained in developing and updating State Level Approaches (SLAs), new methodologies and guidance documents will be developed during 2020–2021 to support acquisition path analysis, development of SLAs and evaluation of the effectiveness of safeguards implementation. One ongoing task is the assessment of acquisition path steps within an APA under the SLA project. These will include consideration of a State's technical capability to develop nuclear fuel cycle technologies and facilities, as well as nuclear material diversion and facility misuse scenarios. MSSP support will be required within the framework of MSSP tasks GER C 2245, EC C 2305, CAN C 2238, SWE C 2218, CZ C 2224, FIN C 2399, AUL C 2335, UK C 2268, BRZ C 2311, NET C 2454, JPN C 2230, USA C 2241, BEL C 2277, FRA C 2261 and HUN C 2236 (Umbrella Task - Technical Assistance on Methodology and Guidance for Implementation of Safeguards at the State level).

Based on experience gained, further Member State assistance may be requested to support the development of methodologies and guidance for conducting acquisition path analysis, developing and implementing SLAs and evaluating the effectiveness of safeguards implementation.

Expected outcome #2	
Increased ability to detect undeclared nuclear material and activities through update and improvement of the 'Physical Model'. Supporting R&D Need: P.3.R1	
Key Outputs	Expected Completion Date
Updated Physical Model (all volumes)	June 2021
Volume 1 (Mining and ore processing)	June 2020
Volume 2 (Conversion)	March 2020
Volume 3 (Uranium enrichment)	September 2020
Volume 5 (Fuel fabrication)	September 2020

Volume 6 (Reactor and neutron sources)	December 2020
Volume 7 (Heavy water)	September 2020
Volume 8 (Reprocessing and recycling of spent fuel)	March 2021
Volume 9 (Spent fuel management)	March 2020
Volume 10 (Radioactive waste)	September 2020
Volume 11 (Hot cells)	September 2020

Plans for accomplishing the expected outcome

The Physical Model (PM) serves as a technical resource for departmental staff members involved in safeguards activities such as State evaluation, acquisition path analysis and State Level Approach development and training. The PM needs to be updated to ensure that the lists of signatures and indicators of nuclear fuel cycle activities are complete and that the weighting of the indicators is accurate with respect to any evolution in fuel cycle technology. The PM should be organized and accessible in such a way that it facilitates analysis by State Evaluation Groups. Meetings with experts from MSSPs may be continued to improve the PM's completeness and usability.

Expected outcome #3

Enhanced ability to safeguard new types of facilities through development of safeguards concepts and approaches for pyro-processing plants and small modular and/or Gen IV reactors. **Supporting R&D Needs:** P.5.R2 and S.3.R1

Key Outputs	Expected Completion Date
Model safeguards approaches for new types of facilities.	December 2021
Model safeguards approach for a pyroprocessing plant.	December 2020
Model safeguards approach for a transportable (floating) nuclear power plant (KLT-40S).	September 2021
Model safeguards approach for a pebble-bed modular reactor (HTR-PM).	December 2021
Model safeguards approach for a passive small modular pressurized light water reactor (SMART: System-integrated modular advanced reactor).	December 2021
Model safeguards approaches for new types of small modular reactors to be determined by States.	December 2021

Plans for accomplishing the expected outcome

The IAEA will require support under several continuing or proposed MSSP tasks.

Following the provision of a draft model safeguards approach for a pyroprocessing plant, delivered to the IAEA in July 2019 through MSSP task ROK C 2263 (Development of Safeguards Measures and Equipment for a Pyroprocessing Plant using Related Facilities (PRIDE, ACPF and DDFD) in ROK), details of safeguards measures have been reviewed in the IAEA. This is expected to result in further work in the 2020–2021 biennium. The IAEA has also reviewed various specific safeguards subjects, including DA sampling identified between the ROK and the USA under joint MSSP tasks JNT C 1953 ROK and USA (Trilateral Safeguards and Security Working Group (SSWG) under the USA/ROK Joint Fuel Cycle Study (JFCS)). This is expected to result in further work in the 2020–2021 biennium.

The IAEA plans to organize a consultancy meeting for 2020 to proceed with contributions to a Safeguards Technical Report on Pyroprocessing under MSSP tasks FRA C 1943, JPN C 1962 and ROK C 1885 (Contribution to a Safeguards Technical Report on Pyroprocessing).

Implementation of safeguards by design principles will be considered under sub-tasks to be applied to the HTR-PM design (MSSP task CPR C 2429 (Development of Safeguards Measures for the HTR-PM Plant in China)).

A further four tasks will consider aspects of safeguards associated with SMRs, involving a number of technical meetings. These will include:

- A technical meeting with SMR (KLT-40S) designers, to review details of information on DIQ and to carry out a technical visit to review the possible application of safeguards measures

at KLT-40S through MSSP task RUS C 2400 (Safeguards by Design for Small Modular Reactors).

- A technical meeting with SMR (SMART) designers to review details of information on DIQ and possible application of safeguards measures at SMART through MSSP task ROK C 2426 (Safeguards by Design for Small Modular Reactors).
- Technical meetings with additional SMRs designers to explain concepts of safeguards by design and to review details of information on DIQ and possible application of safeguards measures at SMRs under MSSP tasks CAN C 2432 and USA C 2418 (Safeguards by design for small modular reactors).

A MSSP task proposal (Consultants: Experts in emerging nuclear technologies or new types of facilities) will be initiated to address new nuclear fuel cycle technologies and develop new safeguards concepts.

Expected outcome #4	
Improved ability to verify facilities under the decommissioning phase through the development of safeguards implementation guidelines and concepts.	
Supporting R&D Need: P.5.R1	
Key Outputs	Expected Completion Date
Updated DIQ templates and safeguards guidelines to incorporate post-operation information at facilities under decommissioning.	December 2021
Updated DIQ templates for all types of facilities to incorporate post-operation information at facilities under decommissioning.	March 2020
DIQ completion guidelines and DIQ examples.	June 2020
Safeguards guidelines for facilities under decommissioning.	September 2020
Safeguards guidelines for post-accident facilities.	June 2021

Plans for accomplishing the expected outcome

A CFE position has been established (MSSP task JPN C 2274 (Expert - Safeguards Analyst (Approaches))), and it will continue with the goal of updating the DIQ template and developing safeguards implementation guidelines for facilities under decommissioning. In addition, specific safeguards concepts for post-accident facilities under decommissioning will be developed.

Expert group meetings—under MSSP tasks JNT C 2365 BEL, 2366 CZ, 2367 JPN, 2371 GER, 2381 ROK, 2382 RSA, 2388 EC, 2403 USA, 2415 FIN and 2430 CAN (Development of Safeguards Guideline for Facilities Under Decommissioning and Post-Accident Facilities)—will be continued, to develop safeguards guidelines for incorporation of post-operation information at facilities under decommissioning and post-accident facilities.

5. Attachments

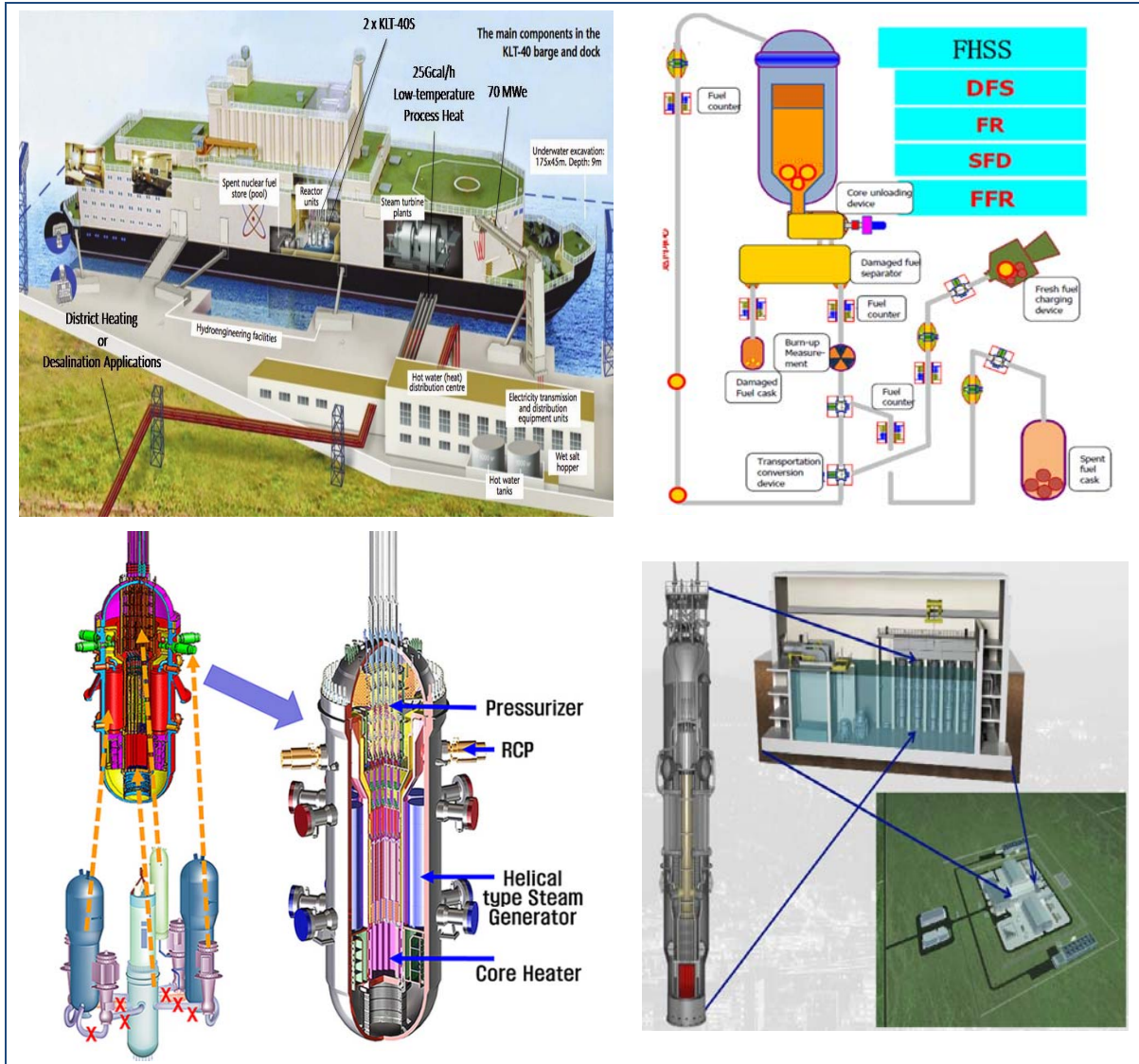

Figure 16: New types of Small Modular Reactors (SMRs).



Figure 17: Consultancy Meeting with MSSPs for Safeguards Guidelines for Facilities under Decommissioning.

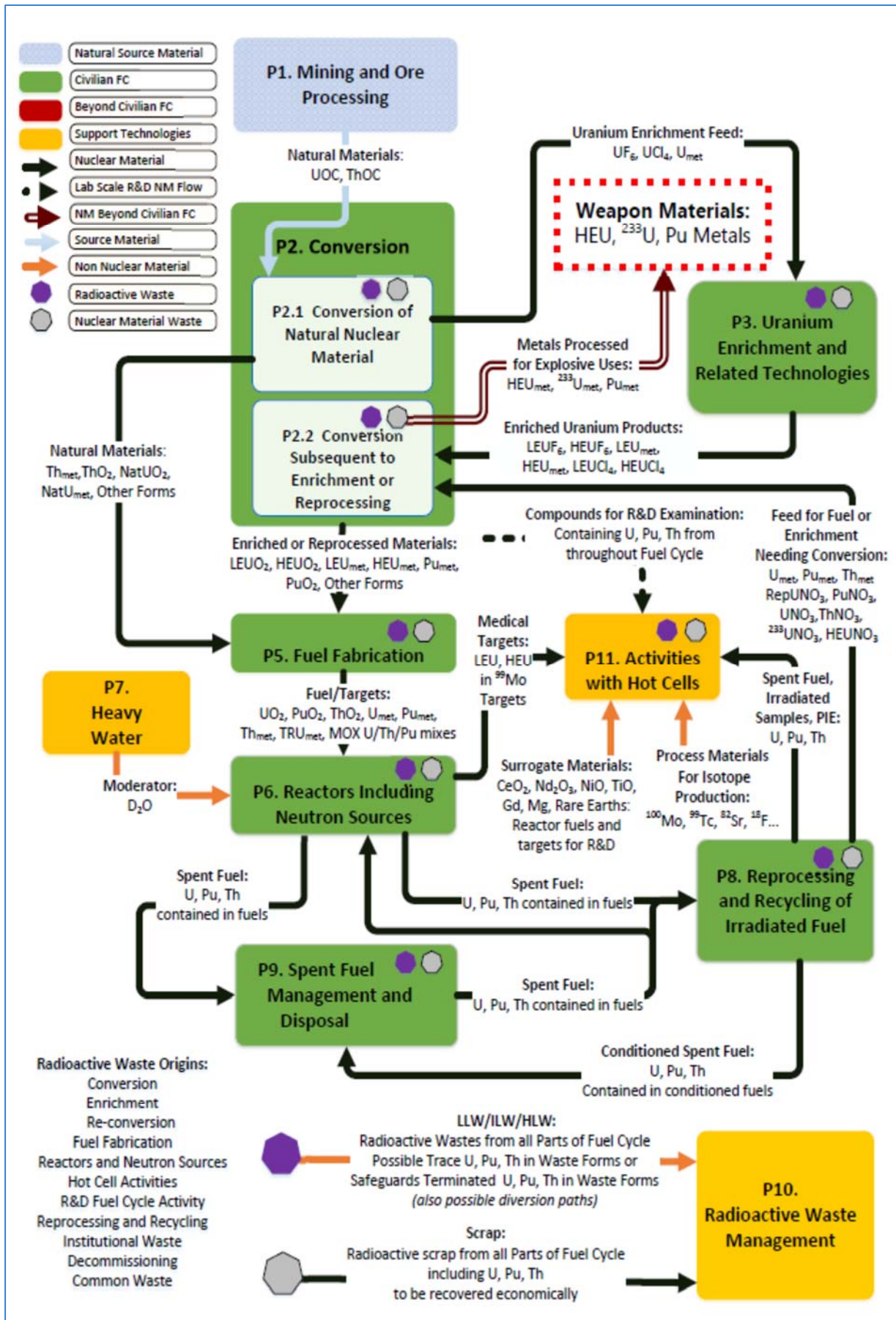

Figure 18: Physical Model flow diagram

SGCP-004: Strategic Planning and Partnerships

Project Manager: Eric PUJOL

1. Overview

This chapter describes the plans for managing strategic planning-related processes—from foresight and the analysis of associated challenges and opportunities to strategy formulation and execution—and enhancing external partnerships that are increasingly important for successful implementation of the Agency’s nuclear verification programme for the 2020–2021 biennium and beyond.

Project objective

The overall project objective is to ensure effective strategic planning and execution, ensure mobilization of partnerships and optimal coordination of Member States’ and other stakeholders’ support and to enhance safeguards effectiveness and organizational performance in line with results-based management as described in the *Agency’s Medium Term Strategy 2018–2023*.

Foreseen challenges

Resource constraints directly impact upon delivery capabilities. New and growing challenges in core verification implementation continue to increase the workload of the Department, while resources remain largely static. To ensure that the Agency can continue to fulfill its legal obligations under safeguards agreements, optimum use must be made of existing and potential new sources of resource to address safeguards priorities.

Top project priorities in 2020–2021

- Develop processes, methods and tools to strengthen foresight, enabling changes in the operating environment to be identified, monitored, analysed and addressed at an early stage.
- Further institutionalize existing processes, methods and tools for executing the Department’s strategic plan, to ensure their sustainability.
- Mobilize traditional and non-traditional partnerships and further align their support to address safeguards priorities.

2. Strategy framework linkages

IAEA’s Programme and Budget project linkage

The plan and MSSP tasks detailed in this chapter are followed-up and/or coordinated by Agency staff and are aligned with the objectives of the Agency’s project #4.1.1.001 Strategic planning and coordination in the *Agency’s Programme and Budget 2020–2021*.

Safeguards Research & Development Plan linkage

Priority Objective	R&D Needs
C.1 Strengthen management processes	C.1.R1 Develop effective and sustainable strategic management processes to enable effective horizontal and vertical strategy execution.
P.3 Monitor, assess and prepare for evolving nuclear proliferation challenges	P.3.R1 Maintain awareness of changes in the nuclear landscape and associated proliferation risks, including the impact of non-State actors on the safeguards system.

Collaborating D&IS projects

- SGCP-101: Quality Management
- SGIS-003: Safeguards Information Systems and System Usability
- SGTS-008: Instrumentation Technology Foresight

3. Progress on expected outcomes, key outputs and tasks from the previous biennium

Expected Outcome #1 from the 2018–2019 Biennium		
Strengthened tools, methods and processes for executing the Department's strategic plan. Supporting R&D Need: C.1.R1		
Key Outputs	Status	Comments
Development of processes and tools to support strategy implementation, monitoring and reporting (including the alignment of Key Performance Indicators (KPIs), in collaboration with SGCP-101)	Key output achieved; work continues	Processes and tools have been developed; work continues, as the Department provides feedback and adjusts as needed to ensure full integration of the processes. Integration of KPIs into the Strategy Portal is not complete and depends on the progress of the Departmental KPI project.
Update of the Strategy Portal to support implementation, monitoring and reporting (including the alignment of KPIs, in collaboration with SGCP-101)	Key output achieved; work continues	The Strategy Portal was developed and launched; it is in use by the Department for supporting, monitoring and reporting on strategy execution. The 2019 development roadmap is completed. The 2020 development roadmap includes further modifications based on user feedback and maintenance including integration of Departmental Key Performance Indicators (KPIs).

Expected Outcome #2 from the 2018–2019 Biennium		
Improved organisational ability to identify and adjust to changes in the operating environment in a flexible and timely manner. Supporting R&D Need: P.3.R1		
Key Outputs	Status	Comments
Organization of and report on the Emerging Technologies Workshop (ETW) 2019	Delayed; work in progress	The ETW is rescheduled for early 2020.
Organization of a Scenario Development Workshop	Cancelled	Event cancelled, given other demands on Department resources.
Organization of and report on exchanges with foresight practitioners (in collaboration with SGTS-008)	Key output achieved; work continues	The Strategic Planning Team Leader participated in the 2018 meeting of the UN Strategic Planning Network and delivered a presentation on scenario planning.
Report on the review of the Operating Environment	Delayed; nearing completion	Report to be completed in Spring 2020 in order to leverage input from Emerging Technologies Workshop scheduled for January 2020.
Organization of an Annual Strategy Workshop considering plan implementation monitoring, updating scenarios, operating environment, adjusting strategic priorities	Key output achieved; work completed	A strategy workshop was held in October 2018 for the Department's senior management team, resulting in further prioritization of Strategic Plan implementation actions.

Expected Outcome #3 from the 2018–2019 Biennium

Enhanced stakeholder awareness and understanding of safeguards and nuclear verification.

Supporting Priority Objectives: S.1 and S.4

Key Outputs	Status	Comments
Organization of a Symposium on International Safeguards, "Building Future Safeguards Capabilities"	Key output achieved; work completed	The Symposium was held 5–8 November 2018 at IAEA HQ. Around 800 people from 90 States attended. The event had the greatest geographical and gender balance to date.
Report/proceedings of, and action plan resulting from the Symposium	Key output achieved; work completed	The Symposium Report was published in July 2019 as STR-392. The report summarizes the key 'takeaways' and contains seven sets of 'Ideas for Action' for the safeguards community at large (in other words, not limited to actions for the Department).

Expected Outcome #4 from the 2018–2019 Biennium

Optimized use of MSSP support through alignment of tasks with strategic objectives and close coordination with MSSPs.

Supporting Priority Objectives: S.4 and C.4

Key Outputs	Status	Comments
External release of updated R&D Plan (STR-385)	Key output achieved; work completed	Released as STR-385 in January 2018.
Upgraded SPRICS (in collaboration with SGIS-003)	Key output achieved; work continues	A functional version of SPRICS was released in June 2018; revised Support Programme task proposal (SP-1) templates were released in October 2018. Further improvements, such as online status updates, are in progress.
Summary reports of annual or bi-annual bilateral meetings with MSSPs	Key output achieved; work completed	Fifty annual or semi-annual Member State Support Programme review meetings were coordinated and relevant summary reports were issued.
List comparing needs from R&D Plan (STR-385) with actual current and planned partner activities (compiled with assistance from MSSPs and other partner organizations)	Delayed; nearing completion	Release planned for early 2020.

4. Expected outcomes, key outputs and tasks for the 2020–2021 biennium

In order to achieve overall objectives and meet R&D needs, tasks must be initiated, continued and/or finalized during the 2020–2021 biennium. The following expected outcomes serve as an outline for the next 2 years.

Expected outcome #1	
Support to MSSP coordination and effective administration to address the R&D needs of the Department.	
Supporting Priority Objectives: S.4 and C.3	
Key Outputs	Expected Completion Date
SPRICS-hosted database of R&D needs and progress, to enable the system with visualizing capabilities of how R&D needs are being met by MSSP tasks.	December 2020
Ability for SPRICS users to view status report and action history for the previous 2 years (as a first step) of active tasks on task summary pages (with an intention to add more historical data in future biennium plans).	December 2020
SPRICS-generated agendas, meeting packages and summaries of decisions and agreed actions of annual and bi-annual review meetings with MSSPs.	December 2021

Plans for accomplishing the expected outcome

The success of this expected outcome will rely upon Member States support including the Japanese Support Programme, which provides a Cost Free Expert, currently MSSP task JPN F 2271 (Expert - Support Programme Administrator), and the possible recruitment of an intern or a Junior Professional Officer (JPO).

The Support Programme Coordination Team will coordinate annual and semi-annual MSSP review meetings and coordinate status updates, actions and task proposals pending MSSP decisions. In collaboration with project SGIS-003: Safeguards Information Systems and System Usability, further work will be undertaken to visualize SPRICS data and further improve usability.

Expected outcome #2	
Improved organizational ability to monitor, identify and adjust to changes in the operating environment in a timely manner.	
Supporting Priority Objective: T.5	
Supporting R&D Needs: P.3.R	
Key Outputs	Expected Completion Date
2020 Emerging Technologies Workshop.	January 2020
2020 Emerging Technologies Workshop Report.	May 2020
Explore feasibility of adapting existing Artificial Intelligence (AI)-based or automation-based capabilities to support continuous environmental scanning of the Department's operating environment.	December 2021

Plans for accomplishing the expected outcome

Environmental scanning, especially of trends and developments in technologies that could impact proliferation risks, is a key element in fostering the Department's preparedness. Anticipatory activities—including events such as Emerging Technologies Workshops (ETW), International Safeguards Symposia and the Operating Environment Analysis—facilitate organizational decision making and investments that can mitigate the risks and/or capitalize on the opportunities that emerging technologies and other changes in the safeguards environment may present. For example, the 2017 ETW directly influenced 20% of the total stated needs within the 2018 update of the R&D Plan (STR-385).

While the success of this expected outcome will primarily depend on executing the Departmental Strategic Management framework, leveraging AI for foresight efforts could provide further efficiencies and improve effectiveness. Emerging AI and automation tools, including sophisticated

web crawlers, can continuously monitor the open source environment and identify key trends and environmental changes. Obtaining such a capability would have a multiplier effect on the strategic planning function: providing for more rapid change detection of and response to key environmental changes, while also freeing up departmental staff bandwidth for other decision-supporting activities. The first step would be to assess in-house capabilities as well as the availability of commercial off-the-shelf AI tools, to avoid unnecessary development. This assessment will be conducted in close collaboration with SGIM-003 (expected outcomes 1 and 2). A task proposal for development of the AI-based horizon-scanning capability may be formulated in early 2020.

Several MSSP tasks will contribute significantly to this expected outcome. The Department currently has two JPOs supporting the 2020 ETW. The Department also has a task proposal, requesting a JPO for strategic planning support, pending MSSP decisions. A joint task requesting other resource support (for example, subject matter experts) for the 2020 ETW is currently active, and the Department welcomes further support.

Expected outcome #3	
Support to the Department's ability to fulfill its mission is augmented through vetted non-traditional partnerships.	
Supporting Priority Objectives: S.1 and S.4	
Key Outputs	Expected Completion Date
Development of a strategy for enhancing non-traditional partnerships.	December 2020
Development of a non-traditional partnerships coordination programme that facilitates contributions from vetted non-traditional partners.	December 2021
Development of partnerships with other IAEA Departments.	December 2021

Plans for accomplishing the expected outcome

A growing share of the Department's activities are supported through extrabudgetary support; the vast majority of it comes from Member State Support Programmes. The 2018 International Safeguards Symposium demonstrated that:

- There is a significant potential benefit in engaging non-traditional partners
- There is significant interest from non-traditional partners engaged in relevant activities to support the Department

Constructing a 'demand'-driven (in other words, strategy-based) partnership programme can increase extrabudgetary and in-kind support for safeguards implementation, while at the same time increasing awareness of the Agency's safeguards mission. In doing so, the IAEA non-traditional partners vetting process will be duly implemented.

In order to achieve this outcome, the Department intends to develop a strategy and design a concept for and set up a 'non-traditional partnership coordination programme' to mobilize and direct support from non-traditional partners to the Department. The development of the strategy and concept will initially be funded with extrabudgetary support, and a task proposal for a CFE will be initiated.

Internally the Department will also explore possibilities to enhance partnerships with other IAEA Departments.

Expected outcome #4	
Strategic management processes are sustainable and integrated into the Department's management systems and enable enhanced management capabilities to predict, manage, communicate, prioritize and align resources to execute Departmental strategic objectives and priorities.	
Supporting R&D Needs: C.1.R1	
Key Outputs	Expected Completion Date
Strategy Execution Application (SEA) on the Strategy Portal with integrated KPIs exists.	December 2021
Living Strategic Plan management facilitated by Strategy Portal.	December 2021
A biennial strategy implementation plan is published and in use.	December 2020

Plans for accomplishing the expected outcome

The Department will ensure a return on investment, as well as sustainability of benefits, from what has been accomplished in the last two years. The plan is to continue to use the processes, governance and strategy system and to adjust and improve them to integrate strategic management into the Department's management system and improve the Department's strategy execution capabilities.

Resources required to continue this task beyond December 2019 include a CFE with additional support/internal coordination with project SGIS-003: Safeguards Information Systems and System Usability for IT development.

5. Attachments



Figure 19: Details on the event's insights on innovation, partnering, improvements and ideas for action are available at <https://www.iaea.org/events/symposium-on-international-safeguards-2018>.



Figure 20: The IAEA Symposium on International Safeguards is a flagship event organized and hosted every four years by the IAEA for the nuclear safeguards community. As the only truly global mechanism of its kind, the Symposium provides the IAEA's partners with an opportunity to address safeguards implementation issues, showcase their research and share ideas for advancing safeguards.



Figure 21: The home page of the internal Strategy Portal 2.0 where departmental staff members manage and implement priority actions.

SGCP-101: Quality Management

Project Manager: Roy FITZGERALD

1. Overview

This chapter describes the plans for developing, implementing and enhancing processes and management tools supporting the Department's Quality Management System (QMS) for the 2020–2021 biennium.

Project objective

The overall objective is to strengthen and mature the Department's Quality Management System and monitor and report on its effectiveness.

Foreseen challenges

The most significant challenges will be acquiring and integrating software that supports process mapping, performance monitoring, document and risk management and internal auditing.

Top project priorities in 2020–2021

- Continue to improve and mature the process-based approach implemented in the Department.
- Upgrade QMS tools and techniques for improving and monitoring process performance.
- Continually assess the effectiveness of the Department's QMS and implement improvements as needed.

2. Strategy framework linkages

IAEA's Programme and Budget project linkage

The plan and MSSP tasks, detailed in this chapter, are followed-up and/or coordinated by Agency staff and are aligned with the objectives of the Agency's projects *Process design and Quality management* in the *Agency's Programme and Budget 2020–2021*.

Safeguards Research & Development Plan linkage

Priority Objective	R&D Needs
W.1 Reform human resource management	W.1.R1 Develop and maintain, through training, new expertise required by the Department, where needed, with the help of Member States.
P.1 Ensure information security	P.1.R2 Improve Information Security capabilities in areas of risk: management, auditing and reporting; vulnerability management; threat intelligence; and improve processes, procedures and standards.

Collaborating D&IS project

- SGCP-102: Training
- SGIS-003: Safeguards Information Systems and System Usability

3. Progress on expected outcomes, key outputs and tasks from the previous biennium

Expected Outcome #1 from the 2018–2019 Biennium		
Enhanced integration of quality management principles into the implementation of safeguards. Supporting R&D Needs: C.1.R1		
Key Outputs	Status	Comments
Upgraded Document Manager application to provide an enhanced and more efficient process to create, review, publish, and search for documents supporting the QMS.	Delayed; work in progress	A prototype for an enhanced application that provides a more efficient means to create, review, publish and search for QMS documents was developed. Further development is needed, in conjunction with SGIS-003.

Expected Outcome #2 from the 2018–2019 Biennium		
Developed, fully implemented and continually improved process-based approach within the management system. Supporting R&D Needs: C.1.R1		
Key Outputs	Status	Comments
Implementation of prioritized actions identified in the 2017 self-assessment on the maturity of the Department's Quality Management System.	Key output achieved; work completed	Prioritized actions, identified in the 2017 QMS self-assessment, were completed.
Support for the performance monitoring in the Department, based on the identified set of key performance indicators.	Key output achieved; work continues	A dashboard to track an initial set of performance indicators was developed and presented internally. Actions are underway to review the pilot dashboard and agree on plans for further deployment.
Enhanced e-learning courses on QMS.	Ongoing; work in progress	Some videos were created to educate departmental staff members on internal quality and document management practices.

Expected Outcome #3 from the 2018–2019 Biennium		
Improved knowledge management and retention. Supporting Priority Objective: W.3		
Key Outputs	Status	Comments
List of strategic actions and activities to enhance methods for capturing and transferring knowledge within the Department.	Key output achieved; work completed	Following an external assessment of the Department's knowledge management programme, a strategic roadmap outlining actions and activities for further enhancing the programme was created and agreed to. The Department is proceeding with the actions and activities identified as part of this plan.

Expected Outcome #4 from the 2018–2019 Biennium

Enhanced financial transparency and accountability for safeguards implementation through the continued development and refinement of the cost calculation methodology.

Supporting Priority Objective: C.4

Key Outputs

Status

Comments

Procedures and practices for further utilizing the Department's cost calculation methodology to assess the impact of implementation of process changes.

Key output achieved; work continues

Efforts continue, to further utilize the Department's cost calculation model for assessing the impact of process changes.

4. Expected outcomes, key outputs and tasks for the 2020–2021 biennium

In order to achieve overall objectives and meet R&D needs, tasks must be initiated, continued and/or finalized during the 2020–2021 biennium. The following expected outcomes serve as an outline for the next 2 years.

Expected outcome #1

Enhanced integration of quality management principles into the implementation of safeguards activities.

Supporting R&D Needs: W.1.R1 and P.1.R2

Key Outputs

Expected Completion Date

A QMS training curriculum to be followed by focused instructor-led training as part of the CTR training catalogue.

December 2021

A more formal and rigorous means for identification, management and mitigation of risk, as part of the Department's QMS.

March 2020

Plans for accomplishing the expected outcome

The QMS is a key element in the overall internal assurance framework of the Department. The QMS helps to ensure consistent implementation of safeguards processes and procedures.

A number of opportunities for improving the QMS have been identified in recent self-assessments and audits. In collaboration with project SGIS-003: Safeguards Information Systems and System Usability, efforts will be undertaken to further enhance and improve the following elements of the QMS:

- **Training and awareness:** Additional training and awareness sessions on the role of QMS and how it contributes to the sustained success of the Department, with a focus on quality management; quality control; quality assurance; causal analysis and information management.
- **Risk management:** Further integration and definition of risk management practices and processes as part of the QMS.
- **Performance monitoring:** Supporting process owners in establishing and monitoring process performance metrics and measurements.

Three MSSP tasks remain open to support these efforts: Task JNT B 1277 USA (Workshop on Quality Assurance Techniques), which provides the means for further support for training and awareness considered necessary to support the effective implementation of the QMS and CAN C 1978 and UK C 2005 (Performance Indicators Support), which supports the development and implementation of performance indicators. Additional support may be requested for support in developing practices and process performance monitoring.

Expected outcome #2

Improved process governance and an enhanced process framework, to support consistent implementation of departmental processes.

Supporting Priority Objective: V.3

Key Outputs

Expected Completion Date

Integration and use of Business Process Model and Notation (BPMN). December 2020

A documented business process maturity model baseline. June 2020

A roadmap for improving business process maturity in the Department. December 2020

Plans for accomplishing the expected outcome

Effective process management and governance are an integral component of the Department's QMS and helps to ensure that safeguards activities are efficient, effective and undertaken in a consistent fashion. This project continues to assess and identify opportunities for further improvement in the deployment, governance, measurement and monitoring of processes. The use of a business process maturity model to establish a baseline and identify gaps will be used to measure and assess improvement activities.

Specific activities include working to facilitate assurance that:

- Process documentation is up-to-date, valid and available.
- Process ownership is defined.
- Roles, responsibilities, accountabilities and authorities of process owners are consistently applied.
- Process compliance is standardized, defined and fully documented.
- Process design activities are developed and documented in a uniform and consistent fashion.
- Processes are reviewed and analysed for improvement opportunities.
- Process governance is strengthened.

Support for these activities continues under MSSP task USA F 2355 (Junior Professional Officer - Associate Process Design Officer) and in collaboration with project SGIS-003: Safeguards Information Systems and System Usability. Additional support may be requested for supporting business process governance including standards and practices.

Expected outcome #3

Effective quality management activities are enabled in the Department, through robust IT software, tools and applications.

Supporting Priority Objective: T.3

Key Outputs

Expected Completion Date

Implementation of an upgraded document manager software application and interface. December 2021

Implementation of an enhanced software application for condition reporting. December 2021

A process performance dashboard, which can be used by process owners and CPD to monitor and improve the effectiveness of processes in the Department (this effort is complementary to an existing prototype, which has been developed internally). December 2020

Plans for accomplishing the expected outcome

The Department uses a number of specific IT applications to support the implementation of its QMS. These are current separate and independent of other applications including the MOSAIC suite. The primary tools are:

- A document manager (DM) repository application
- A condition reporting system (CRS)

The current DM controls and releases documents for use in the Department. The CRS captures and tracks adverse events and prevents their recurrence. In conjunction with upgrading or replacing these applications, the plan calls for the evaluation of additional software tools, for corrective and

preventive action tracking; electronic workflow and approval; risk management; audit planning and measuring and monitoring the efficiency and effectiveness of processes.

MSSP support may be requested for software and/or developing practices and mechanisms to measure and monitor process efficiency and effectiveness.

Expected outcome #4	
A more robust knowledge management programme, which closes gaps identified in a recent self-assessment against the ISO 30401 standard for knowledge management.	
Supporting Priority Objective: W.3	
Key Outputs	Expected Completion Date
A process for optimizing knowledge development and sharing, as part of the Department's induction process.	March 2021
Promotional activities accompanied by educational material to further support the awareness of and commitment and support to the knowledge management programme.	December 2021

Plans for accomplishing the expected outcome

In 2018, an assessment against the ISO 30401 international knowledge management (KM) standard revealed a number of findings and recommendations; these provided a baseline score as an indicator of the maturity of the Department's knowledge management programme.

SGCP-101 will focus on addressing the following areas, which were identified as having the greatest potential for improving the overall departmental knowledge management programme:

- Knowledge management education, training and development.
- Increasing collaboration and sharing of best practices across Divisions.
- Information communication and collaboration tools.
- Connecting people to people and people to content.
 - Work in the 2018–2019 biennium was supported under MSSP task UK C 2433 (Knowledge Management - Assessment and Review) and further support may be requested to develop tools and practices to support information communication and collaboration and training as may be required

Expected outcome #5	
Enhanced financial transparency and accountability for safeguards implementation, through the continued development and refinement of the cost calculation methodology.	
Supporting Priority Objective: S.1	
Key Outputs	Expected Completion Date
Enhanced capabilities for modeling and estimating costs associated with safeguards activities.	September 2020

Plans for accomplishing the expected outcome

The cost calculation model and methodology provides the means for estimating safeguards implementation costs. In conjunction with the use of business process modeling software, the model can be further utilized to compare and evaluate different options and alternatives.

Greater deployment and standardization of business process modeling notation in the coming biennium presents an opportunity to integrate elements of the cost model into business process modeling software applications.

During this time, the project will seek to standardize processes using the Business Process Modeling and Notation (BPMN) standard 2.0 and to explore opportunities to integrate existing elements of the safeguards cost calculation model into deployed software, to be used for business process mapping and modeling.

Support for updating and refining the cost calculation model is currently provided under Task USA F 1808 (Consultant: Implementing Activity Based Costing (ABC) in the Safeguards Cost Calculation System). It is envisaged that ad-hoc support will be needed to periodically assess estimates, suggest improvements and validate the model itself.

5. In-house development tasks

The table below lists internal development activities that will continue, but which will benefit from external contributions to the project. It gives an understanding of how external stakeholders can:

- Complement existing work
- Initiate activities in under-served areas of need
- Avoid duplicate activities

Expected outcome	Task #	Task Title (Agency's task cross reference)	Description	Expected Completion Date
1	1	Forthcoming	Implement pilot key performance indicators, to monitor and report on the Department's performance	Ongoing
1	2	Forthcoming	Identify, develop and deliver customized training on quality management tools and techniques.	Ongoing
2	3	Forthcoming	Greater use of business process model and notation for business process mapping.	Ongoing
2	4	Forthcoming	Establish a baseline for the business process maturity using a business process maturity model.	June 2020
3	5	Forthcoming	Implement a new application and processes to support a more efficient and effective means for creating, delivering and accessing internal processes and procedures.	December 2021
4	6	Forthcoming	Further develop the Department's knowledge management strategy, and support the Agency's knowledge management activities.	Ongoing

6. Attachments



Department of Safeguards Quality Policy

Each one of us has the power and responsibility to ensure quality through our personal actions and dedication.

Quality is about building trust and confidence in our safeguards conclusions. Through our **Quality Management System**, we provide assurances to our stakeholders and ourselves that our safeguards activities are implemented in an efficient and effective manner.

In alignment with our strategic objective to **continually improve performance and productivity**, we are committed to ensuring the quality of our work and strengthening the capabilities necessary to fulfil our legal obligations in a professional and impartial manner.

Massimo Aparo

Massimo Aparo
Deputy Director General
Head of the Department of Safeguards
August 2018

Quality Management Principles

- Leadership
- Engagement of people
- Process approach
- Evidence-based decision making
- Improvement
- Customer focus
- Relationship management

Quality Objectives

In support of this policy, the Department is committed to:

1. **Promoting** a quality culture and encouraging ownership of quality responsibilities and accountabilities.
2. **Implementing** our quality policy and following our quality management principles in the way we work.

 | Safeguards

Figure 22: The Quality Policy

SGCP-102: Training

Project Manager: Susan PICKETT

1. Overview

The Training Section (CTR) is responsible for designing and delivering training on the various aspects of IAEA safeguards.

This chapter describes the plans for developing and implementing training during the 2020–2021 biennium.

Project objective

The overall objective is to provide effective training and learning opportunities, based on a systematic approach to training and applying the latest teaching methodologies, to ensure that the target audiences obtain the required knowledge and skills necessary to perform their tasks and implement IAEA safeguards. The intended audiences are departmental staff members and staff from organizations that form or contribute to State or Regional Systems of Accounting for and Control of Nuclear Material (SSACs) including facility operators, State and regional authorities responsible for safeguards implementation and 'owners' of Additional Protocol (AP) information.

Foreseen challenges

In 2018–2019, CTR delivered, in cooperation with Member States, over 212 courses to 2340 departmental staff members (739 distinct individuals). Training opportunities ranged from 1-day seminars to 2-week courses. In the same period, the Section delivered over 30 training courses to Member States, for the benefit of over 500 participants.

Budget constraints, staff turnover³, more stringent facility access and requirements to update management and training planning tools are some of the more generic issues that will continue to challenge the Department's training schedule and programme in 2020–2021.

Within this environment, specific challenges in the provision of training include:

- **Attracting and retaining qualified trainers.** CTR relies significantly on safeguards professionals from outside of the training section to facilitate courses, workshops and presentations. Between 2017 and 2019, CTR relied on external staff to assist in delivering over 60% of its course modules or sessions. Trainers need to be subject matter experts (SMEs), resilient and ambassadors of change, which requires a unique combination of skills.
- **Developing training for inspectors and analysts to address new technologies—** either new nuclear fuel cycle technologies or disruptive/game-changer technologies. Courses must be developed or evolve to deliver the knowledge and skills needed to apply safeguards at new types of facilities or apply new safeguards technologies at existing nuclear facilities. Designing and implementing training on new technical solutions that could enhance and improve the implementation of safeguards—such as monitoring devices—requires continual development.
- Developing a comprehensive training package for all departmental staff members that links internal IT innovations to the safeguards processes, ensuring that departmental staff members can not only effectively use the tools—such as the new applications resulting from the MOSAIC project—but develop and maintain a strong understanding of the processes, how to implement those processes and why the processes are fundamental. This is substantiated by the 2018–2019 training needs analysis.
- **Designing and implementing training for new processes in the Department,** including Acquisition Path Analysis, State Level Approach development and State Evaluation, while maintaining and enhancing a strong training programme in areas such as infield verification activities, nuclear material accountancy and environmental sampling.
- **Ensuring that SSAC training is available to SSAC staff** in SSAC training, provided by the Department as a means to optimize SSAC performance and thereby promote the overall effectiveness and efficiency of safeguards implementation

³ For example, to accommodate training needs of newly-appointed staff, the Department found it necessary to hold two Introductory Courses on Agency Safeguards simultaneously, plus five comprehensive inspection exercises, in 2018.

- **Being prepared for, and training departmental staff members on, verification challenges** (for example, early adoption of small modular reactors or preparation for possible reintroduction of inspections in the Democratic People's Republic of Korea).

Top project priorities in 2020–2021

Through the application of Systematic Approach to Training (SAT) principles, CTR continuously improves its training programme for both departmental staff members and staff in States involved in the implementation of safeguards within their country. For the coming biennium, the top project level priorities, for both audiences, are:

- Customized training
 - Develop a systematic approach to training and ensure access to current and new nuclear fuel cycle facilities for training purposes.
 - Develop competency-based training paths (in other words, sample curricula) for various job roles.
 - Provide targeted national SSAC training, through a competency-based approach, based on a training needs assessment and outcomes of State Systems of Accounting for and Control of Nuclear Material (ISSAS) missions and SSAC self-assessment tools.
- Consistency of approach
 - Ensure the consistent application of Systematic Approach to Training (SAT) principles for in-house and Member State training, to ensure high quality training.
 - Review and ensure the use of collaborative learning methods in all courses and complement the classroom training with existing and future e-learning modules, as appropriate. Blended learning opportunities—using a combination of electronic, online and classroom or face-to-face activities—might also be considered, subject to available resources.
 - Integrate some blended learning, including e-learning; content creation; virtual tools and self-directed learning, to address diverse educational needs.
- Enhanced access
 - Develop the content, teaching approach and overall delivery of e-learning or self-guided learning, so that learning opportunities are more readily accessible and reach a wider audience and in order to help build the knowledge and skills necessary for effective safeguards implementation.
 - Continue integration of safeguards training material in the IAEA e-learning platform (CLP4NET, a Moodle-based system), building on the already successful system used for many SSAC training activities.
- Improved monitoring and recording
 - To improve the effectiveness of training and ensure departmental staff members development plans keep pace with challenges, CTR must track the training provided/received and training evaluations in an accessible, usable system capable of providing timely reports and statistics on request—either for training course design or for IAEA high-level reports such as the Safeguards Implementation Report and the Annual Report. CTR receives on average 5–7 requests per month for statistics, and Divisional Training officers require such information on a daily basis to ensure staff training plans can be properly implemented.
 - Together with the internal parties responsible, development of an integrated learning management system is required, to establish staff training paths for departmental staff members and monitor learning progress. An integrated learning management system should also provide departmental staff members with access to the Departmental Training Programme and retain training records. This would

also facilitate reporting and significantly contribute to the planning and evaluation of training.⁴

2. Strategy framework linkages

IAEA's Programme and Budget project linkage

The plan and MSSP tasks detailed in this chapter are followed-up and/or coordinated by Agency staff and are aligned with the objectives of the Agency's projects #4.1.1.004 Staff training and traineeship and 4.1.1.005 Training and assistance to SSAC in the *Agency's Programme and Budget 2020–2021*.

Safeguards Research & Development Plan linkage

The Training D&IS Project supports a broad set of the Department's R&D Needs. This includes but is not limited to the following R&D Need:

Priority Objective		R&D Needs	
T.4	Manage SG technology assets strategically	T.4.R1	Execute a long-term maintenance and replacement plan for the safeguards information technology system as a follow-up to MOSAIC.
W.1	Reform human resource management	W.1.R1	Develop and maintain, through training, new expertise required by the Department, where needed, with the help of Member States.
S.3	Advance safeguards-by-design	S.3.R1	Identify and pursue opportunities for the Agency and Member States to promote the early consideration of safeguards among the nuclear industry.

3. Progress on expected outcomes, key outputs and tasks from the previous biennium

Expected Outcome #1 from the 2018–2019 Biennium		
Enhanced ability to fully implement the State Level Concept for the planning, conduct and evaluation of safeguards through the establishment of a training programme that meets the Department's needs.		
Supporting R&D Needs: V.1.R2, V.2.R1, V.5.R3 and W.1.R1		
Key Outputs	Status	Comments
Annual training programme validated for relevance and accuracy by an internal focus group meeting.	Key output achieved; work continues	Training needs are assessed annually through meetings and discussions with Divisional management and Divisional training officers.

⁴ As of September 2019, the Agency has signed a contract with Oracle to develop the Oracle Learning Management. It is not yet known to which extent this new system to "manage" learning (and training) will address Departmental learning, training and staff development needs. CTR is coordinating Departmental involvement with Divisions and SPC. If the system does not fully address Departmental requirements, CTR and SGIS will determine next steps, together with Departmental stakeholders.

Expected Outcome #2 from the 2018–2019 Biennium

Enhanced ability to detect undeclared nuclear material and activities through development and delivery of relevant training.

Supporting R&D Needs: V.1.R2, V.2.R1, V.5.R3, P.5.R2 and W.1.R1

Key Outputs	Status	Comments
Results of an internal focus group meeting to verify the application and relevance of training on analytical techniques.	Key output achieved; work continues	Improvements are being implemented based on the results of course evaluations and meetings with Divisional training officers.
Training courses on information collection and analysis developed and delivered in accordance with the Annual Departmental Training Programme.	Key output achieved; work continues	Courses such as Satellite Imagery Analysis, Open Source Awareness, Export/Import and Palantir Analytic Context were delivered. Continuous improvements are being made on the Systematic Approach to Training (SAT).

Expected Outcome #3 from the 2018–2019 Biennium

Enhanced ability to safeguard new types of facilities through identification of training needs and training delivery to reflect the approaches and equipment for safeguarding these new facility types, including consultation with States developing such facilities.

Supporting R&D Needs: P.5.R1 and P.5.R2

Key Outputs	Status	Comments
Results of an internal focus group meeting to identify training needs related to safeguarding of pebble-bed reactors, small modular reactors and molten salt reactors.	On hold	This activity is on hold. Because of training needs, assessments have identified higher priorities.
Training courses covering new types of facilities developed and delivered in accordance with the Annual Departmental Training Programme.	Delayed; work in progress	Over the past 2 years, CTR continued to implement and update courses on existing facilities in the nuclear fuel cycle.

Expected Outcome #4 from the 2018–2019 Biennium

Maintained and enhanced ability to deploy the required expertise and skills to continue to fulfil the IAEA's mandate(s) through development and delivery of relevant training courses.

Supporting R&D Needs: T.1.R3, T.1.R4 and W.1.R1

Key Outputs	Status	Comments
Development of a Bulk Handling Facilities Training Course with at least two additional MSSPs.	Delayed; work in progress	CTR is continuing to work with Member States to address a lack of appropriate and available facilities for training.
Training courses at locations offered by Member States Support Programmes covering the full set of technical and integrated content in the IAEA Training Programmes for 2018 and 2019.	Key output achieved; work completed	Over 25 courses were successfully delivered in nuclear facilities.
Development and delivery of a course on writing skills for safeguards.	On hold	Presently, there are new Agency-wide courses and learning opportunities for the development of writing skills. CTR is considering re-introducing a technical safeguards writing course, which was previously offered.

Full management of the safeguards training programme through the Learning Management System (LMS) deployed within AIPS Plateau 3.

Delayed; work in progress

The Department relies on an external acquisition project to complete this output; SGCP and SGIS are coordinating with the Division of Human Resources (MTHR) to determine how the Agency-wide solution may address Department learning management needs.

Expected Outcome #5 from the 2018–2019 Biennium

Developed training tools, using also advanced methods such as virtual reality, immersive learning systems and web-based training.

Supporting R&D Need: T.5.R5

Key Outputs	Status	Comments
Results of an internal focus group meeting to evaluate needs for developing new tools supporting mission preparation and retention of critical knowledge.	Key output achieved; work continues	Next steps identified; e-learning and blended learning training modules developed.
Computerized model of a bulk handling facility.	Key output achieved; work completed	CTR/MSSPs worked together to develop a computerized model of a fuel fabrication facility
Training manual on Spent Fuel and Waste Management.	On hold	Rescheduled to be completed by June 2021.

Expected Outcome #6 from the 2018–2019 Biennium

Effective and efficient support to SRA's training through training delivery and development of training material and remote delivery methods.

Supporting R&D Needs: T.3.R1 and S.2.R1

Key Outputs	Status	Comments
Training programme to support SSACs in developing their capabilities for collecting safeguards relevant information within the country and for conducting domestic inspections.	Key output achieved; work continues	CTR implements SSAC courses at the national, regional and international levels to ensure that States with safeguards agreements have the knowledge and skills to develop their SSAC. This programme relies entirely on extrabudgetary financial support.
Training courses for SRAs developed and delivered as requested.	Key output achieved; work completed	CTR held over 20 SSAC courses in 2018–2019.

4. Expected outcomes, key outputs and tasks for the 2020–2021 biennium

In order to achieve overall objectives and meet R&D needs, tasks must be initiated, continued and/or finalized during the 2020–2021 biennium. The following expected outcomes serve as an outline for the next 2 years.

Expected outcome #1	
Competent and confident departmental staff members (including support staff, analysts, inspectors and managers) who have the knowledge and skills to conduct safeguards verification activities at headquarters and in the field and have the analytical, technical, communication and leadership skills to implement safeguards.	
Supporting R&D Need: W.1.R1	
Key Outputs	Expected Completion Date
Training in fundamental safeguards competencies and associated safeguards processes (skills associated with safeguards measures and activities, such as nuclear material accountancy, non-destructive assay, design information verifications, etc.).	December 2021
Initial training offerings for new, emerging and/or unexpected NFC and safeguards technologies (for example, Design Information Verification (DIV) training in SMRs or facilities undergoing decommissioning).	December 2020
Development of a comprehensive industrial safety curriculum/programme for inspectors.	June 2021
Training in the State Evaluation process and associated skills.	September 2021

Plans for accomplishing the expected outcome

CTR strives to achieve its mission of providing Department staff and Member States with high quality and accessible learning opportunities—to develop competence in the fundamentals, implementation and evaluation of safeguards—through an optimum combination of in-house and extrabudgetary support. The regular budget pays for the salaries of Agency training staff and basic operating costs, some travel for departmental staff members and the Traineeship Programme in part. Extrabudgetary support is required for most training courses and course travel, as well as for Cost Free Experts.

In order to accomplish the expected outcome, CTR will continue to rely upon MSSPs to provide knowledgeable and experienced trainers in areas of the nuclear fuel cycle, nuclear materials processing and facility operations, as well as access to facilities to provide the opportunity for safeguards inspectors and analysts to learn hands-on fundamental skills. As of December 2019, CTR has 72 active tasks with 17 Member State Support Programmes that provide opportunities for departmental staff members to learn and develop their knowledge and skills to conduct verification activities, including the basic technical skills necessary in areas such as non-destructive assay and containment and surveillance application, as well as in the broader scope of the conduct of infield verification activities. For the 2020–2021 biennium, four key outputs will require MSSP assistance:

- Fundamental Safeguards Competencies
 - In order to ensure that departmental staff members have the required competencies in fundamental skills, such as nuclear material accountancy (NMA) and in infield verifications, the Department regularly assesses course material and objectives. For example, as a result, NMA seminars are under development, and a new criticality check refresher was implemented in October 2019 and will be offered in 2020.
 - One major challenge that the Agency faces is sufficient availability of facilities and their access for training, in particular for inspector fundamental courses such as the Nuclear Power Plant Comprehensive Inspection Exercise (CIE) (a required component of the Introductory Course on Agency Safeguards, ICAS) and Spent Fuel Verification. During 2018–2019, CIEs have been provided by the Czech Republic, Hungary, Sweden and Slovakia; the German Support Programme is considering making available a facility for a CIE in 2020. Additionally, the Spent Fuel Verification Training, currently supported by Canada, Finland and Sweden, requires access to spent fuel of varying types, burn-up and age, in order to provide inspectors with the opportunity to practice and train in verification activities of infield activities. CTR will continue to work with the existing MSSP contributors and submit new task

proposals to expand the network of facilities and pool of expertise available for training.

- Nuclear Fuel Cycle and Safeguards
 - The IAEA relies on MSSPs to provide facilities that cover a range of NFC activities, for infield visits and hands-on training. The MSSP tasks and facility access provided by Member States form a vital part of the Department’s training programme and, as seen from the examples below, these courses address all phases of the nuclear fuel cycle and related technologies:
 - Hot Cell and Glove Box Verification through MSSP task USA B 2202 (Hot Cell and Glove Box Verification Training)
 - Additional Protocol Exercises through MSSP tasks HUN B 1525, USA B 1415, EC B 1563, FRA B 1427 (Workshop on Additional Protocol Activities)
 - Comprehensive Inspection Exercises at CANDU reactors, LWR and Bulk Handling plants through MSSP tasks ROK B 1872 (Advanced Comprehensive Inspection Exercise at CANDU and LWR Facilities), SWE B 1328 (Comprehensive Inspection Exercise for Bulk Handling Facilities), UK B 1990 (Design Information Verification at Bulk Handling Facilities Training Course), ROK B 1907 (Development of Virtual Training for Bulk Handling Facilities) and ROK B 1895 (Comprehensive Inspection Exercise at Bulk Handling Facilities)
 - Centrifuge enrichment safeguards-related training through MSSP tasks RUS B 1053 (Training in Implementation of Safeguards at Uranium Gas Centrifuge Enrichment Plants), NET B 1852 (Practical Safeguards at Gas Centrifuge Enrichment Plants), UK B 1797 (Implementation of Safeguards at Enrichment Facilities), GER B 1896 (Practical Safeguards Training at Enrichment Plants) and USA B 1001 (Safeguards Training Course: Enrichment Technology)
 - Non-Destructive Assay techniques used in safeguards throughout the fuel cycle through MSSP tasks USA B 0086 (Training - IAEA Participation in US Sponsored Courses), EC B 1702 (NDA Training Course), RUS B 1719 (Training on Advanced Pu Verification Techniques) and USA B 2256 (Training Course on Plutonium Diversion Detection Scenario)
 - Nuclear Fuel Cycle and Indicators training courses through MSSP tasks UK B 1991 (Training on the Nuclear Fuel Cycle, Indicators and Proliferation Pathways) and UK B 1903 (Advanced Training on NFC Facilities to Assist State Evaluation)
 - MSSP training tasks, including those listed above, form the backbone of the safeguards training section and provide the Department with the range of internal courses necessary to ensure that inspectors and analysts have the knowledge and skills necessary to contribute effectively and efficiently to the IAEA’s fulfilment of its obligations to Member States.
 - Training in the range of NFC technologies is crucial, not only for infield verification activities but also in the development of State Level Approaches and evaluation of the State as a whole. Currently, there is a need for training in the front-end of the NFC; in particular, in uranium mining, milling and conversion. CTR is working with the Department of Nuclear Energy to hold a Uranium Mining and Milling seminar and expects to propose a new task proposal for MSSP consideration in this area. Furthermore, fundamental technology knowledge could be enhanced in areas such as accelerators and laser enrichment (lab scale and indicators) to complement the current curriculum; this would not necessarily be required on an annual basis, but would be planned according to departmental needs and MSSP availability.
- Industrial Safety
 - Presently, the inspector curriculum lacks comprehensive industrial safety training. The Department has relied upon MSSPs to provide issue-specific courses, such as the Fall Arrest Course under MSSP task CAN B 2495 (Fall Arrest Training Course). In order to provide support and safety awareness, CTR seeks support to develop a basic industrial safety course for IAEA inspectors by 2021. This will require an assessment of the safety needs and the subsequent development of, possibly a ‘blended learning’ comprising on-line and in-person components.

- State evaluation training
 - The quality of State evaluation depends on Departmental processes as well as the systematic use of structured analytical techniques. The United States, United Kingdom and Australian Support Programmes contribute to training on analytical skills in support of State Evaluation. The Department, in defining the State evaluation process, requires training for managers and State Evaluation Groups (SEGs) on the integration of critical thinking and structure analysis into the process. Practical training should also contribute to setting an expectation that State evaluation is conducted and documented according to standard practices. A 'State evaluation curriculum' should offer basic skills, a State evaluation process overview and facilitated workshops that apply newly-acquired knowledge to practical cases. CTR is coordinating with other Divisions and Offices (SGCP, SGIM and the Section for Safeguards Programme Coordination (SPC)) to define such a curriculum. The review and alignment of the aforementioned tasks with this curriculum is a crucial step.

Expected outcome #2	
Competent and confident departmental staff members within the organizations of an SSAC, with the knowledge and skills to effectively implement safeguards and fulfill safeguards obligations.	
Supporting R&D Need: W.1.R1	
Key Outputs	Expected Completion Date
An implemented training programme for Member States that addresses international, regional and national requests and needs as identified through State evaluations and operational requirements.	December 2021
Updated ISSAS guidelines and outreach campaign to States, to increase awareness of ISSAS missions.	June 2021
Development of State SSAC self-assessment guide (for example, a 10-point review guide).	December 2021
Development of two or three e-learning modules for States with a Comprehensive Safeguards Agreement (CSA) on State obligations and NMA for Small Quantity Protocol (SQP) States.	November 2021

Plans for accomplishing the expected outcome

In order for States to fulfill their obligations to the international community in accordance with their safeguards agreements, they need to have competent and confident departmental staff members who are knowledgeable in the legal basis of safeguards, nuclear material accounting, information management and infield verification activities.

Over 30 SSAC courses were held from 2017–2019, involving over 450 individuals from Member States receiving training. These courses would not have been possible without Member States' extrabudgetary support.

The Department plans to continue to hold similar training events and has already received requests for national training courses during the 2020–2021 biennium. CTR works closely with SGIM and the Operations divisions to tailor each training course for staff of organizations involved in an SSAC. All training offered to Member States is supported by extrabudgetary support, including facility access for its international, regional and national training courses under MSSP tasks BRZ B 1811 (Regional Training Course on SSAC, Brazil), JPN B 2273 (Expert - SG SSAC Senior Training Expert), ROK B 2340 (SSAC Course for Newcomer States), ROK B 2368 (Expert - SSAC Training Officer), RUS B 1107 (Training Courses for SSAC Personnel), USA B 2417 (Expert - State Systems of Accounting for and Control of Nuclear Material (SSAC) Training) and FIN B 1939 (Support for Newcomer States Pursuing a Nuclear Power Programme).

Coordination with stakeholders—through international, regional or national courses—ensures that training is consistent with reference documents published by the IAEA, supporting the development and maintenance of SSACs and enabling States to meet IAEA safeguards requirements regarding collection, processing and communication to the IAEA of safeguards-relevant and accurate information required under safeguards agreements and protocols.

Several initiatives have already been taken, such as exchanging lecturers, developing joint training material and sharing schedules. These developments have involved collaboration with international

networks including, amongst others, the International Nuclear Security Education Network (INSEN) and the Asian Pacific Safeguards Network (APSN).

CTR plans to enhance its communication with Member States and other networks and, through improved evaluation mechanisms (see Expected Outcome #4), provide evaluation feedback to the MSSPs supporting such courses. Additionally, the Department is fully involved in the implementation of integrated work plans, developed as a follow-up to Integrated Nuclear Infrastructure Review Missions; preparation of reference documents by the Department of Nuclear Energy and regular Infrastructure Coordination Meetings organized by the Department of Nuclear Energy for areas of safeguards concern. This is an important collaboration, through which CTR supports optimum involvement of Member States' stakeholders and resources, ensuring consistency both in the development of training material for nuclear energy and/or safeguards implementation and in the provision of SSAC training to address Member State needs.

CTR intends to promote ISSAS missions through an outreach campaign, raising their visibility and the opportunity for a State to seek assistance from the Agency in the development of its SSAC. MSSPs have provided extrabudgetary support to facilitate ISSAS missions—enabling two to be undertaken in 2019—and their success will continue to rely upon the support of MSSPs. Further support will be required to update the ISSAS guidelines, an additional activity proposed in the 2020–2021 biennium.

The Agency intends to involve MSSPs in a technical meeting, to address the development of a self-assessment questionnaire for SSACs. The self-assessment questionnaire will be coordinated with the State Questionnaire, which is currently being internally developed under an action of its strategic plan.

E-learning can provide important additional opportunities for staff of State Regulatory Authorities to learn the fundamental skills needed in an SSAC. While e-learning is not a substitute for in-person learning opportunities, it can complement or supplement in-person training courses and offer an alternative source of knowledge for those who are unable to attend in-person at IAEA SSAC training events. In conjunction with SGIM-009: State-Declared Information Management and with Member State Support Programmes, CTR intends to develop two to three e-learning modules for Member States.

In delivery of outcome #2, the Agency receives essential support from four Cost Free Experts within the Member State Training Team. They ensure the delivery of SSAC training, work with the Integrated Nuclear Infrastructure Review (INIR) missions and assist with the development of self-assessments through MSSP tasks JPN B 2273 (Expert - SG SSAC Senior Training Expert), ROK B 2368 (Expert - SSAC Training Officer), USA B 2109 (Expert - Nuclear Instrumentation Training Expert) and USA B 2417 (Expert - State Systems of Accounting for and Control of Nuclear Material (SSAC) Training).

Expected outcome #3

Bolstered awareness/interest/passion/knowledge of importance of safeguards in the international community (for example, university professors teaching law or Nuclear Engineering, Member States with safeguards agreements, "next generation" university students).

Supporting Priority Objective: W.4

Key Outputs

Expected Completion Date

Gap analysis of outreach materials (inventory of existing material and identified priority materials requiring development.	June 2020
Development of sample curriculum of IAEA SG basics.	June 2020
Packaged assortment of SG materials (such as a starter kit in SG knowledge, including recommended reading for educational purposes).	September 2020

Plans for accomplishing the expected outcome

Bolstering safeguards education, to build the next generation of safeguards experts, is an "Idea for Action" from STR-392: *2018 Symposium on International Safeguards: Building Future Safeguards Capabilities Report* (available at <https://www.iaea.org/events/symposium-on-international-safeguards-2018>).

The IAEA has extensive material available as a resource for Member States and frequently provides information through Member State courses or outreach. However, such material is not readily available in a single package for those interested in teaching or learning more about international

safeguards. Support is required to take a simple inventory of available material, repackaging some material and providing it in a format that is readily available to the broader international community. In response to Member State requests, CTR plans to develop a high-level sample curriculum, which could be offered to universities for integration into broader non-proliferation curricula.

Expected outcome #4	
Increased quality and accessibility of training and learning through modernization of facilities in and modes of course offerings.	
Supporting R&D Need: T.4.R1	
Key Outputs	Expected Completion Date
"Train-the-Trainer" courses available to CTR staff for training in best practices.	June 2021
Inventory of all courses and assessment of which courses are suitable for e-learning or an e-learning component.	June 2020
E-learning modules and blended courses available for internal and external staff.	December 2021
A training material database.	December 2021

Plans for accomplishing the expected outcome

In order to maximize the benefit from available resources, it is crucial to provide innovative and accessible training opportunities. CTR staff need training themselves—in both course development and delivery—so that every training event is designed and delivered to optimize the learning experience and the retention of knowledge and skills. CTR will work with MTHR and Member States to provide training to staff and implement orientation and guides to facilitate training that adheres to Systematic Approach to Training (SAT) principles and delivery.

Secondly, the IAEA will develop a strategy to implement training that integrates computer-based learning, such as e-learning, within innovative blended learning modules.

In accordance with the R&D Plan (STR-385), CTR is already developing e-learning modules for both internal and external courses. MSSP support is sought, to enhance the deployment of e-learning through provision of a training officer in the e-learning area who would consistently work to assess, design and develop appropriate e-learning components, ensuring their delivery in line with the Agency e-learning platform. Such a position would also ensure that CTR staff remain up-to-date in relevant learning and instructional design.

With regard to the fourth output, CTR needs a streamlined approach to managing course content so that it is readily indexed by competency and safeguards area of expertise. Presently, the training material is not readily indexed or tagged. This output would be the development of a training material database; an in-house project with SGIS-003: Safeguards Information Systems and System Usability. However, MSSP support could facilitate this activity by providing guidance and sharing of good practices.

Expected outcome #5	
Increased knowledge of safeguards and aspects of the nuclear fuel cycle in Member States with limited or no nuclear fuel cycle technologies.	
Supporting R&D Need: S.3.R1	
Key Outputs	Expected Completion Date
Yearly implementation of the Safeguards Traineeship Programme.	December 2021

Plans for accomplishing the expected outcome

The IAEA Safeguards Traineeship Programme represents a significant investment of Agency resources in promulgating knowledge of safeguards and pertinent aspects of the nuclear fuel cycle to Member States with limited or no nuclear fuel cycle technologies. It benefits the Department through enhanced cooperation and safeguards-relevant reporting from these States. MSSP support to this critical programme, both financial and in-kind, is currently being solicited through the task proposal IAEA Safeguards Traineeship Programme Support. Multiple MSSP acceptance of the task will assist in facilitating the continuation of this important Agency initiative.

5. In-house development tasks

The table below lists internal development activities that will continue, but which will benefit from external contributions to the project. It gives an understanding of how external stakeholders can:

- Complement existing work
- Initiate activities in under-served areas of need
- Avoid duplicate activities

Expected outcome	Task #	Task (Agency's cross reference)	Title task	Description	Expected Completion Date
Optimized learning management	1	Oracle Learning Management (OLM)		Implementation of the IAEA learning management system under development by Oracle and HR; where Oracle is not able to address SG needs, work with SGIS to develop IT tools internally.	HR – Oracle dependent
Training on State evaluation process	2	Strategic Planning Action V.2.2 Departmental Project 4.1.1.004-2020-01		Work within the Department to develop training on the State evaluation process. This includes new training on APA and SLA development.	
SEGs working more effectively as a team	3	Strategic Planning Departmental Project 4.1.1.004-2020-02		In order to ensure State Evaluation Groups work as teams, CTR is developing and implementing a series of one-day workshops; these will be coordinated with SPC, SGIM, and Divisions of Operations	Pilot January 2020
Increased staff knowledge of and ability to work with ISE applications in alignment with SG processes	4	Departmental Project 4.1.1.004-2020-03		Training on ISE Applications through training on SG processes/ with SGIS	

6. Attachments



Figure 23: Locations of IAEA State Systems of Accounting for and Control of Nuclear Material Advisory Service (ISSAS) missions since 2004



Figure 24: 64th IAEA NDA Inspector Training Course in Los Alamos, New Mexico, USA, August 2019



Figure 25: ICAS #67 in Czech Republic on CIE



Figure 26: Tajikistan, 2018 National Training Course



Figure 27: Kyrgyzstan, 2019 National Training Course

SGIM-002: Satellite Imagery Analysis

Project Manager: Marc LAFITTE

1. Overview

This chapter describes the plans for developing satellite imagery analysis capabilities within the Department during the 2020–2021 biennium.

Project objective

Satellite imagery analysis plays a significant role in monitoring nuclear fuel cycle (NFC) sites and activities, verifying States' declarations, planning and supporting IAEA verification activities and detecting and investigating undeclared activities. The IAEA's satellite imagery and geospatial capability resides with the State Infrastructure Analysis (ISI) team.

The overall objective is to continuously improve and enhance the IAEA's ability to acquire, analyse and exploit satellite imagery and geospatial information to support nuclear verification activities.

Foreseen challenges

During the last 20 years, satellite imagery analysis has become an increasingly valuable and unique source of independent, safeguards-relevant information supporting safeguards implementation by the IAEA. The Department faces a number of ongoing challenges in maintaining its capacity for detailed analysis of satellite imagery and all-source geospatial information; an essential element of the IAEA's verification regime. The commercial satellite imagery (CSI) marketplace has seen a larger number of competing vendors offering lower costs, new multi-sensor earth observation satellites, expanding satellite constellations, improved imaging capabilities and greater collection opportunities around the globe. Systematically acquiring, processing, storing, disseminating and exploiting this ever-increasing volume and diversity of CSI has set new, more demanding and unforeseen burdens on the Department's existing resources.

To improve processes, workflows and methodologies that will further enhance the Department's ability to manage, analyse and disseminate satellite imagery and geospatial analysis, the Department must continue to attract experienced staff with a strong technical background in imagery analysis and a workable knowledge of Geographic Information System (GIS) software and provide them with training opportunities to further improve their understanding of the nuclear fuel cycle and its imagery signatures. Increasing demands within the Department for geospatial information, the requirements for monitoring in areas of safeguards-related concerns or conflicts where the IAEA has no direct access and the need to integrate and exploit safeguards-relevant information across the Department all pose significant challenges that require ongoing development and long-term investments.

Top project priorities in 2020–2021

- Maintain and enhance in-house satellite imagery and geospatial analytical processes and capabilities.
- Enhance and develop in-house competencies to better support the State evaluation process.
- Promote dissemination of satellite imagery and geospatial analysis and collaborative analysis within the Department through interoperability with in-house systems.

2. Strategy framework linkages

IAEA's Programme and Budget project linkage

The plan and MSSP tasks detailed in this chapter are followed-up and/or coordinated by Agency staff and are aligned with the objectives of the Agency's project #4.1.5.003 State infrastructure analysis in the *Agency's Programme and Budget 2020–2021*.

Safeguards Research & Development Plan linkage

Priority Objective	R&D Needs
T.3 Support all SG processes through IT	T.3.R3 Build on the development of geographic information system (GIS) technology to enhance geo-based information sharing and related analysis.
V.1 Strengthen information	V.1.R1 Enhance the set of expert tools necessary to process the variety of SG-relevant information and implement them,

collection and analysis		with emphasis on timely responses and cost-effectiveness.
	V.1.R3	Further integrate safeguards information to strengthen all-source information analysis and make it more user-friendly (for example, via the Collaborative Analysis Platform).
V.4	Enhance SG effectiveness monitoring and evaluation	V.4.R1 Identify and deploy analytical tools, including data visualization, to better measure and analyse performance and take advantage of capabilities provided by MOSAIC.
W.1	Reform human resource management	W.1.R1 Develop and maintain, through training, new expertise required by the Department, where needed, with the help of Member States.

Collaborating D&IS projects

- SGIM-003: Information Analysis
- SGIM-009: State Declared Information Management
- SGIS-003: Safeguards Information Systems and System Usability
- SGTS-008: Instrumentation Technology Foresight
- SGCP-102: Training

3. Progress on expected outcomes, key outputs and tasks from the previous biennium

Expected Outcome #1 from the 2018–2019 Biennium			
Enhanced analytical process through evaluation and testing of new sensors, imaging capabilities, tools and techniques and provision of more and different information to the analysts.			
Supporting R&D Needs: T.3.R3, V.1.R1 and V.4.R1			
Key Outputs	Status	Comments	
Advanced radar techniques incorporated into routine imagery analytical reporting.	Key output achieved; work continues	Synthetic Aperture Radar (SAR) satellite sensors are increasingly available to the IAEA through commercial vendors. These, and other emerging sensors, such as Short Wave Infrared (SWIR), provide the Department with new, high value information that cannot be obtained from the more conventional optical satellite sensors from Canada, German, Japan and French Support Programmes. Specialist Cost Free Experts (CFEs) from Canada and United States Support Programmes lead the effort to continue to evaluate, improve, develop and apply new safeguards-applicable techniques, software and data.	
Commercial satellite imagery acquired from diverse sources to ensure the integrity and authenticity of satellite imagery as an open source of information.	Key output achieved; work continues	The commercial market for satellite imagery has continued to expand in recent years. New, high spatial and spectral resolution sensors with significantly improved re-visit times provide unprecedented opportunities to monitor NFC-related sites and activities around the globe. The MSSP task UK D 1329 (Support for SGIM Analysis) has allowed the IAEA to acquire this kind of imagery when required.	

Expected Outcome #2 from the 2018–2019 Biennium		
Enhanced staff skills in processing and analysing satellite imagery to detect signatures of undeclared activity, improve analysis of nuclear fuel cycles, and better support the State evaluation process.		
Supporting R&D Need: W.1.R1		
Key Outputs	Status	Comments

Training on Esri GIS Applications in support of GES enhancements.	Key output achieved; work continues	Training in GIS applications provides departmental staff members with the skills and awareness of software capabilities to fully exploit the capabilities offered by the Geospatial Exploitation System (GES) infrastructure and has been supported by MSSP task USA B 1442 (Specialist Training for IAEA Imagery Analysts).
Attendance at geospatial international conferences (GEOINT, Esri).	Key output achieved; work continues	Attendance at key satellite imagery and GIS industry events provides departmental staff members with an essential opportunity to gain valuable and practical insight into new and emerging developments. Priority events include GEOINT Symposium, DGI Europe and Esri annual conferences. These are typically supported using a combination of regular budget and MSSP contributions through MSSP tasks UK D 1819 (Nuclear Fuel Cycle Specialist Assistance) and USA B 1442 (Specialist Training for IAEA Imagery Analysts).
On-site training in imagery observables of the nuclear fuel cycle.	Key output achieved; work continues	To improve the IAEA's capability to monitor NFC sites by CSI, on-site familiarisation training visits are conducted at NFC sites. This training activity, specifically tailored for IAEA imagery and geospatial analysts, is used to relate observables of NFC infrastructure and activity to CSI. This initiative remains a critical training requirement within SGIM-ISI and is supported through MSSP tasks CAN B 1484 (Specialist Training for IAEAs Imagery Analysts), GER B 1457 (Training in Software and Hardware and Database Provision for Satellite Imagery Analysis Support) and SWE B 1504 and USA B 1442 (Specialist Training for IAEAs Imagery Analysts).

Expected Outcome #3 from the 2018–2019 Biennium

Enhanced collaborative analysis through enabling the consumption of information from other relevant applications (for example, the Additional Protocol System (APS) and Safeguards Master Data (SGMD)) and exposing geospatial information to other applications in the Integrated Safeguards Environment (ISE) (for example, State File, Collaborative Analysis Platform and Geospatial Data Integration).

Supporting R&D Need: V.1.R3

Key Outputs	Status	Comments
Release of upgrades to the GES: an enterprise task management system, additional data management capabilities, and the capability to interact directly between expert applications (RemoteView/Esri ArcGIS).	Key output achieved; work completed	In 2017, the Department deployed GES Web 2.0 in full coordination with the Modernization of Safeguards Information Technology (MOSAIC) project. Upgrades have included improving and expanding the functionalities of the GES, including the incorporation of evolving satellite sensor systems; development of a task management system; ingestion of State-declared digital site maps and integration with the Additional Protocol System (APS), with support through MSSP tasks CAN D 1976, FIN D 1996, GER D 1983 and JPN D 1995 (Digital Declaration Site Maps (DDSM)).

4. Expected outcomes, key outputs and tasks for the 2020–2021 biennium

In order to achieve overall objectives and meet R&D needs, tasks must be initiated, continued and/or finalized during the 2020–2021 biennium. The following expected outcomes serve as an outline for the next 2 years.

Expected outcome #1	
Enhanced analytical capability through evaluation and use of new satellite sensors, imaging capabilities, software tools, analytical/processing techniques and provision of expert personnel. Supporting R&D Needs: T.3.R3, V.1.R1 and V.4.R1	
Key Outputs	Expected Completion Date
Incorporation of new multi-sensor satellite imagery analysis (SAR, SWIR, hyperspectral) into imagery analytical products.	December 2021
Diversify commercial sources of satellite imagery to ensure the integrity and authenticity of satellite imagery as an independent source of information for the Agency.	December 2021
Enhance satellite imagery acquisition and analysis through the exploitation of satellite vendor streaming services.	December 2021
Provision of personnel with a strong technical background in satellite imagery analysis, geospatial analysis or image processing.	December 2021

Plans for accomplishing the expected outcome

The commercial satellite imagery industry offers the IAEA a broad range of satellite imagery, from which imagery and geospatial analysts extract safeguards-relevant information for use in the State evaluation process. To supplement the more conventional optical satellite imagery used by the Agency since the late 1990s, specialized sensors are available that provide new insights into activities and infrastructure at NFC facilities around the globe. To date, Synthetic Aperture Radar (SAR) imagery has proven to be a highly valued source of unique safeguards-relevant information previously not available to the Agency, and it is expected that the use of other new sensors, including Short Wave Infrared (SWIR) data, can be similarly successful.

The evolution of the commercial satellite industry offers potentially significant improvements and new analytical capabilities to the role of satellite imagery in safeguards. There is more multi-sensor satellite imagery available to the Agency than ever before, and commercial vendors are increasingly offering, at cost, unprecedented access to their archived libraries of commercial satellite imagery as a new service. This offers the IAEA unique opportunities to monitor sites and activities around the globe and provide better analysis with higher levels of confidence, which ultimately supports the strengthening of IAEA safeguards.

The new two-year plan sees ongoing and potential new support from MSSPs for:

- Continued acquisition and analysis of multi-sensor satellite imagery and geospatial data under MSSP tasks UK D 1329 (Support for SGIM Analysis) and JNT D 1657 CAN, GER, FRA and JPN (Signatures of Nuclear Fuel Cycle Related Processes (Satellite Imagery/Space Borne Remote Sensing Data))
- New access to commercial satellite provider services under MSSP task UK D 1329 (Support for SGIM Analysis)
- Provision of experienced satellite imagery and geospatial personnel under MSSP task CAN D 2018 (Expert - Satellite Imagery), UK D 2442 (Expert - Safeguards Information Analyst (Satellite Imagery)), USA D 2313 (Expert - Geospatial Expert) and USA D 2435 (Junior Professional Officer - Associate Safeguards Information Analyst (Satellite Imagery)).
- Evaluation of new software tools to fully exploit emerging satellite imagery technologies under MSSP tasks JNT D 1657 FRA (Signatures of Nuclear Fuel Cycle Related Processes (Satellite Imagery/Space Borne Remote Sensing Data)) and SWE D 1706 (Software, Hardware and Database Provision for Satellite Imagery Analysis Support).

Expected outcome #2
Enhanced staff skills in processing and analysing satellite imagery, improved analysis of nuclear fuel cycle imagery signatures and increased awareness of satellite imagery analysis throughout the Department. Supporting R&D Need: W.1.R1

Key Outputs	Expected Completion Date
Attendance at satellite imagery and geospatial international conferences (GEOINT and Esri).	December 2021
Onsite familiarization visits to nuclear fuel cycle sites.	December 2021
Satellite imagery and geospatial training courses and workshops.	December 2021

Plans for accomplishing the expected outcome

The commercial satellite imagery industry continues to evolve with new companies, sensors, larger satellite constellations new imagery-derived products and new analytical methodologies. To meet the current and future challenges of supporting safeguards implementation for the IAEA, the Department needs to be able to identify new satellite and analytical capabilities and apply them to safeguards. Over the past several years, this project has identified a small number of important satellite and geospatial conferences that allow imagery and geospatial analysts to gain valuable insight into current industry developments in the collection, processing and dissemination of satellite imagery and the integration of all source information. These conferences provide participants with a unique opportunity to network with representatives from leading and new commercial imagery providers, and other imagery-related agencies and vendors, and to gain first-hand knowledge on the latest advances and upcoming developments in imagery and geospatial technology and analytical techniques.

There remains an ongoing requirement for the Agency to develop and maintain a team of well-trained, experienced imagery and geospatial analysts. A key training initiative was to establish, with the support and participation of various MSSPs, a number of tailored familiarization visits to nuclear fuel cycle facilities around the globe. These practical, onsite visits allow imagery and geospatial analysts the opportunity to better understand infrastructure and activities at NFC sites, to engage with the facility operators and key site personnel and to identify and relate observables of NFC infrastructure and activity to satellite imagery.

Ensuring that the Department continues to utilize the in-house satellite imagery and geospatial expertise and capability that has been developed remains an ongoing priority. Both external and in-house expertise supports formal training opportunities, where participants are able to more fully understand how satellite imagery fits into the State evaluation process and supports on-site verification activities. This training is conducted in close coordination with the Division of Concepts and Planning (SGCP).

The new two-year plan sees ongoing and potential new support from Member States for attendance and participation at select satellite and geospatial conferences, workshops, symposia and training courses under MSSP tasks NET B 1851 (Training on Satellite Imagery for Safeguards Applications), UK D 1819 (Nuclear Fuel Cycle Specialist Assistance) and USA B 1442 (Specialist Training for IAEA Imagery Analysts). Further opportunities will be sought to visit additional NFC sites for familiarization visits, especially where there are recognized gaps in the existing training programme through MSSP tasks CAN B 1484 (Specialist Training for IAEAs Imagery Analysts), GER D 1457 (Training in Software and Hardware and Database Provision for Satellite Imagery Analysis Support), SWE B 1504 and USA B 1442 (Specialist Training for IAEAs Imagery Analysts).

Expected outcome #3	
Enhanced collaborative analysis through enabling the analysis of safeguards-relevant information from other relevant applications (for example, Additional Protocol System (APS) and Safeguards Master Data) and exposing geospatial information to other applications in Integrated Safeguards Environment (ISE) (for example, Collaborative Analysis Platform (CAP) and Geo-Based Data Integration (GDI)).	
Supporting R&D Need: V.1.R3	
Key Outputs	Expected Completion Date
Enhance processes and workflows for the collection and dissemination of satellite imagery and geospatial data.	December 2021

Plans for accomplishing the expected outcome

In 2017, the Geospatial Exploitation System (GES) was upgraded. The GES is an enterprise-wide, collaborative platform that uses commercial off-the-shelf (COTS) GIS technology to provide a secure gateway into the Department's extensive commercial satellite imagery repository and geospatial data holdings. Originally deployed with MSSP support in late 2011, the GES has become an important

enabler within the Department. However, with increasing demands on the GES to incorporate and exploit increasing volumes of CSI and geospatial data, the GES required modernization, and GES Web 2.0 was launched in 2017.

Ensuring that the Department optimizes the use of its commercial satellite imagery and geospatial holdings is essential. Pivotal to this is the interoperability of the GES with other existing and new in-house systems, applications and collaborative platforms. One such development that will significantly benefit from the new GES Web 2.0 is the Geo-Based Data Integration (GDI) platform. Released in 2017-2018, the GDI is an in-house solution that was developed as part of the MOSAIC project. It allows for the integration and visualization of spatial safeguards-relevant information collected across the Department, particularly in the Operations divisions, with the extensive commercial satellite imagery repository and geospatial data holdings disseminated by the GES.

Automating the ingestion, processing and visualization of standardized, geospatially-attributed safeguards-relevant information in the GES is a complex and challenging task; but one that will further enhance the ability of imagery and geospatial analysts to deliver insightful, valued analysis to customers. Furthermore, ensuring that users across the Department can readily access the State Infrastructure Analysis Section's extensive library of historical commercial satellite imagery, authoritative geospatially-attributed site plans and imagery-derived analytical products will provide a critical foundation from which the Department can better share and integrate other sources of safeguards-relevant information.

The new two-year plan sees ongoing and potential new support from Member States for seamlessly integrating State-declared information between the Additional Protocol System (APS) and the GES, further evaluating State-declared site maps in a digital, standardized geospatial format under the Digital Declaration Site Maps (DDSM) initiative under MSSP tasks CAN D 1976, FIN D 1996, GER D 1983 and JPN D 1995 (Digital Declaration Site Maps (DDSM) and strengthening the interoperability of the GES with other systems. This work will also be done in collaboration with project SGIS-003: Safeguards Information Systems and System Usability.

5. In-house development tasks

The table below lists internal development activities that will continue, but which will benefit from external contributions to the project. It gives an understanding of how external stakeholders can:

- Complement existing work
- Initiate activities in under-served areas of need
- Avoid duplicate activities

Expected outcome	Task #	Task (Agency's cross reference)	Title task	Description	Expected Completion Date
1	1	Evaluation of new sensor capabilities (2018.03)		SGIM-ISI is working with SGTS-008 on evaluating new and evolving satellite capabilities (for example, PlanetLabs)	Ongoing
1	2	Evaluation of new sensor capabilities (2018.03)		SGIM-ISI is working with commercial vendors on evaluating new and evolving sensor capabilities (Black Sky, Urthecast)	Ongoing

6. Attachments



Figure 28: The State Infrastructure Analysis Section is a multi-disciplinary team including satellite imagery analysts and geospatial analysts working together.

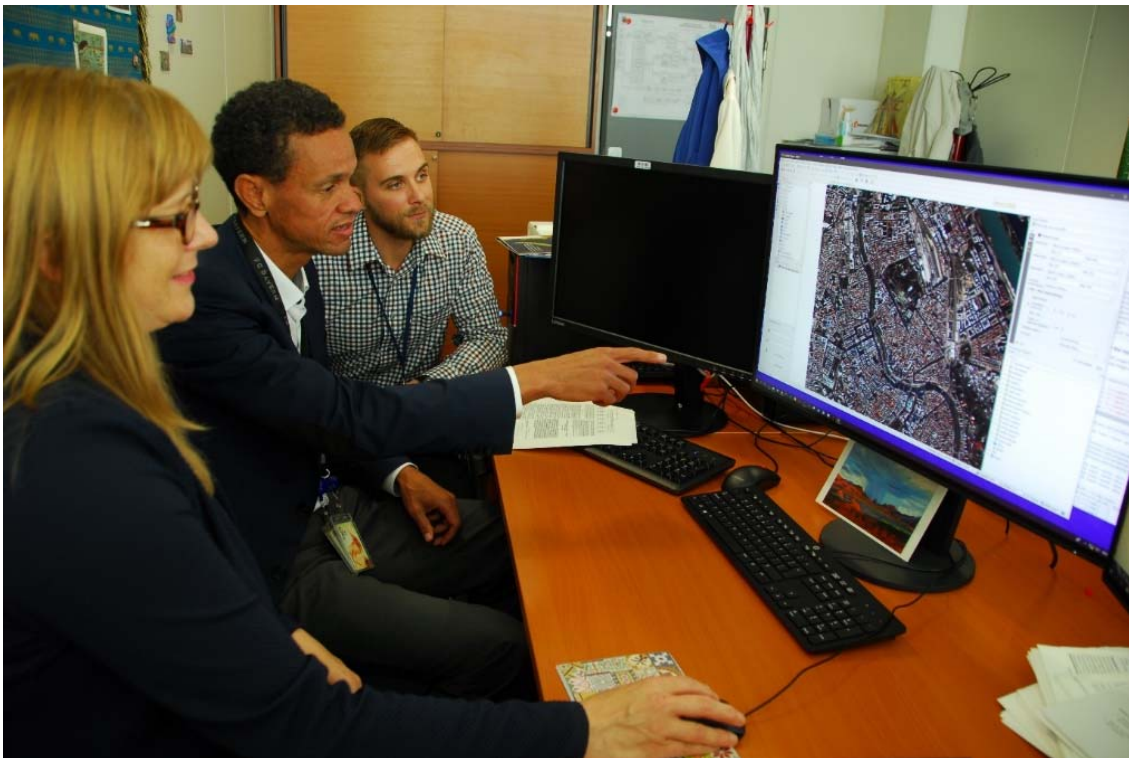

Figure 29: Member States provide the State Infrastructure Analysis Section with expert personnel that have strong technical backgrounds in satellite imagery analysis, geospatial analysis and image processing.

SGIM-003: Information Analysis

Project Manager: Brian AUBERT

1. Overview

Open source information, including trade and procurement data, scientific and technical (S&T) literature and multimedia information is an important element of an effective safeguards system. Open source information is routinely used to verify correctness, completeness and the consistency of State declarations. Integration of safeguards-relevant open source information strengthens the analysis of States' declarations and information resulting from field activities. In particular, open source information is integrated with other available information to assist in the planning of State evaluation activities, both at headquarters and in the field, and can also identify indications of potentially undeclared activities or materials.

This chapter describes plans for further developing methodologies and processes for all parts of the open source information analytical cycle, namely identification, collection, processing, analysis, dissemination and information management. It also guides the development of improved technologies that aid in all steps of the open source information analysis cycle including the analysis of trade and procurement data, scientific and technical publications and multimedia information.

Project objective

Information is available from a wide range of open sources, including international and national news media, commercial databases and websites, government reports and databases, new media sources and S&T literature databases. SGIM-003 focuses on collecting, analysing and integrating information from these disparate sources, to detect possible inconsistencies in States' declarations, in support of the State evaluation process. The rapidly expanding volume of safeguards-relevant information necessitates a continuous process of further development and long-term investment in technology and tools to collect, analyse, organize and present valuable information in a clear and accessible manner.

SGIM-003 will seek to enhance the IAEA's ability to collect and analyse safeguards-relevant information⁵ in support of the IAEA's verification mission, in particular with respect to the State evaluation process and in support of infield verification activities.

Foreseen challenges

Effectively meeting the challenges and opportunities in support of drawing soundly-based safeguards conclusions requires ongoing development and long-term investment in technology, tools and methods that effectively collect relevant open source information, filter out 'noise' and organize safeguards-relevant information in a clear and accessible manner. Other challenges lie in ensuring that the information that already exists in internal databases and archives is used optimally and continues to be fully integrated with other available information. This also requires further development in information management tools and methods.

Constrained resources provide the main challenge to achieving SGIM-003's objectives. The amount of safeguards-relevant information that must be identified, collected, processed, analysed and disseminated continues to grow. The current focus on prioritizing and optimizing sources, tools and methodologies is a reflection of the project responding to the growing workload. Continued extrabudgetary support is therefore key to maintaining a high standard of performance. MSSP support will be directed towards specific areas, including the development of analytical methodologies and capabilities; assistance in diversifying sources; improving the technology and expert tools required and the provision of subject matter experts in relevant nuclear fuel cycle fields.

Top project priorities in 2020–2021

- Develop a capability within the Open Source Information System (OSIS), the current optimized collection system, to provide autonomous browsing of the Internet to identify and return safeguards-relevant information.
- Enhance the automated collection, processing and management of safeguards-relevant open source information in OSIS, including mechanisms for adding structure to unstructured data.

⁵ In accordance with the guidelines described in GOV2014/41.

- In collaboration with project SGIS-003, develop and implement a modern software package, the Technical Assistance Review System (TARS), to facilitate the assessment of potential safeguards-relevant activities and procurements associated with the provision of Agency technical assistance to Member States.
- Optimize the use of multimedia information collection, analysis and integration in State evaluation and preparation for infield activities, through the deployment of specialized tools, methods and procedures.
- Continue to integrate open source datasets with other safeguards-relevant information and systems, including for declared information consistency analysis and infield activity preparation, to enable its use in techniques such as link analysis and geospatial visualization and to develop all necessary use cases and procedures.

2. Strategy framework linkages

IAEA's Programme and Budget project linkage

The plan and MSSP tasks detailed in this chapter are followed-up and/or coordinated by Agency staff and are aligned with the objectives of the Agency's project #4.1.5.004 Information collection and analysis in the *Agency's Programme and Budget 2020–2021*.

Safeguards Research & Development Plan linkage

Priority Objective	R&D Needs
V.1 Strengthen information collection and analysis	V.1.R1 Enhance the set of expert tools necessary to process the variety of SG-relevant information and implement them, with emphasis on timely responses and cost-effectiveness.
	V.1.R2 Make use of new sources of openly available information, including from multimedia, and address the associated information management needs.
	V.1.R3 Further integrate safeguards information to strengthen all-source information analysis and make it more user-friendly.
V.5 Employ fit-for-purpose and state-of-the-art methodologies	V.5.R3 Explore data analysis methods and tools to strengthen State evaluations and synthesize information to improve confidence in the Secretariat's conclusions.

Collaborating D&IS project

- SGIS-003: Safeguards Information Systems and System Usability

3. Progress on expected outcomes, key outputs and tasks from the previous biennium

Expected Outcome #1 from the 2018–2019 Biennium		
Enhanced assessment of nuclear programmes and detection of inconsistencies in States' declarations through the development of optimised tools and methods for the collection, processing, and management of currently utilized safeguards-relevant open source information.		
Supporting R&D Need: V.1.R1		
Key Outputs	Status	Comments
Integration of the European Media Monitor (EMM) as a data source into the OSIS 2.0 system	Key output achieved; work completed	EMM has been fully integrated as a feed to OSIS.
Results of testing of other tools, such as the open source intelligence (OSINT) suite and the Big Table, developed by the Joint Research Centre (JRC)	Key output achieved; work completed	Testing of the OSINT suite and the Big Table is complete. The Big Table has been released for use by trade analysts.

Expected Outcome #1 from the 2018–2019 Biennium

Review and optimization of current open source information search and collection methodologies and techniques	Key output achieved; work continues	This is an ongoing task, as the Department seeks to continually update and improve its methodologies.
---	-------------------------------------	---

Expected Outcome #2 from the 2018–2019 Biennium

Enhanced assessment of nuclear programmes and detection of inconsistencies in States' declarations through the development of optimised tools and processes to update and diversify the pool of safeguards-relevant open source information.

Supporting R&D Need: V.1.R2

Key Outputs	Status	Comments
Development and deployment of tools, methods, and procedures for the optimised use of multimedia information analysis under the SG-Multimedia Project	Key output achieved; work completed	The multimedia team has assembled a suite of forensic and analysis tools to assess a variety of multimedia inputs.
Identification, collection, processing, and integration of information from new safeguards-relevant information sources	Key output achieved; work completed	New information sources in English and other languages have been identified and assessed by open source and trade analysts.
Development and deployment of new tools and methods to optimise the continuous monitoring of new sources of information	Key output achieved; work completed	OSIS has been deployed and is now a common tool used in the Department.

Expected Outcome #3 from the 2018–2019 Biennium

Improved State evaluation process through continuously improved open source information analysis methods and computerized tools to aid the analysis of large amounts of structured, semi-structured, and unstructured data.

Supporting R&D Need: V.5.R3

Key Outputs	Status	Comments
Identification and collection of requirements for a system to enhance the management and analysis of information related to international nuclear cooperation	Key output achieved; work continues	Work is ongoing to better assess the nuclear fuel cycle collaborations that occur internationally. Development of TARS began in 2019. This new system will improve the Department's ability to assess the safeguards relevance of all Agency-supplied technical assistance.
Identification and collection of requirements for tools to enhance the analysis of safeguards-relevant information on trade and industrial capabilities of States, including through the use of data visualization	Key output achieved; work completed	Requirements have been identified for more effective analysis. A new industrial capability assessment methodology has been developed and put into use. A new visualization tool, using a Normalized Revealed Comparative Advantage approach, has been developed and put into use.
Establishment of a documented strategy for utilizing data visualization and network analysis on structured and semi-structured open source information (including trade data)	Key output achieved; work continues	Strategy developed around the use of commercial link analysis tools.

Expected Outcome #3 from the 2018–2019 Biennium

Development, deployment, and enhancement of tools, following above strategy	Key output achieved; work completed	The Department deployed information analysts to more fully exploit the available data using commercial link analysis tools.
Member State peer reviews of tools and methods and reports, consultancies, employment of highly qualified staff, and training to continuously improve the open source analysis methodologies and procedures	Key output achieved; work completed	Member States have provided extensive input to the methodology development, as well as providing significant staffing assistance through JPOs and CFEs.
Training for trade and technology analysis unit	Key output achieved; work completed	A number of familiarisation tours at safeguards-relevant facilities and manufacturers have occurred.

4. Expected outcomes, key outputs and tasks for the 2020–2021 biennium

In order to achieve overall objectives and meet R&D needs, tasks must be initiated, continued and/or finalized during the 2020–2021 biennium. The following expected outcomes serve as an outline for the next 2 years.

Expected outcome #1

Enhanced assessment of nuclear programmes and detection of inconsistencies in States' declarations through the development of optimized tools and methods for the collection, processing and management of currently utilized safeguards-relevant open source information.
Supporting R&D Need: V.1.R1

Key Outputs

Expected Completion Date

A developed capability within the current automatic collection system, OSIS, to provide autonomous browsing of the Internet to identify and return safeguards-relevant information.	December 2020
An enhancement to the automatic collection, processing and management of safeguards-relevant open source information, including mechanisms for adding structure to unstructured data.	December 2021
A review and optimization of current open source information search and collection methodologies and techniques.	December 2021

Plans for accomplishing the expected outcome

The SGIM Global Monitoring Team utilizes open source products, including those developed by the European Commission Joint Research Centre (JRC) at Ispra under MSSP task EC D 1880 (Collection, Analysis and Dissemination of Open Sources) to provide continuous monitoring of news and other open sources. OSIS, which includes JRC-developed products, has been deployed by the IAEA to automate many of the information monitoring, collection and analytic structuring tasks for the Global Monitoring Team and for open source analysts working in State Evaluation Groups. The IAEA will continue to work with the JRC, including further development of tools to support OSIS.

In the 2020–2021 biennium, the project, in collaboration with project SGIS-003: Safeguards Information Systems and System Usability, will seek to complete planned enhancements to tools and methods for collection, processing and management of text-based safeguards-relevant semi-structured and unstructured open source information, to include automatic collection of information from identified sources and mechanisms for adding structure to unstructured data.

Expected outcome #2

Enhanced assessment of nuclear programmes and detection of inconsistencies in States' declarations through the development of optimised tools and processes to update and diversify the pool of safeguards-relevant open source information.

Supporting R&D Need: V.1.R2

Key Outputs	Expected Completion Date
Deployed tools, methods and procedures for the optimised use of multimedia information analysis under the SG-Multimedia Project.	December 2020
Develop and implement a modern software package to facilitate the assessment of potential safeguards-relevant activities and procurements associated with the provision of Agency technical assistance.	July 2020
Enhancement of tools and methods to optimise the continuous monitoring of new sources of information.	December 2021

Plans for accomplishing the expected outcome

In the 2020–2021 biennium, multimedia information analysis, in preparation for infield activities, and its integration in State evaluations, will be used by increasing numbers of State Evaluation Groups. As the capabilities for dealing with multimedia are rapidly evolving, and in collaboration with project SGIS-003: Safeguards Information Systems and System Usability, continued MSSP support will be required for tool assessment, development of use cases, methodologies, procedures, training materials and expert support in multimedia analysis (for example, MSSP task USA D 1126 (Consultant - Assistance on Information Collection and Information Systems)).

The IAEA seeks to ensure the broadest possible set of sources of safeguards-relevant information to support the drawing of safeguards conclusions. Such work has been ongoing for over a decade and will remain essential during 2020–2021. An increased emphasis on access to regional scientific and technical information brings the challenge of identifying and translating safeguards-relevant non-English language information. Some MSSPs already provide support to this activity, namely under MSSP tasks UK D 1728 (Regional Information Collection Centre-East Asia), UK D 1730 (Regional Information Collection Centre-Middle East) and ROK D 1213 (Provision of Open Source Information) whilst others support the retrieval of information from new media under RSA D 1489 (Open Source Information Collection).

Additionally, a number of sources for trade and procurement data have been identified and evaluated for Departmental use. Support is needed to continue this process through MSSP tasks EC D 1662 (Improving Analysis of Covert Nuclear Trade), UK D 1916 (Improving the Analysis of Trade Data for Safeguards Relevant Proliferation Activities) and HUN D 1919 (Collection and Analysis of Nuclear Trade Related Information to Strengthen Safeguards).

In addition to a continuation of current support, assistance from Member States may be sought to expand the number of sources; of both non-English language information and trade and procurement data.

The goal is to continue to:

- Develop optimized tools and processes to identify new sources and types of data.
- Include new text-based information sources, multimedia information and trade data.
- Enable the efficient collection, processing, analysis, integration and management of this data.

Expected outcome #3	
Improved State evaluation process through continuously improved open source information analysis methods and computerized tools to aid the analysis of large amounts of structured, semi-structured and unstructured data.	
Supporting R&D Need: V.5.R3	
Key Outputs	Expected Completion Date
Deployed tools such as the Big Table, developed in conjunction with JRC, to enhance the analysis of safeguards-relevant information on trade and industrial capabilities of States, including through the use of data visualization.	December 2020
Utilization of data visualization and network analysis on structured and semi-structured open source information (including trade data).	July 2020

Development, deployment and enhancement of any additional tools, following above strategy. Ongoing

Training for trade and technology analysis teams.

At least one per year

Plans for accomplishing the expected outcome

Open source analysis methods and tools used to facilitate the drawing of credible safeguards conclusions need to be continually improved. This includes enhancing the analysis of technical information and large quantities of data (structured, semi-structured and unstructured) in order to detect signatures of possible undeclared activity; improve analysis of nuclear fuel cycles and activities possibly related to weaponization and support the State evaluation process, including the development of acquisition path analysis (APA) and State Level Approaches (SLAs).

New tools and methods for enhanced analysis of safeguards-relevant information on trade and industrial capabilities are required for the State evaluation process, to support the development of APAs and SLAs, to analyse State declarations consistently and to detect potential indicators of undeclared activities.

Tools already developed in collaboration with the JRC through MSSP task EC D 1662 (Improving Analysis of Nuclear Trade-Related Information), such as the Big Table (TBT) and Normalized Revealed Comparative Advantage methodology, will be used to support trade and industrial capabilities assessment activities.

In order to provide comprehensive, pertinent analysis of safeguards-relevant information to State Evaluation Groups, analytical methodologies, tools and techniques must be further developed and refined with a particular focus on the use of trade and procurement data. Training in support of such analysis through MSSP task GER B 1560 (Nuclear Trade Analysis Related Support and Training for Trade and Technology Analysis Unit) has proven effective in raising the competence levels of analysts and will be continued.

New methodologies that assist the analysis of large, disparate datasets through link analysis and visualization will be developed for safeguards, spanning the entire range of analytical activity from the classification of information sources to efficient and effective information retrieval. A new initiative in this biennium involves the deployment of a number of information analysts to more fully exploit the data available to the Department with commercial link analysis tools.

The identification and collection of requirements for the tools and methods associated with effectively utilizing open source information originates in SGIM, with collaboration from the Operations divisions and other users. Following these requirements, SGIS develops and deploys the majority of required software applications. Specific expert software tools are also developed in SGIM. For the development of information systems running on the departmental platforms, the collaboration between SGIM and SGIS is essential to ensure user satisfaction, compatibility and maintainability of systems that will facilitate the integration of safeguards data.

Inputs from specialized technical consultants also play a significant role in enhancing the Department's capability to evaluate new technologies and complex issues. Provision of consultants with extensive experience in particular aspects of open source analysis through MSSP tasks USA D 1126 (Consultant - Assistance on Information Collection and Information Systems), UK D 1819 (Nuclear Fuel Cycle Specialist Assistance), AUL D 1915 (Consultant - Assistance on Information Collection and Analysis) and EC D 1880 (Collection, Analysis and Dissemination of Open Sources)—allows the Agency to provide a broader and deeper range of high-quality analytical products. In addition, the opportunity to interact with outside experts enables information analysts to improve their knowledge of analytical approaches and technical issues. A number of technical conferences, trade fairs and safeguards-relevant manufacturing facilities will be visited for this purpose. Member State support in this regard remains indispensable.

Expected outcome #4	
Improved integration of open source information in 'all source' information analysis, contributing towards collaborative analysis. Supporting R&D Need: V.1.R3	
Key Outputs	Expected Completion Date
Integration of open source information collections with Integrated Safeguards Environment (ISE) State Files, commercial link analysis software and other applications.	July 2021
Integrate a commercial reference manager with commercial link analysis software to facilitate structuring of science and technology information.	July 2021

Plans for accomplishing the expected outcome

The Department-wide dissemination of open source information in the OS Library, in the Integrated Safeguards Environment (ISE) and in the Open Source Highlights daily newsletter maintains ongoing awareness of safeguards and non-proliferation developments and issues. The accumulation of safeguards-relevant information also provides a historical archive that is utilized to better assess the development of activities relevant to safeguards with regard to States' legal obligations with the Agency.

It is increasingly necessary to optimize the integration of open source information into tools and methods for 'all source analysis' in order to detect possible signatures of undeclared activity; to improve analysis of nuclear fuel cycles and activities possibly related to weaponization and to support the State evaluation process and draw credible safeguards conclusions. Work will continue, to integrate open source datasets with other safeguards-relevant information and systems, including information and systems for declared information consistency analysis and infield activity preparation. Work will also continue to develop use cases and procedures tailored to safeguards needs, enabling their use in tools and techniques (including link analysis and geospatial and other visualizations) in support of collaborative analysis in the Department.

Analysis of scientific and technical literature can provide indications of undeclared nuclear activity, as well as additional assurance on the correctness and completeness of States' declarations. To that end, a commercial reference management software package will be modified to more easily import structured science and technology articles into commercial link analysis software. This will allow for more efficient review of the correctness and completeness of State declarations.

This project will continue to collaborate closely with SGIS-003: Safeguards Information Systems and System Usability to further structure and integrate its open source information collections into other departmental systems, including (but not limited to) ISE State Files, commercial link analysis software and other applications.

5. In-house development tasks

The table below lists internal development activities that will continue, but which will benefit from external contributions to the project. It gives an understanding of how external stakeholders can:

- Complement existing work
- Initiate activities in under-served areas of need
- Avoid duplicate activities

Expected outcome	Task #	Task Title (Agency's task cross reference)	Description	Expected Completion Date
1	1	Text-based automation (2018.04) OS	Continue enhancement of OSIS and other tools and methods to collect, process, and manage text-based safeguards-relevant semi-structured and unstructured open source information, to include automated collection of information from identified sources, and mechanisms for adding structure to unstructured data.	December 2021

1	2	Search and collection (2018.04)	Review and optimize current open source information search and collection methodologies and techniques, including developing and deploying any necessary tools.	July 2021
2	3	Multimedia analysis (2018.04)	Broaden the use of multimedia information analysis and integration in State evaluation and preparation for infield activities, through the development and deployment of tools, methods, and procedures.	December 2020
2	4	New OS sources (2018.04)	Continue to identify and collect information from new safeguards-relevant information sources, and develop and deploy new tools and methods to optimize the continuous monitoring of such sources of information	December 2021
3	5	Transactional-based trade data (2018.04)	Work with the MSSPs to obtain additional transactional-based trade datasets for the evaluation of dual use technologies and assessment of industrial capabilities.	December 2020
3	6	Trade and industrial infrastructure tools (2018.04)	Deploy tools and methods to enhance the analysis of safeguards-relevant information on trade and industrial capabilities of States, including the use of data visualization.	July 2020
3	7	Visualization and network analysis (2018.04)	Develop strategy for utilizing data visualization and network analysis on structured and semi-structured open source information (including trade data); develop and enhance tools as necessary.	December 2021
4	8	Information integration (2018.04)	Continue to work to integrate open source datasets with other safeguards information and systems, including for declared information consistency analysis and infield activity preparation, to enable its use in techniques including link analysis, and geospatial and other visualizations, and to develop all necessary use cases and procedures, tailored to SG needs, contributing towards collaborative analysis in the Department.	Ongoing

6. Attachments

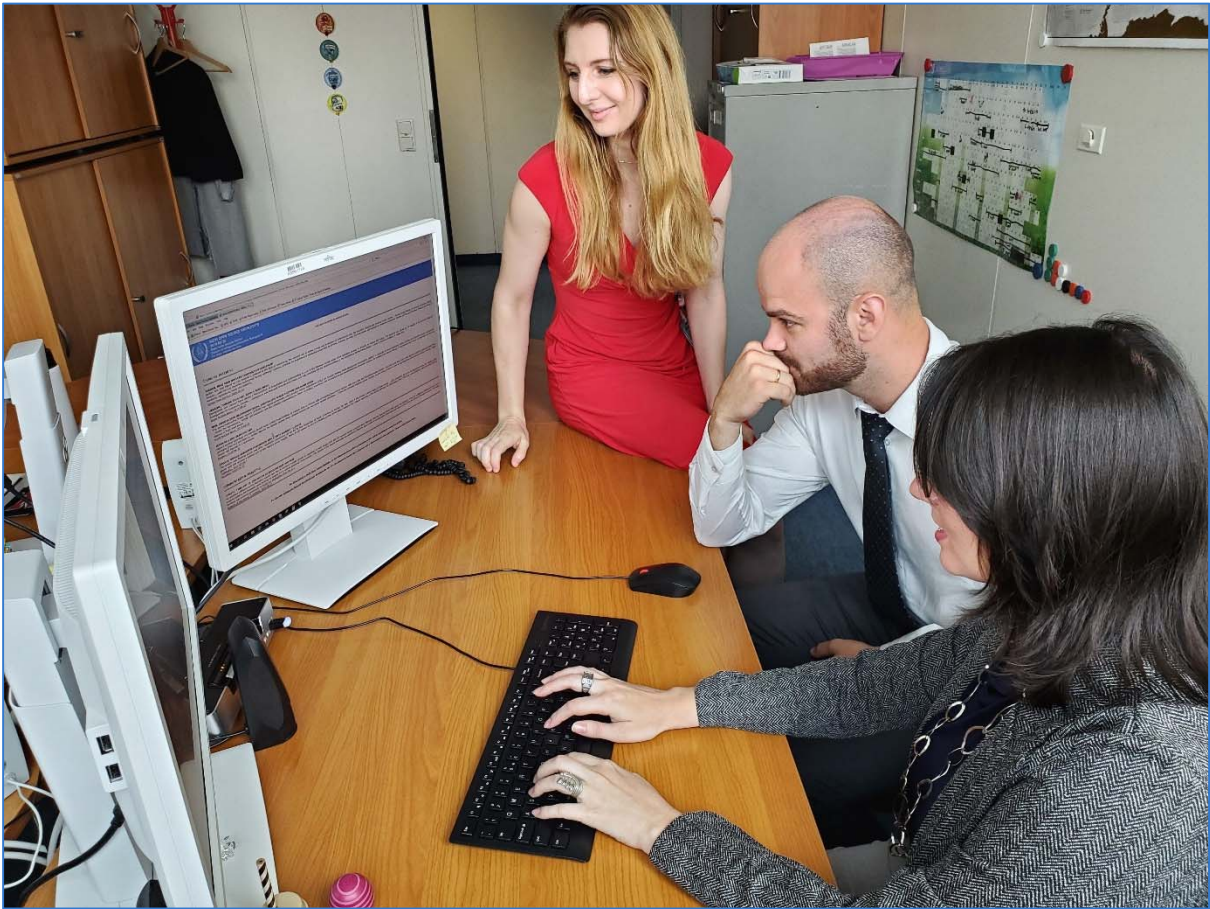

Figure 1: Junior Professional Officers (JPOs) reviewing the daily open source collection as part of the Global Monitoring Team.

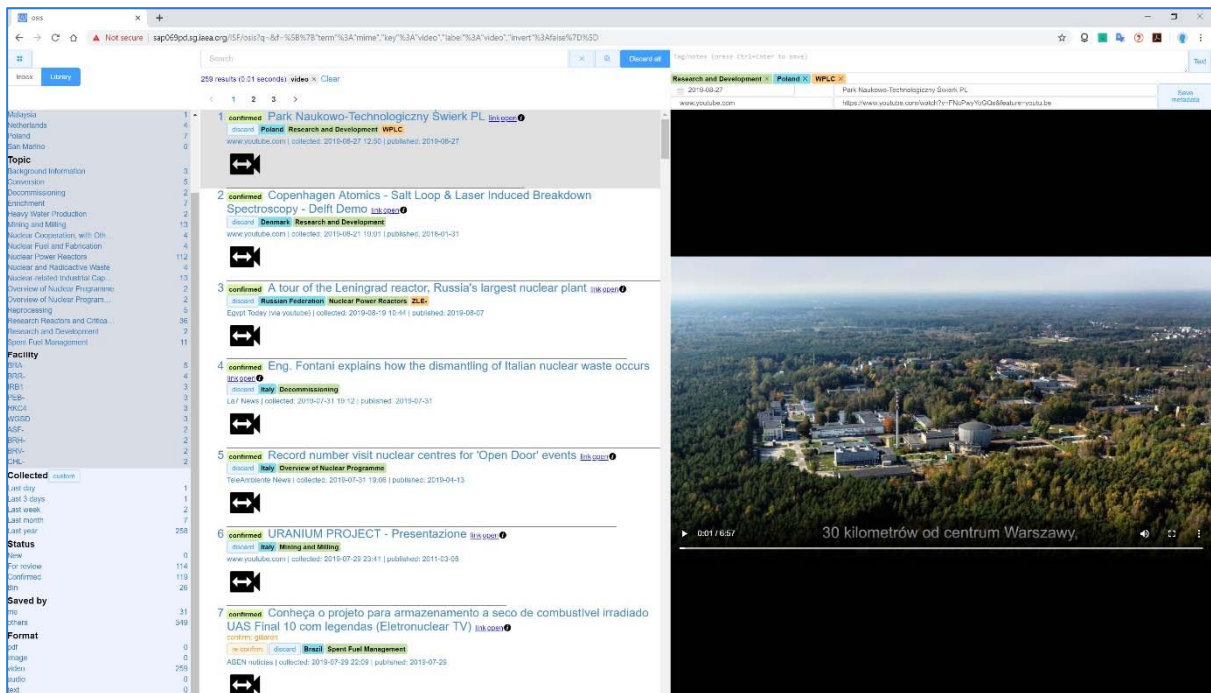

Figure 30: Open Source Information System (OSIS) user interface

SGIM-007: Evaluation of Data from Environmental Sampling and Material Characterisation

Project Manager: Mika NIKKINEN

1. Overview

This chapter describes the plans for developing and implementing new capabilities to assess the results from environmental sampling (ES) and characterisation of uranium materials during the 2020–2021 biennium.

Project objective

The overall objective is to enhance the IAEA's ability to structure, organize, evaluate, interpret and present data from ES and material characterisation in support of the IAEA's verification mission. In particular, the aim is to reinforce capabilities for the detection of undeclared nuclear material and activities.

Foreseen challenges

Proliferators are likely to challenge the IAEA safeguards verification system by adopting methods aimed at evading detection through ES. Therefore, all aspects of ES and material characterisation planning, implementation and evaluation require continual improvement to advance verification capability and reliability. This includes investigating sampling strategies, improving sampling methods, processing and evaluating sample-related information and laboratory analysis results, modelling nuclear fuel cycle (NFC) processes and weighing the quality control of the entire ES process.

A second challenge is maintaining continuity of knowledge and best practice for evaluating ES data. One of the keys to maintaining the continuity of knowledge is the ES database (ESDB), which houses all current and historic measurement data from the ES programme, including the contextual information such as sampling description, dates, locations, expected signatures, laboratory notes and evaluation summaries. Over the next two years, the ESDB software will need to be migrated to the latest version because the developer will no longer support the current version. In addition, updates to the ESDB structure, forms and reports are warranted due to the introduction of new data strings for uranium age-dating of particles and statistical evaluations.

Top project priorities in 2020–2021

- Explore and develop statistical techniques and evaluation methodologies that improve data evaluation and the application of signatures detectable through ES and material characterisation, including the use of elemental and morphological data.
- Expand current understanding of the detectable signatures (isotopic, elemental and morphological characteristics of key materials) from NFC activities, including the formation, transport and transformation of particles in the environment.
- Complete the migration of the ESDB to Oracle 12c.

2. Strategy framework linkages

IAEA's Programme and Budget project linkage

The plan and MSSP tasks detailed in this chapter are followed-up and/or coordinated by Agency staff and are aligned with the objectives of the Agency's project #4.1.5.02 Nuclear fuel cycle information analysis in the *Agency's Programme and Budget 2020–2021*.

Safeguards Research & Development Plan linkage

Priority Objective		R&D Needs	
T.3	Support all SG processes through IT	T.3.R4	Maintain and continue to upgrade the environmental sampling database and the process modelling tools as well as the database and tools that support trace element analysis (material characterisation).
V.5	Employ fit-for-purpose and state-of-the-art methodologies	V.5.R1	Upgrade existing and develop new statistical methodologies applied to the: Evaluation of quantitative and qualitative verification data including at the State level (e.g., for nuclear material balance evaluation, random inspections) Measurement of verification performance (in terms of detection probability) and the associated level of confidence at the facility and State level Design of random verification schemes (minimizing resources for the same level of effectiveness).
		V.5.R2	Strengthen knowledge of the elemental and isotopic signatures of the nuclear fuel cycle and processes that are specifically detectable through material characterisation and environmental sample analyses, and develop expert systems and methodologies that advance data evaluation and enhance continuity of knowledge.

Collaborating D&IS projects

- SGAS-002: Environmental Sample Analysis Techniques
- SGAS-003: Analysis Support and NWAL Coordination
- SGIS-003: Safeguards Information Systems and System Usability

3. Progress on expected outcomes, key outputs and tasks from previous biennium

Expected Outcome #1 from the 2018–2019 Biennium		
<p>Developed elemental and isotopic signatures of nuclear fuel cycle activities and processes (for example, uranium conversion and laser enrichment), and their application to the analysis of environmental sampling and destructive analysis of nuclear material using mathematical, statistical and graphical tools.</p> <p>Supporting R&D Need: V.5.R2</p> <p>The IAEA seeks to expand its understanding of the detectable signatures (isotopic, elemental, and morphological characteristics of key materials) of nuclear fuel cycle activities, including the formation, fate and transport of particles in the environment.</p>		
Key Outputs	Status	Comments
Collection of uranium impurity data and fuel burn-up inventories obtained from studies completed by Member States for integration into existing SGIM-IFC evaluation libraries	Key output achieved; work continues	<ul style="list-style-type: none"> • Completed: • Uranium ore concentrate (UOC) impurity data and the final report from the Springfields project. • Reactor modelling to generate several fuel burn-up libraries. <p>Ongoing: Impurity analysis of UOC from Czech site.</p> <p>Note: this was completed in 2nd half of 2017, but was included in 2018–2019 plan.</p>
Release of upgraded MSTAR12 cascade modelling software to include side streams	Key output achieved; work continues	A complete version of MSTAR was delivered November 2019. Minor changes were proposed, and code and documentation

Development of beta software for alCHEMy, evaluation software for cross referencing isotopic and elemental data with nuclear fuel cycle (physical model) signatures

Delayed; work in progress

were reviewed and finalized in December 2019. The code functions as expected.

The latest developments were presented at the NWAL technical meeting in November 2019, which included a programming solution using Python. The alCHEMy method was well received by the NWAL consultants.

Expected Outcome #2 from the 2018–2019 Biennium

Developed statistical methodologies and mathematically-based approaches to optimize safeguards verification approaches and evaluation of results.

Supporting R&D Need: V.5.R1

The IAEA seeks to explore and develop statistical techniques and evaluation methodologies that improve data evaluation and the understanding of signatures observable through environmental sampling and material characterisation, including the use of elemental and morphological data.

Key Outputs	Status	Comments
Deployment of the DAVE software for evaluation of trace element and isotopic signatures in uranium samples.	Key output achieved; work continues	DAVE software was delivered in Q4 2018, but IT security policies disable many features, which impeded the acceptance testing. User testing identified some areas to address. The developers are working to resolve these issues. Expected acceptance is March 2020.
Deployment of the INDEPTH software for identifying fuel burn-up, starting enrichments and cool down times.	Key output achieved; work completed	INDEPTH software and SCALE software licenses received and implemented.
Release of customized Visual Sampling Plan (VSP) software for providing detection/non-detection confidence levels.	Key output achieved; work continues	The first phase of developing statistical approaches with Lawrence Livermore National Laboratory is complete. VSP task is in progress.

Expected Outcome #3 from the 2018–2019 Biennium

Maintained and upgraded ES Evaluation software tools and applications to meet future safeguards information technology requirements and ensure no loss of service.

Supporting R&D Need: T.3.R4

The IAEA seeks to ensure the ES evaluation tools are compatible with the Department's migration to new operating systems and computer architecture, therefore software and applications must be validated and incompatibilities remedied.

Key Outputs	Status	Comments
Release of software upgrades related to the new information landscape and validation testing of all ES evaluation software, in preparation of the transition to 64-bit personal computers using Windows 10.	Key output achieved; work completed	Migration of ES software to Windows 10 completed March 2019.

4. Expected outcomes, key outputs and tasks for 2020–2021 biennium

In order to achieve overall objectives and meet R&D needs, tasks must be initiated, continued and/or finalized during the 2020–2021 biennium. The following expected outcomes serve as an outline for the next 2 years.

Expected outcome #1	
Improved understanding of elemental and isotopic signatures of NFC activities and processes (for example, uranium conversion, reprocessing and laser enrichment).	
Expanded understanding of detectable signatures of NFC activities (isotopic, elemental and morphological characteristics of key materials), including the formation, transport and transformation of particles in the environment and improved methods for the collection of such material through ES.	
Supporting R&D Need: V.5.R2	
Key Outputs	Expected Completion Date
Collection of uranium impurity data and fuel burn-up inventories obtained from studies completed by Member States for integration into existing SGIM-IFC evaluation libraries.	December 2021
Development of beta software for alCHEMy, evaluation software for cross referencing isotopic and elemental data with NFC (Physical Model) signatures.	December 2021
Initiated studies for developing alternate sampling methods and media for more effective particulate collection.	December 2020

Plans for accomplishing the expected outcome

The IAEA will continue to look for opportunities to expand the reference database related to NFC elemental and isotopic signatures. Such reference data bolsters the ES data analysts' ability to evaluate ES data by providing comparative data, thereby improving confidence in evaluation conclusions. Tasks that will extend reference data for various nuclear signatures include:

Expansion of the library of radionuclide inventories based on WIMSD calculations that model reactor irradiation scenarios for multiple reactor designs and fuel configurations under MSSP task UK A 1853 (WIMSD Reactor Calculations).

Continuation of the investigation of uranium trace-elemental signatures under MSSP tasks EC A 1753, BRZ A 1766 and CZ A 2223 (Experimental Investigation of Behaviour of Trace Elements in Uranium during the Concentration and Conversion Processes). UOC samples collected from a plant in the Czech Republic are undergoing analysis. The reporting and evaluation of the results are expected to be completed during 2020–2021. Further support from MSSPs will be sought to investigate and expand the Agency's understanding of NFC elemental and isotopic signatures.

A major ongoing study, alCHEMy, involving the evaluation of elemental signatures related to the NFC, is intended to continue. A major study, alCHEMy, involves evaluating elemental signatures related to the NFC. The ongoing work will include establishing a reference database of elements and chemical compounds associated with NFC activities. An application is being developed to cross-reference the reference database with large datasets of ES elemental and isotopic particle data, to aid in identifying material combinations associated with nuclear activities. Once established, alCHEMy will provide a systematic and sustainable approach to evaluating elemental data.

The development of new and existing sampling and analysis approaches will be explored through technical meetings and inter-laboratory comparisons with the network laboratories for ES, in conjunction with SGAS-003: Analysis Support and NWAL Coordination and SGIS-003: Safeguards Information Systems and System Usability. Because the IAEA also seeks to expand its understanding of the detectable signatures, including the various elemental compositions, one of the proposed inter-laboratory comparisons will focus on elemental characterisation of particles collected on a swipe.

Expected outcome #2

Optimized evaluation of ES results and improved safeguards verification.

Supporting R&D Need: V.5.R1

Key Outputs

Expected Completion Date

Statistical approaches to evaluate particle data from enrichment facilities have been explored.	December 2021
Visual Sampling Plan software for providing detection/non-detection confidence levels of ES results has been assessed.	December 2020

Plans for accomplishing the expected outcome

The IAEA seeks to explore and develop statistical techniques and evaluation methodologies that improve data evaluation and the understanding of signatures observable through ES and material characterisation, including the use of elemental and morphological data.

The IAEA also seeks to investigate Bayesian statistical techniques to assess detection and/or confidence levels for ES through the use of software called Visual Sampling Plan (VSP) (US A 2306). If proven to be suitable for IAEA use with respect to ES, and in collaboration with project SGIS-003: Safeguards Information Systems and System Usability, the VSP software could be used to quantify a confidence level for ES evaluation conclusions. Other statistical approaches are being explored to evaluate cumulative particle data from enrichment plants (US D 2447). The goal of such development is to better understand the operational signatures of an enrichment plant and more accurately identify ES results that fall outside of expected operations.

Expected outcome #3

Continuity of knowledge and best practices in data evaluation is maintained.

Supporting R&D Need: T.3.R4

Key Outputs

Expected Completion Date

ESDB is migrated to Oracle 12c.	December 2020
ESDB accepts measurement data associated with age-dating of uranium particles.	December 2020
Best practices for ES evaluations are documented.	December 2021

Plans for accomplishing the expected outcome

The IAEA seeks to adapt the ESDB structure, user interface and output to accommodate data from new analytical techniques, newly developed evaluation methods and hardware/software updates.

The IAEA relies on its customized database, software applications and modelling algorithms to maintain continuity of knowledge and best practices for evaluating ES data. By the end of 2020, the current version of the Oracle database software will no longer be supported by its vendor and must be updated to a newer version (Oracle 12c.) and also to facilitate exchange of information with SGAS data management systems. This is a major upgrade, and the supporting database-related user interface, summaries and outputs will have to be re-validated under MSSP task USA A 1498 (Environmental Sampling Evaluation Support) and in collaboration with project SGIS-003: Safeguards Information Systems and System Usability. At the same time, the database structure will be expanded to accommodate data from newly-developed analytical techniques (for uranium age-dating of particles and compound identification) and evaluation methods using machine learning also through MSSP task USA A 1498.

5. In-house development tasks

The table below lists internal development activities that will continue, but which will benefit from external contributions to the project. It gives an understanding of how external stakeholders can:

- Complement existing work
- Initiate activities in under-served areas of need
- Avoid duplicate activities

Expected outcome	Task #	Task Title (Agency's task cross reference)	Description	Expected Completion Date
1	1	2020 Technical Meeting on Bulk Analysis for Environmental Sampling	Biennial meeting with network laboratories involved with ES bulk analysis, to discuss current and future developments and to draft recommendations for future actions. Organized by SGAS in cooperation and coordination with SGIM.	December 2020
1	2	Inter-laboratory comparison on High Resolution Gamma Spectrometry (HRGS) analysis of ES swipe samples	Assist in developing the objectives and evaluating the results from the inter-laboratory exercise to compare laboratory performance of HRGS analysis of common samples (QC swipe samples). Organized by SGAS in cooperation and coordination with SGIM.	June 2021
1	3	2021 Technical Meeting on Particle Analysis for Environmental Sampling	Biennial meeting with network laboratories involved with ES particle analysis, to discuss current and future developments and to draft recommendations for future actions. Organized by SGAS in coordination and coordination with SGIM.	November 2021
1	4	Inter-laboratory comparison on elemental characterisation of particles collected on a swipe by scanning electron microscopy (SEM).	Assist in developing the objectives and evaluating the results from the first SEM inter-laboratory comparison for particle analysis. Organized by SGAS in cooperation and coordination with SGIM.	November 2021
1	5	Inter-laboratory comparison on bulk analysis of environmental sample swipes.	Assist in developing the objectives and evaluating the results from inter-laboratory comparison on ES bulk analysis. Organized by SGAS in cooperation and coordination with SGIM.	December 2020
1	6	Inter-laboratory comparison on particle analysis of environmental sample swipes.	Provide user requirements and assist in setting exercise objectives for the inter-laboratory comparison on ES particle analysis. Organized by SGAS in cooperation and coordination with SGIM.	November 2021
1	7	Inter-laboratory comparison on determination of elemental	Provide user requirements and assist in setting exercise objectives for the inter-laboratory comparison on impurity analysis. Organized by	December 2021, subject to

		impurities in uranium oxide matrix materials	SGAS in cooperation and coordination with SGIM.	availability of resources.
1	8	Study of elemental signatures and optimization of aLChEMy	Using the aLChEMy reference database and data visualization functions, elemental data from known facilities will be evaluated in order to optimize methodologies, determine analytical needs and complete sensitivity studies.	December 2021
2	9	Expansion of functionality of ENVISDA (2018.02)	ENVISDA is an ES Evaluator tool to aid in evaluation of data and generation of reports. Development will continue to expand functionality, including interactive features.	June 2020
2	10	Investigate the inclusion of the ES findings into the Geo-based Data Integration (GDI) system	Coordinate with Operation Divisions to identify the ES-related information that would be useful to include in the GDI. Develop implementation plan and requirements, as well as identify any system barriers to linking the ESDB with the GDI.	December 2021

6. Attachments

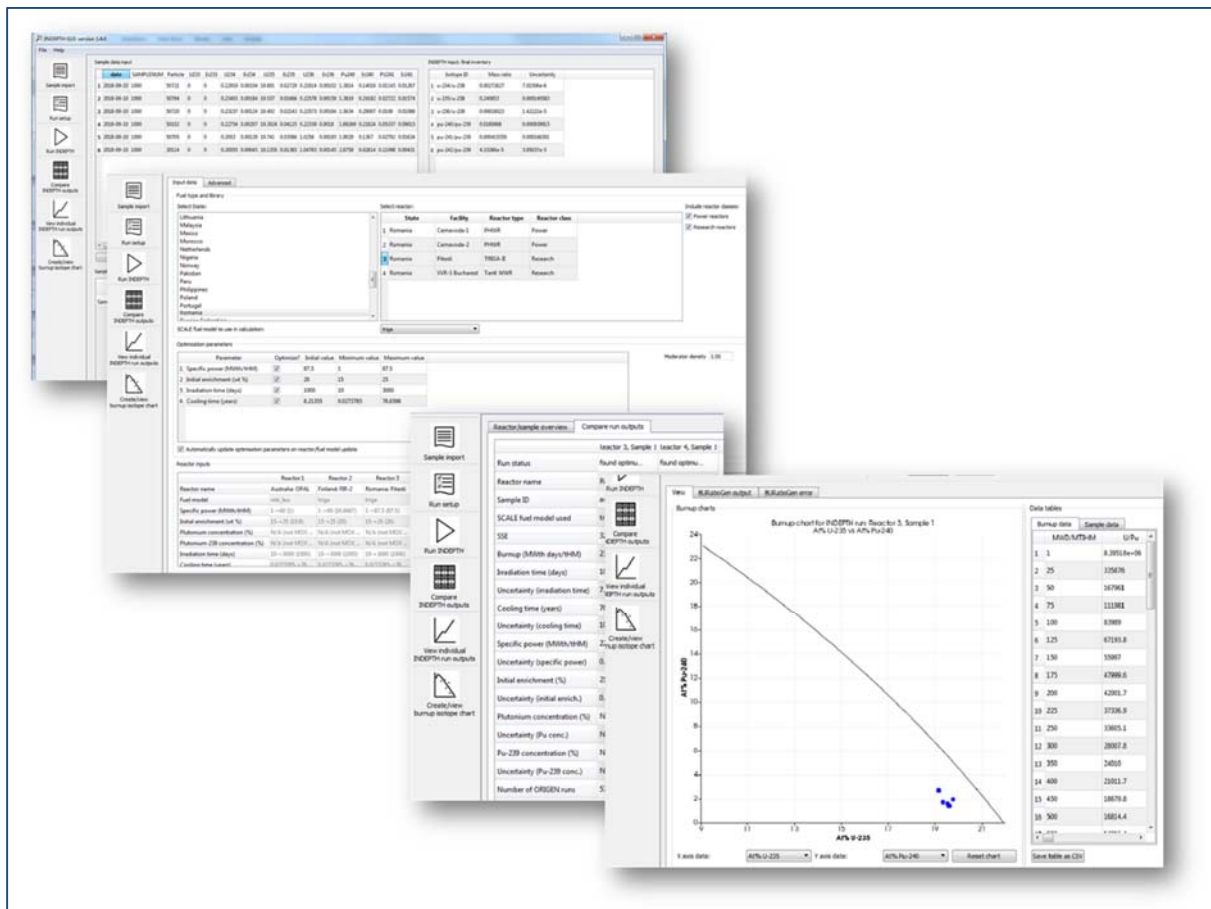

Figure 31: Screen shots of a run of INDEPTH, a reverse fuel burn-up code, used for identifying the origin of irradiated uranium particles.

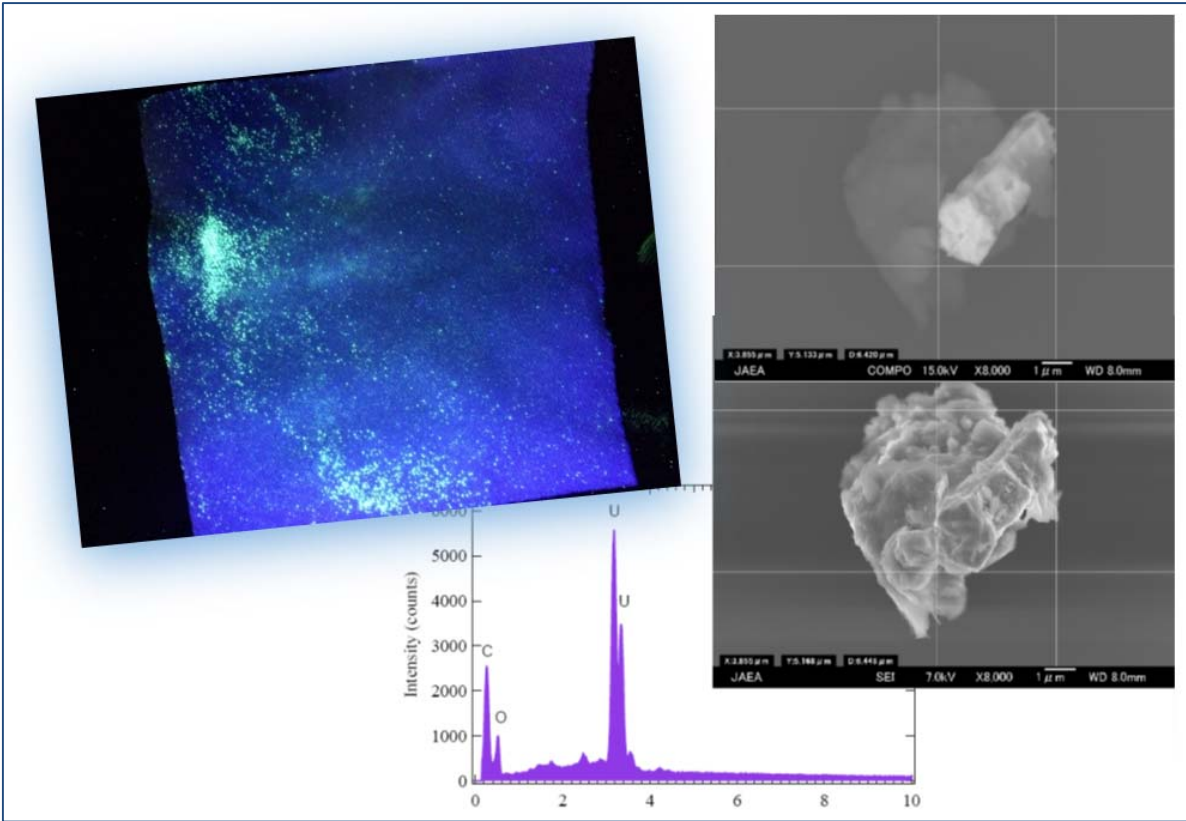

Figure 32: A swipe with florescent particles is shown to simulate an ES collection. Through sensitive analysis techniques, micron-sized particles can be isolated and measured.

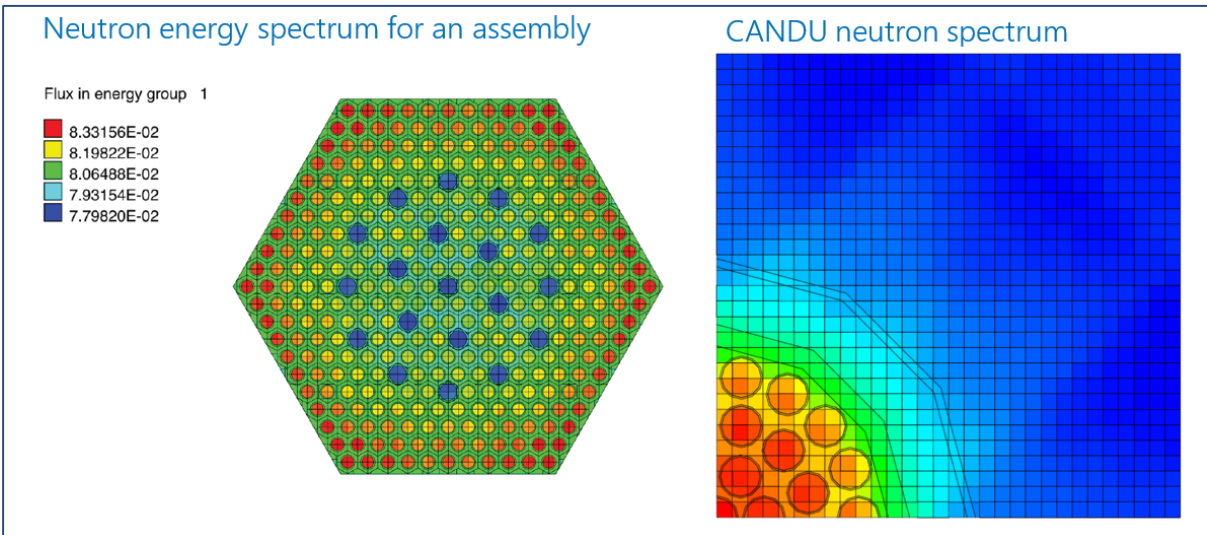

Figure 33: Reactor modelling examples for determining fuel burn-up for comparison to ES analytical results.

SGIM-008: Statistical Analysis

Project Manager: Robert BINNER

1. Overview

This chapter describes the plans for developing and implementing statistical methodologies during the 2020–2021 biennium to support the design and evaluation of safeguards approaches, inspection activities and related data and the optimization of resources.

Project objective

The overall objective is to support the Department's design, implementation and evaluation of safeguards approaches and related verification activities by developing statistical and probabilistic methodologies. This includes further enhancement of data visualization tools and the development and enhancement of statistical methodologies in support of:

- State Level Approaches
- Random inspection schemes
- Material balance evaluation (MBE)
- Inspection/verification activities, including sample size calculation
- Uncertainty quantification (UQ)
- Near Real-Time Accountancy (NRTA)
- State-declared information analysis

Foreseen challenges

The development of statistical methodologies for safeguards is a highly specialized field, requiring a combination of skillsets that traditionally has been in short supply. An in-depth familiarity with safeguards is required, combined with expertise in statistics, in order to effectively contribute to this task.

The Department's own resources, specialized in these fields, are required to prioritize the statistical evaluation activities that contribute to the implementation of safeguards. Devoting significant in-house effort towards development activities is therefore very challenging. For this reason, it is essential that:

- Support from CFEs and JPOs is maintained to sustain a 'critical mass' of experts working in close collaboration to deliver both development and implementation tasks
- External support remains available, to help address both specific, well-defined and potentially short-term technical and financial development needs; and also those needs that may require longer-term support and greater continuity of knowledge or experience of safeguards

Without both components of this support, the Department's essential development needs in statistical methodologies cannot be met.

Top project priorities in 2020–2021

- Standardized methodologies, in support of State Level Approaches, for calculating detection probabilities achieved through verification activities, at both facility and State levels. The aim here would be to support the determination of frequencies and intensities of quantitative verification activities and to evaluate their effectiveness.
- Improved and harmonized random inspection schemes (including short notice random inspections (SNRIs)) and methodologies developed to evaluate their effectiveness.
- Further development of sampling methodologies and practical implementation procedures for these methodologies.
- Further enhancement of software and visualization tools to support the design, implementation and evaluation of safeguards approaches and related verification activities.

2. Strategy framework linkage

IAEA's Programme and Budget project linkage

The plan and MSSP tasks detailed in this chapter are followed-up and/or coordinated by Agency staff and are aligned with the objectives of the Agency's project #4.1.5.002 Nuclear fuel cycle information analysis in the *Agency's Programme and Budget 2020–2021*.

Safeguards Research & Development Plan linkage

Priority Objective		R&D Needs	
T.3	Support all SG processes through IT	T.3.R2	As part of STEPS (Statistical Evaluation Platform for Safeguards) project, re-engineer and integrate all the legacy systems used for the statistical evaluation of State declared and verification data and the probabilistic calculations that inform verification approaches (e.g., sampling plans and random inspection schemes).
V.4	Enhance SG effectiveness monitoring and evaluation	V.4.R1	Identify and deploy analytical tools, including data visualization, to better measure and analyse performance and take advantage of capabilities provided by MOSAIC.
V.5	Employ fit-for-purpose and state-of-the-art methodologies	V.5.R1	Upgrade existing and develop new statistical methodologies applied to the: <ul style="list-style-type: none"> • Evaluation of quantitative and qualitative verification data including at the State level (e.g., for nuclear material balance evaluation, random inspections) • Measurement of verification performance (in terms of detection probability) and the associated level of confidence at the facility and State level • Design of random verification schemes (minimizing resources for the same level of effectiveness).
		V.5.R3	Explore data analysis methods and tools to strengthen the synthesis and evaluation of information (e.g., optimal random verification schemes, nuclear material flow analysis, material balance evaluation, near real-time accountancy and process monitoring tools).

Collaborating D&IS projects

- SGCP-003: Safeguards Approaches
- SGIS-003: Safeguards Information Systems and System Usability
- SGIM-007: Evaluation of Data from Environmental Sampling and Material Characterisation

3. Progress on expected outcomes, key outputs and tasks from the previous biennium

Expected Outcome #1 from the 2018–2019 Biennium		
Reviewed, updated and consolidated algorithms for the determination of measurement error uncertainties from operator-inspector paired-data, 3-laboratory data, and calibration data.		
Supporting R&D Need: V.5.R3		
Key Outputs	Status	Comments
STR on the uncertainty quantification (UQ) methodologies used as a basis for UQ methods applied to safeguards verification data.	Key output achieved; work continues	A Safeguards Technical Report (STR) on UQ was drafted though MSSP task USA A 1989 (Expert - Statistical and Probabilistic Methodologies for Inspection Approaches and Verification Result Analysis). Peer review of the document is ongoing with the final version expected to be published in 2020.

Expected Outcome #2 from the 2018–2019 Biennium

Reviewed, updated and consolidated methodologies applied to the evaluation of MUF, D, IMUF and SRD in the context of material balance evaluation.

Supporting R&D Need: T.3.R2

Key Outputs	Status	Comments
Technical document (most likely an STR) on the methodologies and implementation of the methodologies in relevant analytical software.	Key output achieved; work continues	Enhanced methodologies for evaluating MBE statistics were developed and are being implemented in the MBE module of STEPS (Statistical Evaluation Platform for Safeguards). Methodologies will be comprehensively documented in an STR as part of the STEPS development.

Expected Outcome #3 from the 2018–2019 Biennium

Further developed sampling methodologies described in STR-381 and practical implementation procedures for these methodologies.

Supporting R&D Need: V.5.R1

Key Outputs	Status	Comments
Practical implementation procedures for inclusion in the inspector's handbook and associated software requirements for implementing the sample size methodologies described in STR-381 (Statistical Methods for Verification Sampling Plans) for the purpose of verification activities.	Delayed; work continues	Prototype sample size calculation software, based on STR-381 methodologies, has been developed. However, due to resource constraints, practical implementation procedures are still to be developed.

Expected Outcome #4 from the 2018–2019 Biennium

Improved and harmonized random inspection schemes (including short notice random inspections (SNRIs)) and methodologies developed to evaluate their effectiveness.

Supporting R&D Needs: V.5.R1 and V.5.R3

Key Outputs	Status	Comments
A set of standard random inspection schemes developed and documented, including standard evaluation methodologies as a basis for a more harmonized approach of implementing and evaluating such schemes in verification activities in continuation of a collaboration with SGCP (See also SGCP-003).	Delayed; work in progress	A randomized inspection scheme, to address quantifiable misuse scenarios and associated prototype software to calculate frequencies and achieved detection probabilities of the scheme, was developed. Due to resource constraints, harmonization work on other random inspection schemes has been limited but will continue.

Expected Outcome #5 from the 2018–2019 Biennium

Standardized methodologies for calculating detection probabilities achieved through verification activities on facility and State levels with the aim of evaluating the effectiveness of quantitative verification activities specified in State Level Approaches.

Supporting R&D Need: V.5.R1

Key Outputs	Status	Comments
Developed and documented methodologies for determining detection probabilities achieved in the implementation of verification activities specified in State Level Approaches.	Delayed; work in progress	Substantial progress on developing a methodology to expand the determination of detection probabilities from stratum to facility level has been achieved, but further (ongoing) work is needed to integrate the work with the implementation and evaluation needs of State Level Approaches.

Expected Outcome #6 from the 2018–2019 Biennium

Methodologies reviewed, requirements documented and developed for a harmonized NRTA system for future implementation in, inter alia, the Rokkasho Reprocessing Plant (RRP) and J-MOX facilities.

Supporting R&D Need: V.5.R3

Key Outputs	Status	Comments
Requirements document specifying the methodologies and data requirements for a harmonized NRTA system.	Delayed; work in progress	MSSP tasks are ongoing under FRA D 2288; JPN D 2351; ROK D 2443; UK D 2308 and USA D 2462 (NRTA system documentation and requirements gathering) for NRTA system documentation and requirements gathering. The production of NRTA documentation and requirements specifications is foreseen in 2020–2021.

Expected Outcome #7 from the 2018–2019 Biennium

Enhanced data visualization software for nuclear material flow analysis and additional capabilities of the software to represent acquisition path analysis results, verification requirements and achieved verification results, using structured nuclear material accountancy and verification data (in collaboration with SGIS-003).

Supporting R&D Need: V.4.R1

Key Outputs	Status	Comments
Data visualization software available for use by responsible operations divisions in ISE and addition of further enhancements.	Delayed; nearing completion	The Sankey diagram software for visualizing nuclear material flows across a State (SNAKEY) has been integrated into STEPS. After migration of STEPS into the Safeguards' Integrated Safeguards Environment (ISE) (foreseen in 2020), development of appropriate access management for Operations divisions to SNAKEY is planned.

Expected Outcome #8 from the 2018–2019 Biennium

Developed Bayesian approaches making use of historical verification data in the evaluation of safeguards information.

Supporting R&D Need: V.5.R1

Key Outputs	Status	Comments
Technical guidance document, based on the continuation of the methodological work begun on Approximate Bayesian Computation for UQ.	Key output achieved; work continues	A technical document has been drafted and is awaiting peer review.

Expected Outcome #9 from the 2018–2019 Biennium

Investigated accountancy and measurement requirements and gathered experience with factors affecting material balance evaluation at pyro-processing facilities (see also SGCP-003).

Supporting R&D Need: V.5.R3

Key Outputs	Status	Comments
Model material balance approach for a pyro-processing facility using results from the USA/ROK Joint Fuel Cycle Study.	Delayed; work in progress	Access to essential information relevant to the material balance approach (proposed accountancy structure, sampling points, etc.) was delayed, but is now available from the USA/ROK Joint Fuel Cycle Study.

4. Expected outcomes, key outputs and tasks for the 2020–2021 biennium

In order to achieve overall objectives and meet R&D needs, tasks must be initiated, continued and/or finalized during the 2020–2021 biennium. The following expected outcomes serve as an outline for the next 2 years.

Expected outcome #1

Standardized methodologies in support of State Level Approaches for calculating detection probabilities achieved through verification activities at facility and State levels, with the aim of supporting the determination of frequencies and intensities of quantitative verification activities and of evaluating the effectiveness thereof.

Supporting R&D Need: V.5.R1

Key Outputs	Expected Completion Date
Finalized development and technical documentation on methodology to calculate detection probability achieved through verification measurements at facility level.	December 2020
Development and technical documentation on expanding detection probabilities from facility to State level.	December 2021
Technical documentation on randomized inspection schemes to address quantifiable misuse scenarios and associated prototype software to calculate frequencies and achieved detection probabilities.	December 2020

Plans for accomplishing the expected outcome

Following the review and update of State Level Approaches (SLAs), methodologies for determining achieved detection probabilities for the verification activities specified in the SLAs will be developed. This will be achieved through MSSP tasks GER D 1925 (Optimization Approaches to Inspection/Verification Design), USA D 2427 (Expert - Statistical and Probabilistic Methodologies) and USA D 2275 (Junior Professional Officer - Associate Statistical Data Evaluation Officer) in collaboration with in-house development work and project SGIS-003: Safeguards Information Systems and System Usability.

Expected outcome #2

Improved and harmonized random inspection schemes (including short notice random inspections (SNRIs)) and methodologies developed to evaluate their effectiveness.

Supporting R&D Needs: V.5.R1 and V.5.R3

Key Outputs

Expected Completion Date

Development and documentation of a set of standard random inspection schemes, including standard evaluation methodologies, as a basis for a more harmonized approach to implementing and evaluating such schemes in verification activities.

December 2021

Plans for accomplishing the expected outcome

At present, a range of random inspection schemes are implemented in State Level Approaches. An optimized and harmonized framework of requirements and evaluation methodologies for these schemes will enable a uniform standard for such inspections to be developed. The expected outcome will be achieved through MSSP task GER D 1925 (Optimization Approaches to Inspection/Verification Design) and in-house development work in collaboration with SGCP.

Expected outcome #3

Further developed sampling methodologies described in STR-381 and practical implementation procedures for these methodologies.

Supporting R&D Need: V.5.R1

Key Outputs

Expected Completion Date

Produce prototype software implementing basic safeguards sampling procedures described in STR-381.

June 2020

Produce documentation of practical implementation procedures, for inclusion in the Inspector Handbook.

December 2020

Plans for accomplishing the expected outcome

Sampling methodologies have been prepared under MSSP task GER A 1937 (Expert - Safeguards Statistical Methodologies) and described in STR-381, *Statistical Methods for Verification Sampling Plans*. These methodologies now need to be further enhanced and to be translated into user-friendly procedures and software to be used during infield verification activities. This will be achieved through MSSP tasks GER D 1925 (Optimization Approaches to Inspection/Verification Design), USA D 2275 (Junior Professional Officer - Associate Statistical Data Evaluation Officer) and through in-house development work within SGIM, Operations divisions, and project SGIS-003: Safeguards Information Systems and System Usability.

Expected outcome #4

Reviewed, updated and consolidated algorithms for the determination of measurement error uncertainties from operator-inspector paired-data, 3-laboratory data and calibration data.

Supporting R&D Need: V.5.R3 and T.3.R2

Key Outputs

Expected Completion Date

Publication of peer-reviewed STR on Uncertainty Quantification.

December 2021

Documentation of UQ algorithms employed for Verification Measurement Performance Evaluation in STEPS.

December 2020

Plans for accomplishing the expected outcome

An accurate determination of the uncertainty in analytical measurements and non-destructive assays is important both for the operator/laboratory's measurement system and for the safeguards statistician/analyst. The expected outcome will enhance SGIM's ability to inform sampling plans, assess the significance of measurement results and material balance statistics and their implication for safeguards. This development activity will mainly be achieved through MSSP task USA D 2275 (Junior Professional Officer - Associate Statistical Data Evaluation Officer) with additional in-house development work.

Expected outcome #5

Reviewed, updated and consolidated methodologies applied to the evaluation of material unaccounted for (MUF), D, IMUF and SRD in the context of material balance evaluation.

Supporting R&D Need: V.5.R3 and T.3.R2

Key Outputs

Expected Completion Date

Technical documentation of statistical algorithms implemented in STEPS MBE module for statistical evaluations of MUF, D, IMUF and SRD.

December 2020

Plans for accomplishing the expected outcome

The methodologies and statistical tests associated with evaluating material balance and determining achieved detection probabilities are being reviewed and updated. They will then be documented and implemented within the re-engineered STEPS statistical analysis software, which is nearing completion. The expected outcome will be achieved through in-house development work, with support from MSSP task USA D 2275 (Junior Professional Officer - Associate Statistical Data Evaluation Officer).

Expected outcome #6

Methodologies reviewed, requirements documented and developed for a harmonized NRTA system for future implementation in, inter alia, the Rokkasho Reprocessing Plant (RRP) and J-MOX facilities.

Supporting R&D Need: V.5.R3

Key Outputs

Expected Completion Date

Produce comprehensive NRTA methodology documentation in the form of a STR.

December 2020

Produce requirements documentation for harmonized NRTA software system, for use as a standardized platform for NRTA evaluation systems at RRP and JMOX.

December 2021

Plans for accomplishing the expected outcome

In light of the approaching start-up of major plutonium bulk-handling facilities (RRP and JMOX), an updated NRTA system for these facilities needs to be developed with increasing urgency. Comprehensive documentation on the requirements, methodologies and needed data sources—for subsequent development of a standard NRTA software—is required. This will be achieved through MSSP tasks UK D 2308, FRA D 2288, JPN D 2351, ROK D 2443 and USA D 2462 (NRTA system documentation and requirements gathering).

A new MSSP task proposal, to implement the documented NRTA requirements, may be issued after completion of the current MSSP tasks.

Expected outcome #7

Enhanced data visualization software for nuclear material flow analysis and additional capabilities of the software to represent acquisition path analysis results, verification requirements and achieved verification results, using structured nuclear material accountancy and verification data (in collaboration with SGIS-003).

Supporting R&D Need: V.4.R1

Key Outputs

Expected Completion Date

Migration of SNAKEY nuclear material flow visualization software into ISE (as a component of STEPS) and implementation of access management system to SNAKEY to allow appropriate operations division access.

December 2020

Implement enhancements to include verification requirements and achieved verification results in nuclear material data visualization.

December 2021

Plans for accomplishing the expected outcome

The expected outcome will be achieved primarily through in-house development work (in collaboration with project SGIS-003: Safeguards Information Systems and System Usability).

However, a new MSSP task proposal may be transmitted to MSSPs. This would seek support for continuing development work on the visualization tool, to add further functionality—such as to incorporate verification requirements, achieved verification results and acquisition path analysis results—in the visualizations.

Expected outcome #8

Developed Bayesian approaches making use of historical verification data in the evaluation of safeguards information.

Supporting R&D Need: V.5.R1

Key Outputs

Expected Completion Date

Issuance of peer-reviewed technical documentation on Approximate Bayesian Computation for UQ. December 2020

Incorporation of appropriate methodology from technical documentation into statistical evaluation software for UQ. December 2021

Plans for accomplishing the expected outcome

A wealth of historical verification data is available to the Agency, representing an untapped resource that may assist in evaluating current safeguards information. Applying Bayesian approaches to this data may improve confidence in safeguards estimates. The expected outcome will be achieved through MSSP task USA D 2275 (Junior Professional Officer - Associate Statistical Data Evaluation Officer) and in collaboration with project SGIS-003: Safeguards Information Systems and System Usability.

Expected outcome #9

Investigate accountancy and measurement requirements and gather experience with factors affecting material balance evaluation at pyro-processing facilities (see also SGCP-003).

Supporting R&D Need: V.5.R3

Key Outputs

Expected Completion Date

Model material balance approach for a pyro-processing facility using results from the USA/ROK Joint Fuel Cycle Study. December 2020

Plans for accomplishing the expected outcome

The expected outcome will be achieved through in-house work within SGIM, in conjunction with SGCP. The IAEA, as a member of the trilateral safeguards and security working group (SSWG) under the USA/ROK Joint Fuel Cycle Study (JFCS), will use results from this study as a basis for developing a model material balance approach for pyro-processing facilities.

5. Attachments

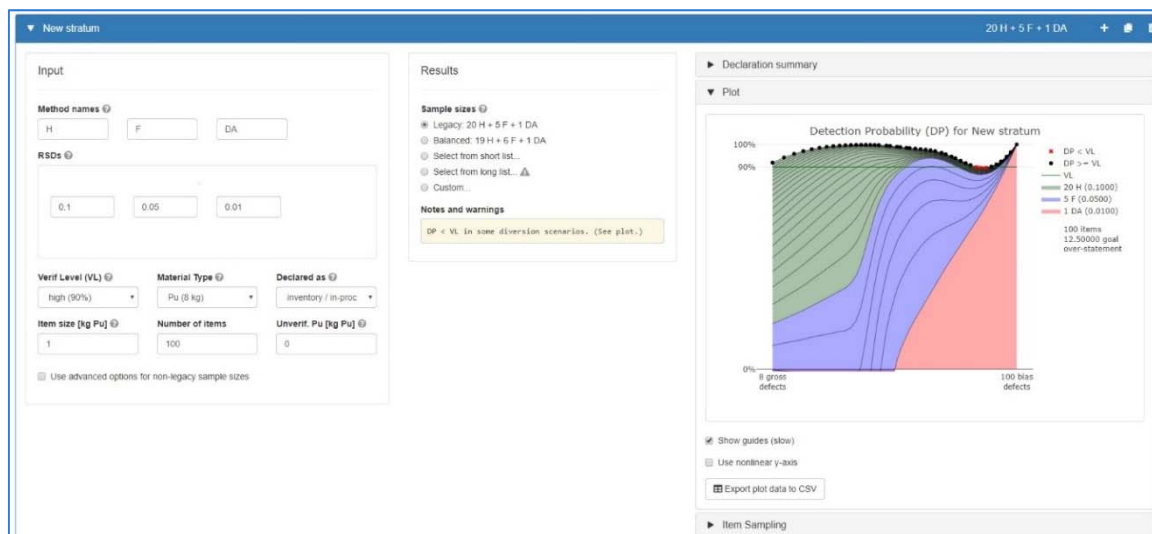

Figure 34: Nested Sample Size calculation

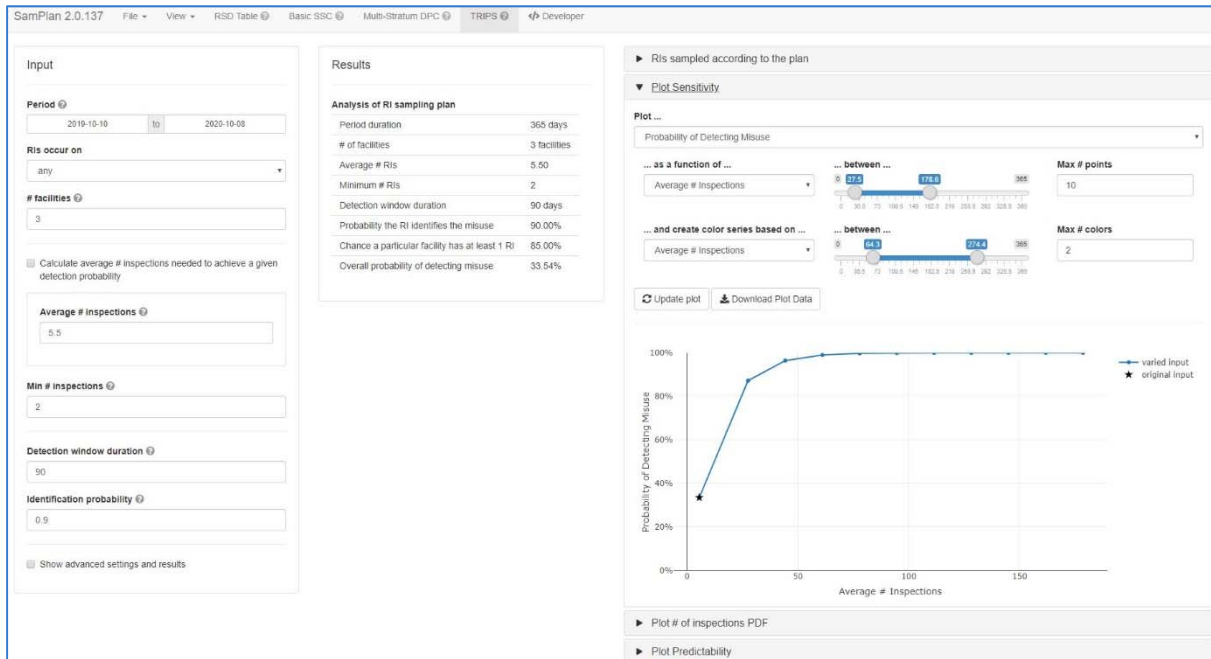

Figure 35: Random Inspection Calculation Tool

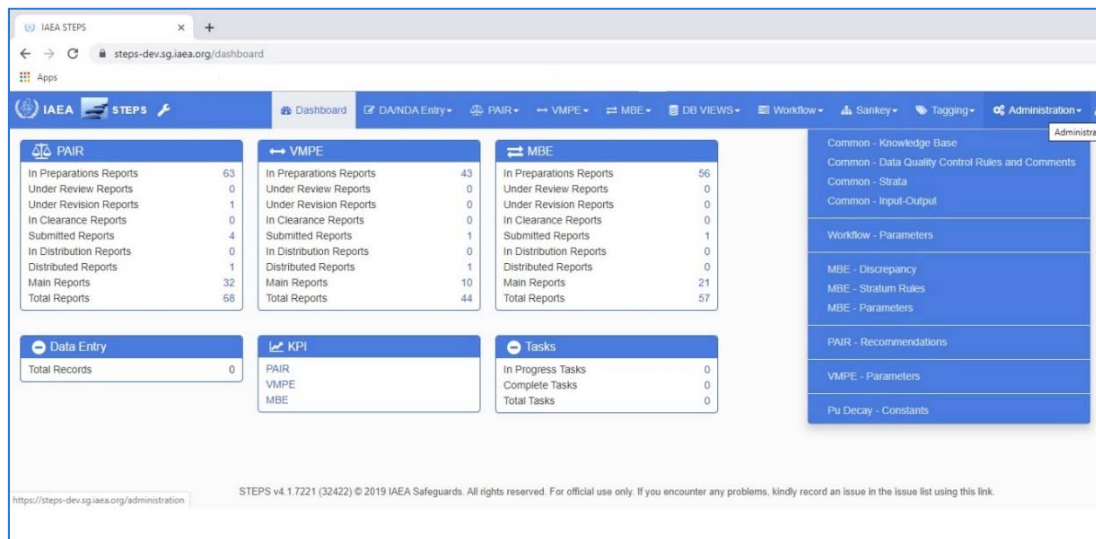

Figure 36: STEPS (Statistical Evaluation Platform for Safeguards) dashboard

SGIM-009: State-Declared Information Management

Project Manager: Snezana KONECNI

1. Overview

This chapter describes the plans for developing and implementing the process and methodologies to collect, analyse and manage State-declared information for the 2020–2021 biennium.

Project objective

The overall objective is to enhance the IAEA’s ability to collect, manage, analyse and utilize State-declared information in support of the IAEA’s verification mission, in particular with respect to the State evaluation process and support of infield verification activities.

Foreseen challenges

The greatest challenge facing the project in the coming years is ensuring a sustainable level of IT resources, to enhance the tools required to process and store State declarations. SGIM has identified many opportunities to enhance the existing suite of IAEA software tools for the processing of State declarations. Improvements to the Safeguards Master Data (SGMD) and State Supplied Data Handling (SSDH) as well as the externally facing State Declarations Portal (SDP) are foreseen to increase the effectiveness and efficiency of the Department. To realize the benefits of such enhancements, sufficient resources would need to be committed for the development teams.

Top project priorities in 2020–2021

- Update and deploy tools and methodologies for States to collect, store and submit State-declared information.
- Enhance the SDP as a tool for information exchange between States and the IAEA.
- Enhance SSDH quality checks and produce new types of reports, to support the new State Evaluation Report (SER) template.
- Develop training material and remote delivery methods, to support States or Regional Authorities (SRA) training with reduced costs and increased accessibility.

2. Strategy framework linkages

IAEA’s Programme and Budget project linkage

The plan and MSSP tasks detailed in this chapter are followed-up and/or coordinated by Agency staff and are aligned with the objectives of the Agency’s project #4.1.5.001 Declared information analysis in the *Agency’s Programme and Budget 2020–2021*.

Safeguards Research & Development Plan linkage

Priority Objective		R&D Needs	
S.2	Resolve priority areas of difficulty in SG implementation	S.2.R1	Develop training material and remote delivery methods to support SRA training with reduced costs and increased accessibility.
T.3	Support all SG processes through IT	T.3.R1	Further develop the State Declarations Portal as a tool that optimizes the quality and usability of State-declared information and enhances the State-Secretariat communication on State declarations.
		T.3.R5	Develop updated software tools for use by SRAs in creating and submitting accountancy reports and additional protocol declarations.
T.5	Identify and exploit innovations	T.5.R5	Develop training tools using technologies such as virtual reality, immersive learning systems and web-based training.
V.1	Strengthen information collection and analysis	V.1.R1	Enhance the set of expert tools necessary to process the variety of SG-relevant information and implement them, with emphasis on timely responses and cost-effectiveness.

Collaborating D&IS projects

- SGIM-002: Satellite Imagery Analysis
- SGIS-003: Safeguards Information Systems and System Usability
- SGIS-002: Information Security and Infrastructure

3. Progress on expected outcomes, key outputs and tasks from the previous biennium

Expected Outcome #1 from the 2018–2019 Biennium		
Workflow implemented between exemptions and terminations of nuclear material with the nuclear material accounting database to allow automatic checking of State reporting.		
Supporting R&D Need: V.1.R1		
Key Outputs	Status	Comments
Deployed quality control tool linking the decision-making process to the processing and evaluation of related inventory change reports	Delayed; work in progress	Resource constraints limited progress in the 2018–2019 biennium.
Expected Outcome #2 from the 2018–2019 Biennium		
Developed and updated software tools for use by SRAs in creating and submitting accountancy reports and additional protocol declarations with digital site maps attached, supporting the further integration of State declared information with other relevant information.		
Supporting R&D Need: T.3.R5		
Key Outputs	Status	Comments
Developed software, "Reports Creation Tool" (RCT), for use by SRAs in creating and submitting accountancy reports	Delayed; work in progress	The IAEA is evaluating commercial-off-the-shelf software.
Updated software "Quality Control Verification Software" (QCVS) for nuclear material accountancy reports	On hold	Euratom offered software similar to that used in its own Nuclear Material Accountancy System (ENMAS), which performs an accounting of nuclear materials, as an alternative to an upgraded QCVS. The project is on hold until the IAEA decides whether to accept the ENMAS-based software or incorporate QCVS functionality within SDP.
"Protocol Reporter 3" (PR3), software to be widely deployed to States	Delayed; work in progress	Functionalities are being developed currently to help Member States prepare AP declarations. The new version of PR3 will be ready for rollout in the second half of 2020. In PR3, digital declaration site maps (DDSM) can be added as attachments to the 2.a.(iii) declarations. A continuing need is to further evaluate and optimize States' processes of submitting DDSMs."
Expected Outcome #3 from the 2018–2019 Biennium		
State Declarations Portal largely deployed as a secure and authenticated communications system between the IAEA and SRAs.		
Supporting R&D Need: T.3.R1		
Key Outputs	Status	Comments
State Declarations Portal deployed to a maximum number of SRAs	Key output achieved; work continues	Currently used by 35 Member States (plus Euratom); deployment to additional States is in progress.

Expected Outcome #4 from the 2018–2019 Biennium

Developed training material and remote delivery methods to support SRA training with reduced costs and increased accessibility (in collaboration with SGCP-102).

Supporting R&D Needs: S.2.R1 and T.5.R5

Key Outputs

Status

Comments

E-learning modules (maximum of 20 envisaged) for training SRAs on State declaration provision

Delayed; work in progress

An e-Learning Cost Free Expert commenced work in May 2019.

4. Expected outcomes, key outputs and tasks for the 2020–2021 biennium

In order to achieve overall objectives and meet R&D needs, tasks must be initiated, continued and/or finalized during the 2020–2021 biennium. The following expected outcomes serve as an outline for the next 2 years.

Expected outcome #1

More efficient information exchange, saving time and effort through State Declarations Portal enhancements.

Supporting R&D Need: T.3.R1

Key Outputs

Expected Completion Date

NMA Reports may be validated by the Member State users so that corrective action can be taken. Validation will include the full Quality Control (QC) against historical data. Validation results, as reports, will be returned to the Member State.

December 2021

A test country mock-up exists for training and demonstration purposes.

December 2021

Improved or new internal workflows, to increase efficiency of information flows between SGIM/ISD and Operations divisions.

December 2021

The graphical user interface (GUI) is translated into five additional languages (Chinese, French, Russian, Spanish and Arabic).

December 2021

Training materials are translated into five additional languages (Chinese, French, Russian, Spanish and Arabic).

December 2021

Promotional material—in English, Chinese, French, Russian, Spanish and Arabic—is available to communicate system advantages and address user concerns regarding transmission security and/or infrastructure constraints within a Member State's decision-making authorities. Possible translations into other languages, for Member States whose adoption of the SDP would generate a high added value.

December 2021

Plans for accomplishing the expected outcome

The SDP is deployed as a secure and authenticated communications system between the IAEA and SRAs. The intention is that the SDP will evolve into a submission and validation portal where SRAs can check the quality of their declarations prior to official submission. The SDP will also allow other types of submission like DIQs, mailbox declarations, official State holidays and facility closures and any other State and safeguards-relevant information to be communicated to the Agency.

The IAEA will continue to leverage the support of MSSPs for assistance in:

- Creating e-learning modules under MSSP tasks ARG D 2283, CAN D 2240, CPR D 2441, FIN D 2330, ROK D 2242, RSA D 2251 and UK D 2352 (Creation of e-learning modules, supporting the preparation of State declared information)
- Developing and promoting the SDP under MSSP task USA F 2480 (State Declarations Portal Development and Promotion)
- Managing client management, communication, token management, client support, starter kits and training under MSSP task USA D 2476 (Junior Professional Officer - Associate State Declarations Portal Officer)

The IAEA will also seek additional resources, in collaboration with project SGIS-003: Safeguards Information Systems and System Usability, in order to integrate SSDH and SDP applications functionalities.

Expected outcome #2	
Reduced cost of, and improved access to, e-learning lessons to support SRA training (in collaboration with SGCP-102).	
Supporting R&D Needs: S.2.R1 and T.5.R5	
Key Outputs	Expected Completion Date
A new web portal, hosted by the IAEA's learning management system, is established.	December 2020
Ten 2- to 5-minute-long State declaration process e-learning modules that allow SRAs to collect and recall course material more efficiently and effectively.	December 2020

Plans for accomplishing the expected outcome

In order to support SRA training on State declaration processes at reduced cost and with increased accessibility, the possibilities for effectively delivering training by remote means will be pursued. MSSP support will be important for the development of e-learning modules in the State declaration process and for the development of remote delivery methods. Through seven active MSSP tasks—ARG D 2283, CAN D 2240, CPR D 2441, FIN D 2330, ROK D 2242, RSA D 2251 and UK D 2352 (Creation of e-learning modules, supporting the preparation of State declared information)—MSSPs support the creation of e-learning modules for the preparation of State-declared information. Funds were given by MSSPs to cover the creation of some of the e-learning modules. MSSP task USA B 2385 (Expert - E-Learning for Safeguards Reporting) is engaged in developing the material for the e-learning modules. This CFE will create story boards that will be developed into e-learning modules that are funded the UK Support Programme and will also oversee their testing and deployment. The other e-learning MSSPs tasks offered either help with testing the e-modules or translating them in other UN official languages. These NMA reporting modules will supplement international and national SSAC courses. E-learning modules will not replace the SSAC courses.

Furthermore, the IAEA proposes to distribute updated software products to Member States and has developed new means of communication with SRAs via the SDP. To facilitate these activities, the development of appropriate training materials is urgently required. The development of these materials will be covered under MSSP task USA F 2480 (State Declarations Portal Development and Promotion).

Expected outcome #3	
More efficient creation of accountancy reports, additional protocol (AP) declarations and State-declared information, integrated with other safeguards-relevant information through software tools used by SRAs.	
Supporting R&D Need: T.3.R5	
Key Outputs	Expected Completion Date
A developed software, "Reports Creation Tool" (RCT), for use by SRAs in creating and submitting accountancy reports.	December 2021
Stand-alone software "Quality Control Verification Software" (QCVS) for validating nuclear material accountancy reports will be maintained.	December 2021
Updated "Protocol Reporter 3" (PR3) software for users is widely deployed to States.	December 2021

Plans for accomplishing the expected outcome

Ongoing activity under this objective focuses on the upgrade of software tools for preparing AP declarations and nuclear material accounting reports in collaboration with project SGIS-003: Safeguards Information Systems and System Usability,

QCVS is used by many states to support the syntactically correct creation of computer-readable nuclear material accountancy (NMA) reports. The software will be maintained to run on the latest

version of Microsoft Windows. If the requirement to support the Code 10 XML format is raised, then additional resources will be required. In this case, a new MSSP task proposal may be transmitted to MSSPs to include the functionality in the existing tool that is currently Euratom by SGIS.

The new version of PR3 will offer functionalities also for Euratom countries. Euratom has not yet been involved in the rollout of the software due to their special reporting obligations. Within their MSSPs, Finland and Germany have provided in recent years requirements of Euratom States for the PR3. However, additional support is required for testing the new version by EURAT Euratom OM States. Finland, as a non Side-Letter State and Germany, as a Side-Letter State, would be best qualified for testing the new PR3 in 2020. The IAEA plans to organize a PR3 users meeting to collect input from PR3 users in 2020. This meeting would provide feedback on software usability and possibly collect new requirements as needed.

After testing the new version, the software and the user manual need to be translated into other official UN languages.

The development of a "Reports Creation Tool (RCT)" is needed to modernize the process to create reports in those States that do not have the IT capacity to provide nuclear material accountability reports in a computer readable format. There are some NMA related software tools available on the market for states that do not have this report capability. Providing the States with an existing tool will require funding from MSSPs as the tool will need to be modified for particular State. All states have different regulations and needs for keeping their NMA reporting internally. Providing NMA reports as per SG obligations and SG agreements to the IAEA will need to be implement in the chosen reporting tool. This study was initiated in 2017, and evaluation of existing tools is in progress under a MSSP task proposal to the United States Support Programme.

Expected outcome #4

A system to enable the processing of Requests for Exemption, Terminations and Re-applications. The system will allow checking between State reports and records of exemptions and terminations of nuclear material with the nuclear material accounting database.

Supporting R&D Need: V.1.R1

Key Outputs

Expected Completion Date

An implemented workflow for Exemption, Termination and Re-application requests of nuclear material. This will integrate with the nuclear material accounting system, to enable checking of State reporting.

December 2021

Deployed quality control tool linking the decision-making process to the processing and evaluation of related inventory change reports.

December 2021

Plans for accomplishing the expected outcome

The IAEA will finalize the development and deployment of a quality control tool that links the items of the decision-making process (State request, request evaluation, approval/denial of request) to the processing and evaluation of related inventory change reports. This work is expected to be pursued using extrabudgetary support, in collaboration with project SGIS-003: Safeguards Information Systems and System Usability, within the SDP project.

MSSP support is required, to procure business analysts and developers, to cover the development of new functionalities in the existing SSDH-C application to be made available through the SDP.

Expected outcome #5

Upgraded Safeguards Master Data (SGMD) application.

Supporting R&D Need: V.1.R1

Key Outputs

Expected Completion Date

SRA address integration in SGMD.

December 2021

Deployment of related SGMD reports.

December 2021

Plans for accomplishing the expected outcome

Safeguards Master Database (SGMD) was one of the first applications completed under the MOSAIC project in collaboration with project SGIS-003: Safeguards Information Systems and System Usability. SGMD is used to manage all State-relevant information about SG agreements, dates of agreements entering in force, information about the SRA and point of contacts, list of facilities and material balance areas. SGMD is an internal SG application with limited development resources. There is a need to improve the user experience and the SGMD services provided to other IT applications. The IAEA requests MSSP support for the continued maintenance and enhancement of the SGMD application in alignment with the project roadmap.

5. Attachments

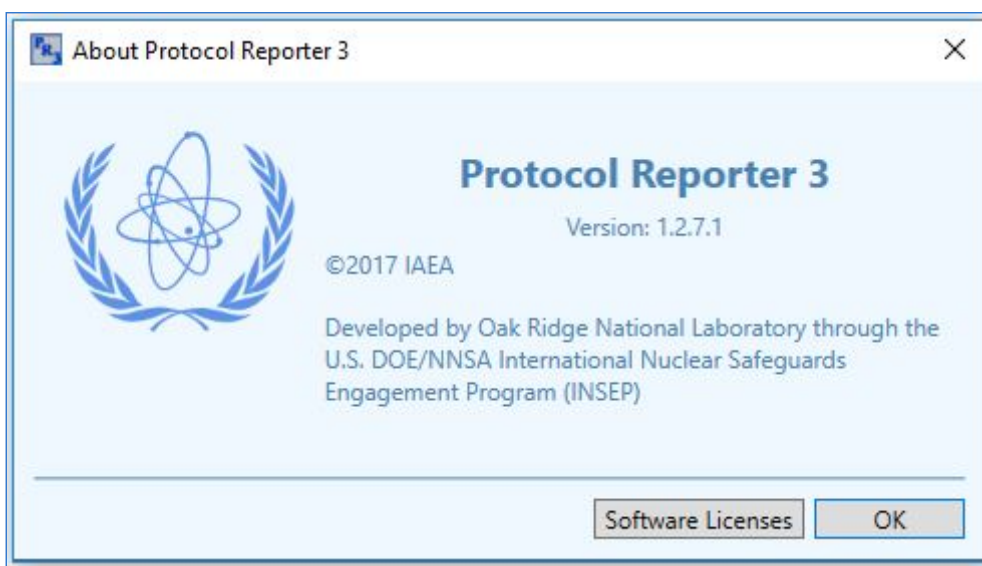

Figure 38

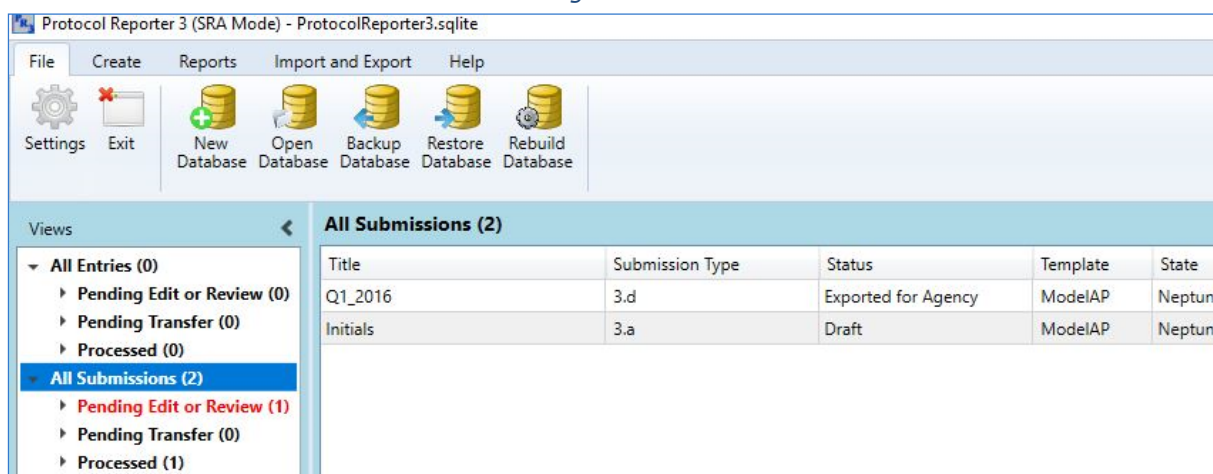

Figure 38 & 39: The Protocol Reporter 3 (PR3) software, which is intended to assist States in the creation, management and submission of declarations pursuant to their obligations under the Additional Protocol, has been developed with MSSP support.

SGIS-002: Information Security and Infrastructure

Project Manager: Scott PARTEE

1. Overview

This chapter describes the plans for developing and implementing Information Security and Infrastructure for the 2020–2021 biennium.

Project objective

The overall objective is to make use of processes, people, technology and tools to ensure the confidentiality, integrity and availability of the information entrusted to the Department and to support the comprehensive management of its security.

Foreseen challenges

Information security remains a critical focus for the Department, and a lack of investment in this area could seriously undermine protection of the Department's assets. As the number of mandated missions for safeguards grows, so too do the Department's requirements for secure physical space for IT infrastructure, securing a growing amount of sensitive information and promoting and maintaining an effective security culture. This growth, and the current political and high-threat operating environment, requires support additional to the major capital investment in IT infrastructure under the Modernization of Safeguards Information Technology (MOSAIC) project.

Without extrabudgetary support, the ability to strengthen information security operations through implementation and monitoring of critical security control, evolve protection to meet ever-changing threats and guarantee the confidentiality, integrity and availability of safeguards information would be seriously compromised.

Business continuity and disaster recovery (BC/DR) capabilities need to be maintained at a level commensurate with continued developments elsewhere within the Department. Extrabudgetary support will enable such capabilities to be developed on a timeline that would mitigate the risks associated with recovery from a disaster in the near future.

Top project priorities in 2020–2021

- Continuously improve information security by implementing and monitoring critical security controls, testing security systems and installations and addressing the test results and strengthening security operations to prevent, detect and respond to security incidents.
- Ensure authorized user access and prevent unauthorized access to systems and services at all times, across all applications and networks.
- Support the proper and effective use of cryptography to protect the confidentiality, integrity and authenticity of information and ensure that information transferred internally and with external entities is protected from unauthorized disclosure, alteration or destruction.
- Develop secure mobile technology and communications capabilities.
- Prevent unauthorized physical access, damage and interference to the organization's information processing facilities.
- Enhance the Department's ability to recover from an information technology (IT) failure.
- Expand the awareness and capabilities of departmental staff members to maintain effective information security.

2. Strategy framework linkages

IAEA's Programme and Budget project linkage

The plan and MSSP tasks detailed in this chapter are followed-up and/or coordinated by Agency staff and are aligned with the objectives of the Agency's project #4.1.9.002 ICT infrastructure and support in the *Agency's Programme and Budget 2020–2021*.

Safeguards Research & Development Plan linkages

Priority Objective		R&D Needs	
P.1	Ensure information security	P.1.R1	Improve the capability to quickly identify and react to security events within the Department's information systems.
		P.1.R2	Improve Information Security capabilities in areas of risk: management, auditing and reporting; vulnerability management; threat intelligence; and improve processes, procedures and standards.
P.2	Increase resilience and prepare for disaster recovery	P.2.R1	Address requirements (processes and technology) for carrying out mission-critical functions (needed for continued delivery of SG conclusions) in case of disasters (e.g., disruptive, massive cyber attack or physical loss of critical infrastructure).
W.1	Reform human resource management	W.1.R1	Develop and maintain, through training, new expertise required by the Department, where needed, with the help of Member States.

Collaborating D&IS projects

- SGIS-003: Safeguards Information Systems and System Usability
- SGTS-014: Remote Monitoring and Data Processing Systems

3. Progress on expected outcomes, key outputs and tasks from the previous biennium

Expected Outcome #1 from the 2018–2019 Biennium		
Improved and automated detection of events, system anomalies and activities in the Department's information systems – particularly in the case of the Integrated Safeguards Environment (ISE).		
Supporting R&D Need: P.1.R1		
Key Outputs	Status	Comments
Additional automated platform alerting modules and correlation rules for the Department's Security Incident and Event Management Platform	Key output achieved; work continues	The new Security Incident and Event Management Platform was delivered and will be continuously improved.
Documented definition and implementation of security analytics	Key output achieved; work continues	Initial security Key Performance Indicators (KPI) are developed and tied to the strategic plan and programmatic objectives.

Expected Outcome #2 from the 2018–2019 Biennium		
Improved Department's security configurations and system designs through periodic independent assessments of specific solutions for risk and vulnerabilities and comprehensive or targeted penetration tests.		
Supporting R&D Need: P.1.R2		
Key Outputs	Status	Comments
Reports on vulnerability assessments and penetration tests in order to identify potential issues with system configurations, to design solutions and to verify security controls	Key output achieved; work continues	The Department conducted frequent security assessments and implemented improvements based on the findings.
Improvement guide for overall information security maturity based on risks identified in the assessment report	Key output achieved; work continues	Gap analysis was completed and used as an input to the current project plan.

Assessment report on the maturity level of the Secure Software Development Lifecycle in place within the Department

On hold

This is moved to the 2020-2021 plan.

Expected Outcome #3 from the 2018–2019 Biennium

Improved Departmental information security and IT security skills through targeted training on specific topics related to threat detection, incident response, secure software development, security designs, continuous monitoring, event management, digital forensics and security architecture.

Supporting R&D Need: W.1.R1

Key Outputs	Status	Comments
Training of departmental staff members in targeted IT security areas identified as critical needs, such as new technologies, security metrics, security incident response, digital forensics, specific security products and secure software and systems development processes.	Key output achieved; work continues	Support for training was received from MSSPs in a number of areas. Further training activities will be required, with some to be considered ongoing.

Expected Outcome #4 from the 2018–2019 Biennium

Enhanced endpoint and server security protection capabilities of the Department's IT infrastructure through the use of next generation techniques.

Supporting R&D Need: P.1.R2

Key Outputs	Status	Comments
Implementation of a next generation endpoint security solution for the clients and servers in the general purpose computing network.	Deferred	A solution based on "next generation" techniques was not adopted due to resource constraints and, at present, an unclear proof of value for solutions implemented in peer organizations and teams. Further investigations into alternative options may take place.
Implemented solution to mitigate threats from the use of web browsing on the Department's computers through the use of non-persistent, virtualized computing resources and spread this capability to additional computing environments.	Deferred	Initial assessment of implementation costs in terms of resources and the cost.
Secured, thin-client access to the Department's networking resources based on virtualized desktop computing technology.	On hold	Resource unavailability.

Expected Outcome #5 from the 2018–2019 Biennium

Deployed secure and authenticated communications between inspectors in the field and IAEA headquarters/regional offices.

Supporting Priority Objective: P.1

Key Outputs	Status	Comments
Implementation of a secure messaging solution for a mobile workforce that supports 'chat' and voice communications and applies confidentiality protections to a level that meets the Department's assurance criteria	Delayed, work in progress	Significant research did not yield a viable solution that meets requirements within an acceptable budget. Research will continue and this need was included in the plan for 2020–2021 (under expected outcome 3).
Pilot, design and deployment of an end-to-end security and management solution which provides the controls and capabilities necessary to enable secure email on standard mobile devices such as iPhones. The solution will work with the Agency's Public Key Infrastructure and support hardware protection of private keys used for S/MIME secure email	Key output achieved; work continues	Pilot implementations were tested. Solution meets functional, non-functional and security requirements. Further deployment requires resources and this need was included in the plan for 2020–2021 (under expected outcome 3).

Expected Outcome #6 from the 2018–2019 Biennium

Enhanced ability of the Department to recover from an IT failure.

Supporting R&D Need: P.2.R1

Key Outputs	Status	Comments
Fully implemented Phase I of SGIS Disaster Recovery Project, including plan to respond to a disaster scenario and upgraded IT infrastructure	Key output achieved; work continues	Redundant core IT infrastructure installed, configured and preliminary testing complete to provide redundancy. Security Event Management systems, internet connectivity and formal testing procedures are still outstanding.
Advanced Phase II of SGIS Disaster Recovery Project, including plan to respond to an alternative disaster scenario, upgraded dual purpose IT infrastructure in Seibersdorf and procedure documentation	Delayed; work in progress	Additional internal resources engaged to maintain progress. However, this work will be delayed until fully resourced.

Expected Outcome #7 from the 2018–2019 Biennium

Support to the Department’s access, authorisation and information classification initiatives in order to ensure information is available to those who need it while protecting the confidentiality and integrity of that data.

Supporting R&D Need: P.1.R2

Key Outputs	Status	Comments
Expert reports on authorization management, information classification and information access management areas, as required	Key output achieved; work continues	N/A

4. Expected outcomes, key outputs and tasks for 2020–2021 biennium

In order to achieve overall objectives and meet R&D needs, tasks must be initiated, continued and/or finalized during the 2020–2021 biennium. The following expected outcomes serve as an outline for the next 2 years.

Expected outcome #1

Sufficient security knowledge is reflected in policies, procedures, governance and staff culture.
Supporting R&D Needs: W.1.R1, P.1.R1 and P.1.R.2

Key Outputs	Expected Completion Date
The Safeguards Information Security Management System’s (ISMS) policies, procedures and governance will meet the requirements of the Division of Nuclear Safety and Security (NSNS) as well as the Department’s, and are based on International Organization for Standardization (ISO) standards.	December 2020
A measurable and coordinated information security management programme is in place.	December 2020
Security awareness training and testing is in place.	December 2021
Training is available for departmental staff members in new technologies, security metrics, security incident response, digital forensics, specific security products and secure software and systems development processes.	December 2021

Plans for accomplishing the expected outcome

The Department conducted an in-house security management system gap analysis, which was then assessed by a third party. From this, a plan was created to achieve a Department-specific ISMS, based on ISO standards and with full consideration for the NSNS ISMS.

The initial set of policies, procedures, standards and guidelines was implemented by departmental staff members with Department-wide security responsibilities. This initial set is considered a solid foundation for information security management within the Department. For the 2020–2021 biennium, enhancements and further development of procedures is expected to continue, as well as additional policies to address more areas of the Department’s business.

To enact comprehensive security management in the Department, the aim is to streamline governance and consolidate the Department’s information and physical security activities. The Department needs to procure required resources to systematically address the existing and emerging risks, following International Organization for Standardization/International Electrotechnical Commission (ISO/IEC) 27001 methodology, and to support implementation of the security tasks. Member States are asked to contribute expertise, financial support and reviews of documentation towards this aim.

To achieve and maintain the level of security that is necessary, a motivated and skilled workforce is required. Member States have an important role in staff development, including sponsoring relevant training courses, associated travel and course fees for appropriate departmental staff members. Those with specific security responsibilities would benefit from access to conferences, trust groups and threat intelligence sharing communities. The Member States are often best-placed to facilitate such access, in addition to more tangible extrabudgetary support to training.

Expected outcome #2

Strengthened access control solutions.

Supporting R&D Need: P.1.R2

Key Outputs

Expected Completion Date

Enhanced and integrated Authorization Management System, including extending the centralized authorization system to unstructured data stores and resources which are currently managed through other means.	Continuous
Access control solutions are in place that eliminate the risk of unauthorized access to systems and services.	Continuous

Plans for accomplishing the expected outcome

Plans include integrating authorization management solutions with existing systems and extend authorization solutions and data to support other resources that are managed manually, such as file shares and unstructured data store solutions, in collaboration with project SGIS-003: Safeguards Information Systems and System Usability.

Member States are requested to financially support extension of the Department's Authorization Management (AM) solution, which was delivered as part of the MOSAIC project. This is a critical area of focus, to ensure uniform access and authorization management. Consistent and automated authorization management, developed by the Department, is now a mature capability. Investing in the platform and spreading its use will further enhance information security within the Department and maximize the value of the original development.

Plans are in place to further enhance the AM solution's features, to regularly review user access rights and prevent unauthorized access to systems and services. This will ensure that departmental staff members responsible for the Department's information know exactly who has access to that information and can continuously review data access assignments, to ensure that the access is based on a need-to-know principle.

Expected outcome #3

Increased trust in the Department's information and systems through enhanced cryptography and secure communication solutions.

Supporting R&D Need: P.1.R2

Key Outputs

Expected Completion Date

Developed and deployed software is authenticated and trusted. Software developed by the Department will be digitally verifiable as authentic.	May 2020
Ability to securely transfer between internal and external parties safeguards-relevant data, additional to that already accommodated within secure declarations, in accordance with agreed safeguards processes (for example, to securely share relevant information for projects, subject to statutory limitations).	September 2020
Enhanced key management standards and solutions.	May 2021
Secure email for mobile devices.	December 2020
End-to-end secured solutions for communication.	December 2021

Plans for accomplishing the expected outcome

Plans are in place to develop a complete set of extensions to the current Public Key Infrastructure (PKI) policy, to provide automation and extensive encryption and signature capabilities.

Member States with knowledge and capabilities in encryption are invited to share expertise and templates. Additionally, financial support to procure any necessary Hardware Security Modules (HSMs) or integration tools would assist early adoption of resultant technical solutions.

As part of the MOSAIC project, the Department developed the SG Security Model via a set of in-house products. The Department plans to enhance the SG Security Model to enable the security and

control of large information files to be maintained during transfer within the Department and with external entities.

MSSPs are requested to provide financial support to enable in-house developments which can be integrated with the SG Security Model products. In addition to financial support, the Department would encourage Member States to make available any relevant expertise or solution designs from capabilities resident in Member States.

The Department of Safeguards has, primarily, a mobile workforce. The Department introduced modern mobile devices in 2013 and has noted that such devices increase productivity and enable improved communication and collaboration. The challenge has been that such devices are not, at present, authorized for handling sensitive data. To gain maximum benefit from their introduction, the Department must introduce additional security controls and features to the mobile device fleet. A pilot solution has been developed for end-to-end encryption for email communications, but further support is required to roll out the solution, the tools and the techniques for managing secure mobile devices.

MSSPs are requested to contribute expertise and implementation guidance to the roll out and funding to support procurement of tools and training.

Further to the desire to increase the use of mobile technology, there is need to implement secured voice, text and telepresence-style communications in offices and on mobile devices.

The Department would benefit from expertise, implementation guidance and funding to support these developments.

Expected outcome #4	
Enhanced security controls on operational systems and solutions.	
Supporting R&D Needs: P.1.R1 and P.1.R2	
Key Outputs	Expected Completion Date
Improved secure development lifecycle for SG products.	December 2021
Improved insider and external threat detection and "threat hunting" capabilities.	December 2021
Security assessments and improved incident management solutions.	December 2021

Plans for accomplishing the expected outcome

The Department employs security tools to ensure that software products do not introduce critical security vulnerabilities into its information systems. Any vulnerabilities detected in software are managed, but introducing less vulnerabilities in the first place improves overall efficiency and reduces risk. This requires additional processes and tools in the software development process, often referred to as a secure software development lifecycle (SSDL). At present, the Department's SSDL comprises of a baselined security architecture and baseline security standards.

Support is requested from Member States, through a number of activities, to enhance the existing SSDL. These include software security assessments, expertise and resources that define and implement new tools and procedures and guidance through contact with other groups working on similar initiatives.

The Department conducted a gap assessment related to policies, procedures, standards and guidelines in the 2018–2019 biennium. Further to this, the Department conducted an assessment of the maturity levels of critical security controls for mitigating the risk of targeted cyber intrusions. With this measurement, the Department now has a valuable metric to focus on achieving a higher level of maturity on the most efficacious security controls for protecting the Departments information from cyber attacks. The Department has created a plan for achieving higher maturity levels in targeted areas, but the scope and pace of implementation are constrained by available resources.

Member States are requested to support the Department in achieving increased levels of maturity by:

- Providing additional assessments
- Contributing financially to the procurement of tools and expertise
- Facilitating engagement between Member State experts and the Department's experts and supporting the development of staff knowledge and capabilities
- Continuing to support Cost Free Experts and Junior Professional Officers, to build or enhance control areas

While targeting maturity levels and continuously improving the security controls in the Department is important, a complementary focus is equally vital: discovering and mitigating vulnerabilities that would otherwise remain undetected during Operations activities.

One method for discovering such vulnerabilities, which has proved immensely valuable for the Department, is engaging high-level security experts to test and assess the security of specific systems and the overall security controls across the Department. Member States have contributed to this effort and provided invaluable access to such experts. Continued support for security testing is requested in the form of security testing by experts from Member States and provision of financial support for procuring expertise as necessary.

Expected outcome #5	
Increased trust in the Department through enhanced physical security and environmental solutions. Supporting R&D Needs: P.1.R1 and P.1.R2	
Key Outputs	Expected Completion Date
Enhancements to the physical security system.	March 2020
Enhancements to the physical access control mechanisms.	June 2021
Development of potential next generation physical security systems.	June 2020

Plans for accomplishing the expected outcome

The Department intends to integrate its physical access control systems with the security incident and event management platform in order to better correlate and detect information security events. To complete this integration, the Department must interconnect networks, install a means of secure connection, additional card readers, add doors and upgrade cameras. Furthermore, the Department must replace and re-program card readers to ensure greater auditability of access to secure areas and mitigate existing vulnerabilities and re-program alarms and conduct re-cabling activities to provide coverage and response to alerts.

In order to assess the systems security and the future fitness for purpose, the Department plans to carry out physical intrusion testing consultancies and testing, which will help derive plans for the future of the system. Additionally, an effort is underway to investigate current open-architecture platforms that could bring a number of benefits (simplification, standardization, wider support options, more secure protocols).

Support from Member States will be required in order to achieve these outcomes, through the provision of expertise and financial contributions.

Expected outcome #6	
Increased ability to remain operational after an adverse event through BC/DR capabilities including planning, equipment, IT solutions, facilities and regular exercises. Supporting R&D Need: P.2.R1	
Key Outputs	Expected Completion Date
Plans, policies and procedures for continuity and recovery events.	December 2020
Arrangements for ensuring availability of critical equipment in the event of disruption, including detailed business continuity plans.	December 2020
Identification and availability of alternate facilities.	May 2021
Enhanced IT Disaster Recovery (DR) capabilities.	December 2021
Exercised and maintained BC/DR programme.	December 2021
Training for departmental staff members.	December 2021

Plans for accomplishing the expected outcome

For Disaster Recovery and Business Continuity, the Department must develop a concept of operations (CONOPS) and establish reporting requirements for senior management and function-

critical departmental staff members, including human capital considerations and logistical requirements for each Division.

To refine the plan, the Department must first revisit existing business impact analysis (BIA) findings.

The Department plans to establish redundant communication channels and develop an overall approach with separate location-specific annexes for the Vienna International Centre (VIC), laboratories in Seibersdorf and regional offices in Tokyo and Toronto.

As part of the overall plan, the Department must develop outreach material, nominate teams, identify critical departmental staff members and publish a draft BC/DR plan for review.

The Department must analyse and then plan for the availability of equipment for infield activities to continue and arrange for equipment storage and maintenance including identifying available storage space and inventory procedures.

Additionally, the Department must digitize the Office of Safeguards Analytical Services (SGAS) library of hard-copy sample analysis reports, in order that the information is available independent of the facility. This task will include:

- Scanning of documents.
- Organizing documents into a database.
- Proving the ability to retrieve documents from the SGAS Laboratory Information Management System (LIMS).

The Department must identify alternate facilities for the relocation of departmental staff members from Seibersdorf, Tokyo and Toronto; develop configuration of space at each of the alternate facilities; establish lists of vendors and develop scopes of contracts for essential on-call services at each of the alternate facilities.

The Department must conduct a feasibility study for disaster recovery solutions and facilities which meet the objectives for various recovery time and provide data protection which meet both the Department's requirements and are feasible.

As part of disaster recovery, the Department must integrate existing IT resumption Standard Operating Procedures (SOPs) in the DR plan, add any missing documentation and identify function-critical departmental staff members to carry out the plan and assign primary and alternate positions on the Safeguards Information Technology Disaster Recovery (SG IT DR) team. The SG IT DR team must develop a specific IT DR testing and maintenance plan focused on increased capabilities and complexities of scenarios.

The plan requires the Department to develop and implement a training and awareness programme. Training materials and other forms of communication (posters, website banners, etc.), as well as briefings for external stakeholders (other VBOs, other IAEA departments) on the SG BC/DR programme, will be prepared.

Finally, the plan must include the creation and implementation of an exercise programme, aimed at BC/DR teams (primary and alternates) and other departmental staff members, including a series of exercises involving different scenarios with increasing complexity.

Member States are requested to assist this task by:

- Seeking opportunities to consult and engage the Department on arrangements for alternate sites and equipment
- Validating plans and arrangements
- Providing financial support for equipment and technologies to enable the plan
- Supporting travel and training for departmental staff members involved in the implementation of the plan.

Member States are also requested to provide expertise in terms of consultants or Cost Free experts to develop and implement the plan.

SGIS-003: Safeguards Information Systems and System Usability

Project Manager: Gregg WHITAKER

1. Overview

This chapter describes the plans to continue developing, implementing and maintaining an integrated information technology (IT) system to support the safeguards implementation processes for the 2020–2021 biennium.

With the completion of the Modernization of Safeguards Information Technology (MOSAIC) project in 2018, the Department is equipped with over 20 new and refurbished integrated applications supporting departmental processes. This integration has increased consistency of data across IT applications, delivered higher quality outputs and a more productive use of staff time. SGIS has aligned core departmental processes with the management of the IT applications by domain processes - state-cooperation, verification, analysis and services. In 2020–2021, there is a need for SGIS to continue developing new applications in support of all processes as well as maintaining and improving existing applications to increase the efficiency and effectiveness of departmental business. The domain processes outlined in the 2020–2021 implementation plan allows SGIS to be agile in meeting the evolving needs of departmental staff members.

In 2018, the Office of the Information Systems (SGIS) established an IT governance (See IT Governance figure in attachments section) to ensure its IT development follows Departmental strategic priorities and business needs. This includes:

- Individual departmental staff members have assumed the roles of product owners for each IT application. These user representatives help SGIS define requirements and ensure that development occurs in line with operational needs.
- SGIS product teams⁶ and Product Owners prepare roadmaps for the Department's IT applications undergoing active development. The roadmaps, which outline the vision and main activities planned for each application, are updated on a quarterly basis in consultation with departmental staff members.
- The Safeguards IT Sub-Committee, composed of representatives from across the Department, reviews and prioritizes proposed work on existing applications and on new projects.

All departmental projects with IT support tasks will collaborate with SGIS-003 to ensure compliance with SGIS IT standards and best practices. This alignment of IT projects across the departmental facilitates the integration, security and availability of safeguards data.

In 2018–2019, MSSPs provided resources under MSSP tasks JNT D 2171 UK, 2106 USA, 2284 FIN, 2107 ROK and 2100 CAN (Developing Business Capabilities for the Modernization of Safeguards Information Technology (MOSAIC)). In 2020–21, MSSPs who accept MSSP task proposal 18/GIS-002 (Keeping Safeguards IT Updated) will provide resources for the development of new and existing Safeguards IT capabilities.

Four JPOs and CFEs are available in the 2020–2021 biennium who will help this project to achieve its expected outcomes:

- USA A 2336 (Expert - User Experience Developer)
- USA D 2448 (Expert - Information Architect)
- USA A 2262 (Junior Professional Officer - IT Systems Engineer)
- USA D 2312 (Junior Professional Officer - Support for IT Service and Process Improvements)

Project objective

The overall objective is to ensure the Department's modernized IT platform continues to enable the Department to carry out its mission in an effective, efficient and secure manner.

Foreseen challenges

An increasing workload places requirements on the Department for extensive IT support across business processes. Given limited regular budget financial and human resources, continued

⁶ A Product Team, responsible for implementing roadmaps, includes product owners, subject matter experts, product managers, business analysts, quality engineers and developers from SGIS.

extrabudgetary support is essential to maintain and further improve the current high-quality standards of IT applications.

Top project priorities in 2020–2021

- Enhance and continuously improve existing IT applications supporting the Department’s business, in particular its Services, State-cooperation, Analytical and Verification domain processes.
- Identify and develop new safeguards-relevant software capabilities in line with departmental strategic priorities that will optimize operations.
- Ensure the confidentiality, integrity and availability of safeguards information.

2. Strategy framework linkages

IAEA’s Programme and Budget project linkage

The plan and MSSP tasks detailed in this chapter are followed-up and/or coordinated by Agency staff and are aligned with the objectives of Agency’s projects #4.1.9.001 ICT Development and #4.1.9.002 ICT Infrastructure and Support in the Agency’s Programme and Budget 2020–2021.

Safeguards Research & Development Plan linkage

This D&IS project supports a broad set of the Department’s R&D Needs. This includes but is not limited to the following R&D Need:

Priority Objective	R&D Needs
T.3 Support all SG processes through IT	T.3.R1 Further develop the State Declarations Portal as a tool that optimizes the quality and usability of State-declared information and enhances the State-Secretariat communication on State declarations.
	T.3.R2 As part of the STEPS (Statistical Testing, Evaluation and Planning for SG) project, re-engineer and integrate all the legacy systems used for the statistical evaluation of State declared and verification data and the probabilistic calculations that inform verification approaches (e.g., sampling plans and random inspection schemes).
	T.3.R3 Build on the development of geographic information systems (GIS) technology to enhance geo-based information sharing and related analysis.
	T.3.R5 Develop updated software tools for use by SRAs in creating and submitting accountancy reports and additional protocol declarations.
T.4 Manage SG assets strategically	T.4.R1 Execute a long-term maintenance and replacement plan for the safeguards information technology system as a follow-up to MOSAIC.
V.1 Strengthen information collection and analysis	V.1.R1 Enhance the set of expert tools necessary to process the variety of SG-relevant information and implement them, with emphasis on timely responses and cost-effectiveness.
	V.1.R3 Further integrate safeguards information to strengthen all-source information analysis and make it more user-friendly (e.g., via the Collaborative Analysis Platform).
V.4 Enhance SG effectiveness monitoring and evaluation	V.4.R1 Identify and deploy analytical tools, including data visualization, to better measure and analyse performance and take advantage of capabilities provided by MOSAIC.
V.5 Employ fit-for-purpose and state-of-the-art methodologies	V.5.R3 Explore data analysis methods and tools to strengthen the synthesis and evaluation of information (e.g., optimal random verification schemes, nuclear material flow analysis, material balance evaluation, near real-time accountancy, and process monitoring tools).

Collaborating D&IS projects

- SGCP-004: Strategic Planning and Partnerships
- SGCP-101: Quality Management
- SGCP-102: Training
- SGIM-002: Satellite Imagery Analysis
- SGIM-003: Information Analysis
- SGIM-008: Statistical Analysis
- SGIM-009: State Declared Information Management
- SGTTS-014: Remote Data Transmission and Processing Systems
- SGVI-001: JCPOA Verification

3. Progress on expected outcomes, key outputs and tasks from the previous biennium

Expected Outcome #1 from the 2018–2019 Biennium		
<p>Enhanced integration of diverse information sources, including satellite imagery, electronic data (including images), technical and academic literature, trade data, etc., to detect inconsistencies in nuclear programmes and States' declarations.</p> <p>Supporting R&D Needs: T.3.R2, T.3.R3 and V.1.R3</p>		
Key Outputs	Status	Comments
<p>Additional legacy systems integrated for the statistical evaluation of State declared and verification data and the probabilistic calculations which inform verification approaches (for example, sampling plans and random inspection schemes) (in cooperation with SGIM-008)</p>	<p>Key output achieved; work continues</p>	<p>The project achieved the following:</p> <ul style="list-style-type: none"> • Enhanced integration of 15 systems to improve access to departmental data • Faster processing of declared information with enriched quality control functions, which decreased the time required to compile data for the State Evaluation Report (SER) and the Safeguards Implementation Report (SIR) processes. For the 2018 SIR, 66 percent of the data was directly loaded from Safeguards IT applications.
<p>Enhanced geo-reference capabilities in Safeguards applications to improve the integration of geo-tagged information for analysis activities (in cooperation with SGIM-002)</p>	<p>Key output achieved; work continues</p>	<p>Enhanced integration of systems to search and visualize maps with safeguards data to assist verification, analysis and evaluation activities.</p>

Expected Outcome #2 from the 2018–2019 Biennium

Enhanced tools and systems for 'all source analysis' to support the detection of signatures of undeclared activity and improve the analysis of nuclear fuel cycles.

Supporting R&D Needs: V.1.R1 and V.4.R1

Key Outputs	Status	Comments
Expanded Department's capability to translate languages in Safeguards IT applications (in cooperation with SGIM-003)	Key output achieved; work continues	Developed capability to generate provisional translations of declarations made in languages other than English while working in the secure Integrated Safeguards Environment (ISE).
New IT capabilities identified for the integration and visualization of safeguards data in support of the Physical Model and the acquisition/diversion path analysis for the development of State Level Approaches (in cooperation with SGIM-008)	Key output achieved; work continues	The Collaborative Analysis Platform (CAP) helped automate the collection of safeguards-relevant, open source information and categorize it in relation to the nuclear fuel cycle.

Expected Outcome #3 from the 2018–2019 Biennium

Enhanced capabilities to evaluate data analysis methods and computerized tools to aid the analysis of large amounts of all-source information in order to support the State evaluation process.

Supporting R&D Needs: V.1.R1, V.1.R3 and V.5.R3

Key Outputs	Status	Comments
Developed functionality to view all State-relevant data in the State File, including integration of documents and information residing in other systems, the organization of non-structured data, and the process to analyse and evaluate information (in cooperation with SGIM-003)	Key output achieved; work continues	The integration of the Electronic State File (eSF) application with other IT applications provided departmental staff members a 'virtual workspace' in which to work collaboratively.
Continued development of the Natural Language Processing task, moving from the development stage to the deployment stage (in collaboration with SGVI-001 and SGIM-003)	Key output achieved; work continues	With support under MSSP tasks JPN D 2211, USA D 2222, CZ D 2207, GER D 2345, ROK D 2244, CAN D 2234, FRA D 2267 and UK D 2214 (Natural Language Processing Investigative Tooling and Databases), the IAEA developed the capability to collect a large amount of unstructured information from the internet. The project has moved into an internal development and implementation phase.

Expected Outcome #4 from the 2018–2019 Biennium

Enhanced updated software tools for use by SRAs in creating and submitting accountancy reports and additional protocol declarations, supporting the further integration of State declared information within the electronic State file.

Supporting R&D Needs: T.3.R1 and T.3.R5

Key Outputs	Status	Comments
Enhanced IT capabilities identified to securely exchange electronic data for the Department and Member States	Key output achieved; work continues	Enhanced the State Declarations Portal (SDP) to automatically transfer encrypted declarations to ISE, decrypt the declarations and upload them into secure applications. This work significantly reduced the time to process State reports and declarations with the State Supplied Data Handling (SSDH) tool.

4. Expected outcomes, key outputs and tasks for the 2020–2021 biennium

In order to achieve overall objectives and meet R&D needs, tasks must be initiated, continued and/or finalized during the 2020–2021 biennium. The following expected outcomes serve as an outline for the next 2 years.

Expected outcome #1

Improved Safeguards IT Products supporting IAEA Safeguards business more effectively and efficiently.

Supporting R&D Needs: T.3.R1, T.3.R2, T.3.R3, T.3.R5, T.4.R1, V.1.R1, V.1.R3, V.4.R1 and V.5.R3

Key Outputs	Expected Completion Date
Improved Safeguards IT Products supporting analytical, services, State cooperation and verification processes to enhance the user-experience and system performance with an increased number of IT features and business capabilities.	December 2021

Plans for accomplishing the expected outcome

To achieve this expected outcome, this project plan will regularly engage departmental staff members to identify and prioritize enhancements of the existing Safeguards IT applications. The plans in the form of product roadmaps are updated and reviewed on a quarterly basis by the Safeguards IT Sub-Committee.

Applications and their intended improvements that support Safeguards *analytical* processes:

- **Safeguards Analytical Tool (SANT):** Increase the number of data sources that automatically retrieve data for the production of the Safeguards Implementation Report (SIR); provide IT support for anticipated changes to the content and structure of the SIR and develop data visualization reports on Safeguards key performance indicators using advanced information analysis capabilities.

Applications and their intended improvements that support Safeguards *services* processes:

- **SG Authorization Management (AM) system:** Optimization of this central access management system to ensure that authorized departmental staff members have easy access to safeguards information on a 'need to know' basis.
- **Geo-Based Data Integration (GDI) system:** Improve system performance and geographic visualization of safeguards data; further integrate GDI data with other applications to enhance field activity reporting; automate linking of GDI data with Additional Protocol declarations.
- **Safeguards Master Data (SGMD) system:** Enhance integration of facility- and site-specific holidays with other applications; improve, search and reporting capabilities (in collaboration with SGTS-014 and SGCP-102).
- **Support Programme Information and Communication System (SPRICS):** Improve user experience based on feedback from internal and external users; automated monitoring of system health checks; enhance audit management capabilities to track changes of the data; improve collaboration and communication features.

Applications and their intended improvements that support Safeguards *State-Cooperation* processes:

- **Additional Protocol System (APS):** Improve the usability with a user-centric dashboard; better integration with Geo-Based Data Integration (GDI) to show locations of sites and buildings (in collaboration with SGIM-002).
- **State Declarations Portal (SDP):** Strengthen archive management capabilities; secure outgoing correspondence capabilities and improve capability for States to submit additional types of data (in collaboration with SGIM-009).
- **State Supplied Data Handling (SSDH):** Automate workflows for exemption/de-exemption requests to replace a manual process; capability to track requests to States for declaration corrections and enhance transit matching activities.
- **Protocol Reporter 3 (PR3):** Improve integration between Protocol Report 2 (PR2), Protocol Reporter3 (PR3) and the APS tool.

Applications and their intended improvements that support Safeguards *verification* processes:

- **Containment Data Management System (CDMS):** Implement new quality checks for electronic seals recordings; improve usability for IAEA inspectors using the electronic Seals Working Paper; implement technical upgrades to support SGTS seal-initialization equipment.
- **Integrated Scheduler and Planner (ISP):** Improve integration of training materials; improve security, performance and stability; integrate with the United Nations Security Management System (UNDSS) data in the Agency-wide Information System for Programme Support (AIPS) for a more timely security clearance process.
- **Safeguards Field Reporting and Evaluation (SAFIRE):** Improve integration with other applications; improve performance, maintainability and capability to provide a smarter offline solution for IAEA inspectors to use in the field.
- **State Level Data Configurator (SLDC):** Improve user experience and system performance, including better support for departmental staff members conducting Acquisition Path Analysis.
- **Safeguards Effectiveness and Evaluation Information System (SEEIS):** Enhance capabilities to support the evaluation of activities at the State level; improve performance, usability and integration with the State Level Data Configurator (SLDC) for SLA information and the tracking of issues and follow up actions.
- Departmental staff members interface with and rely upon safeguards-tailored IT applications to meet the Department's mission. Enabling SGIS to effectively maintain these systems and constantly refine the Safeguards' IT platform will thus have a positive impact on the working conditions and ultimately the effectiveness and efficiency of the Department. The Department is requesting funds to sustain the IT upgrades made during MOSAIC and incrementally update its IT platform further in a manner that ensures the security and agility of the Department's IT infrastructure. Without this investment, the Department runs a higher risk of needing another massive effort to upgrade the hardware and software within the next 5–7 years. The work envisaged under this project will require the technical and financial support of multiple MSSPs to further develop Safeguards IT systems and/or provide expertise to SGIS. Support for this project could also provide SGIS access to training or collaborative opportunities that helps its staff refine their IT skills and acquire knowledge to be more effective and efficient while keeping Safeguards IT up-to-date. MSSPs who accept MSSP task proposal 18/GIS-002 (Keeping Safeguards IT Updated) provide resources for the enhancement of existing Safeguards IT capabilities.

Note: Multiple other D&IS project managers have planned IT developments in applications not listed above. When IT development is supported by a MSSP, the D&IS project manager will collaborate with SGIS-003 to ensure compliance with SGIS IT governance, standards and best practices. The alignment of IT development across the departmental facilitates the integration, integrity, security and availability of safeguards data.

Expected outcome #2

Further optimization of departmental processes through the identification and development of new IT capabilities.

Supporting R&D Needs: T.4.R1, V.4.R1, V.1.R3 and V.1.R1

Key Outputs

Expected Completion Date

New IT products in line with Departmental strategic priorities to optimize processes and improve the delivery of IT services with capabilities for the storage, retrieval and analysis of SG data. December 2021

Plans for accomplishing the expected outcome

To achieve the expected outcome, departmental staff members submit their needs and ideas for new projects through the established IT governance, which includes a review by the Safeguards IT Sub-Committee (SIT). In 2019, the following projects were approved by SIT for implementation in the 2020-21 biennium:

- **Technical Assistance Review System (TARS):** A modernized tool with new features for SGIM Analysts effectively and efficiently review IAEA Technical Assistance projects (in collaboration with SGIM-003). MSSP task USA D 2460 (Updating software to support Safeguards Review of IAEA Technical Assistance) provides resources to help develop the software to deliver the project objectives.
- **Smart Document Management System (HANA):** A new efficient, easy-to-use smart document management system. Collected and analysed system requirements; developed and implemented new capabilities to create, publish, link, search and display documents (in collaboration with SGCP-101).
- **SGTS Service Management Tool (SMT):** An enterprise level service management tool to enhance the service experience, increase productivity and achieve new insights in SGTS service to the Department. Implemented new incident management capabilities for SGTS Service Desk to improve and standardize the processes for service delivery; in other words, management of equipment and service requests with the capability to measure and manage key performance indicators (KPIs).
- Departmental staff members need new IT capabilities to continue to meet the Department's mission. Enabling SGIS to implement new IT capabilities will thus have a positive impact on the working conditions and ultimately the effectiveness and efficiency of the Department. Similarly to Expected Outcome #1, the Department is requesting funds to develop new IT features and incrementally update its IT platform further in a manner that ensures the security and agility of the Department's IT infrastructure. The work envisaged under this project will require the technical and financial support of multiple MSSPs to further develop new IT capabilities and/or provide expertise to support SGIS. MSSPs who accept MSSP task proposal 18/GIS-002 (Keeping Safeguards IT Updated) can provide resources for the development of new Safeguards IT capabilities.

5. Attachments

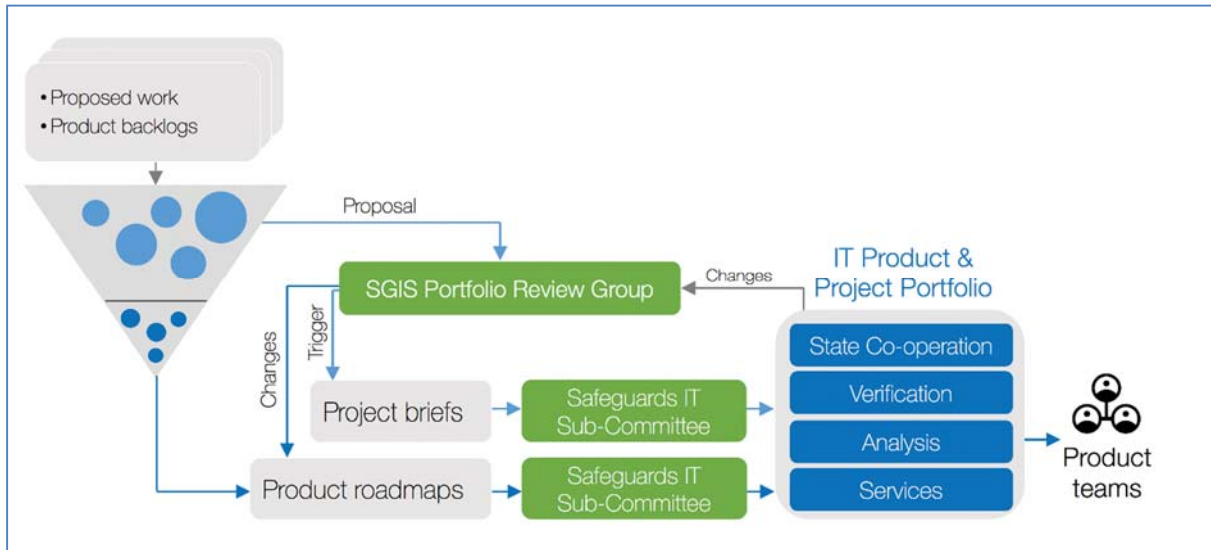

Figure 40: Safeguards IT Governance, the channel for departmental staff members to propose new ideas.

SGOA-002: Safeguards System for JNFL MOX Fuel Fabrication Plant (J-MOX)

Project Manager: Christophe CREUSOT

1. Overview

This chapter describes the plans for developing and implementing an effective and efficient safeguards system for the Japan Nuclear Fuel Ltd. (JNFL) MOX Fuel Fabrication Plant (J-MOX).

Project objective

The Japan Nuclear Fuel Ltd. (JNFL) 1 site, located in north Japan, currently includes the large-scale Rokkasho reprocessing plant (RRP). In the future, the site will incorporate a number of additional facilities, including a mixed oxide (MOX) fuel fabrication plant (J-MOX); additional uranium trioxide (UO₃) storage and various low-level-waste treatment and storage facilities.

The overall objective is to continue the development and implementation of the J-MOX safeguards systems. This includes the development of joint-use equipment; data collection systems and evaluation software, all of which is monitored through the J-MOX Joint Technical Committee (JTC), which involves all stakeholders, including Japanese State Authorities and the facility operator. The development has been predominantly on stand-by since 2013, as a result of construction postponements. The latest information published by the plant operator indicates that the facility is scheduled to commence operation, at the earliest, in 2022. However, construction can restart only after a safety review, which is ongoing and may delay the planned start date.

It is expected that most of the funding for development and implementation of the safeguards verification systems for J-MOX will come from the Department's regular budget. Member State Support Programme (MSSP) activities will be requested to focus on specific areas, including support to the development and testing of equipment and software dedicated to the J-MOX facility.

Foreseen challenges

The preliminary design information for J-MOX was submitted in June 2005. Plant construction commenced in October 2010 but was suspended following the major earthquake and tsunami that struck Japan on 11 March 2011. Construction restarted in April 2012, mainly dealing with the foundations of the main process building and the completion of the utilities building. Construction currently awaits further authorization by the safety authorities. The safety review is being performed based upon updated safety regulations, introduced following the accident at Fukushima Daiichi, which might impact the current design of J-MOX.

Because of the delays in construction, limited efforts were devoted to J-MOX development and implementation activities in the previous biennium. This plan for 2020–2021 will therefore remain largely unchanged from the previous biennial plan, as construction has not yet restarted as of the end of 2019.

The uncertain future of the plant provides a major challenge to planning resources for this project.

Top project priorities in 2020–2021

Subject to J-MOX construction resuming during the 2020–2021 biennium, the project's top priorities will be to:

- Develop/consolidate a safeguards approach consistent with the State Level Approach (SLA) for Japan.
- Develop/procure equipment necessary to support the safeguards approach.
- Define the requirements specification and architecture for an integrated data collection and evaluation system.

2. Strategy framework linkages

IAEA's Programme and Budget project linkage

The plan and MSSP tasks detailed in this chapter are followed-up and/or coordinated by Agency staff and are aligned with the objectives of the Agency's project #4.3.3.001 Develop and implement a safeguards approach for J-MOX in the *Agency's Programme and Budget 2020–2021*.

Safeguards Research & Development Plan linkage

Priority Objective	R&D Needs
T.1 Enable improved infield verification capabilities	T.1.R3 Assess existing techniques to detect misuse of reprocessing plants (real time detection of Pu separation).
	T.1.R5 Develop improved tools and techniques to enable real time flow measurements of nuclear material, including UF6 at enrichment plants and conversion plants, and Pu at reprocessing plants.
T.5 Identify and exploit innovations	T.5.R8 Develop alternative fast neutron detectors that improve effectiveness and fieldability.
V.5 Employ fit-for-purpose and state-of-the-art methodologies	V.5.R3 Explore data analysis methods and tools to strengthen the synthesis and evaluation of information (for example, optimal random verification schemes, nuclear material flow analysis, material balance evaluation, near real-time accountancy and process monitoring tools).

Collaborating D&IS projects

- SGAS-001: Destructive Analysis of Nuclear Materials
- SGIS-003: Safeguards Information Systems and System Usability
- SGIM-008: Statistical Analysis
- SGTS-001: NDA Techniques
- SGTS-003: Surveillance Techniques
- SGTS-011: Unattended Measurement Techniques
- SGTS-014 Remote Monitoring and Data Processing Systems

3. Progress on expected outcomes, key outputs and tasks from the previous biennium

Expected Outcome #1 from the 2018–2019 Biennium		
Developed effective and efficient safeguards approach and procedures for J-MOX.		
Supporting Priority Objective: V.5		
Key Outputs	Status	Comments
Safeguards approach for J-MOX, based on the basic elements agreed with Japan.	On hold	Pending the resumption of construction.
DIE/DIV procedures that assure that the facility is constructed and will operate as declared, while ensuring that the safeguards approach remains adequate and robust.	On hold	Pending the resumption of construction.

Expected Outcome #2 from the 2018–2019 Biennium		
Developed, tested and deployed verification systems at facilities to meet safeguards requirements.		
Supporting R&D Needs: T.1.R3, T.1.R5, T.5.R8 and V.5.R3		
Key Outputs	Status	Comments
Designed, tested and installed safeguards equipment (NDA, C/S) that provides high quality, independent and reliable results.	Delayed; work in progress	Conceptual design of a fuel rod verification system and prototype of a new data shift register was carried out during the 2018–2019 biennium.
Designed, tested and implemented integrated data collection and evaluation software for J-MOX, using synergies with the RRP Information System.	On hold	Pending the resumption of construction.

4. Expected outcomes, key outputs and tasks for the 2020–2021 biennium

In order to achieve overall objectives and meet R&D needs, tasks must be initiated, continued and/or finalized during the 2020–2021 biennium. The following expected outcomes serve as an outline for the next 2 years.

Expected outcome #1	
Developed effective and efficient safeguards approach and procedures for J-MOX. Supporting R&D Need: V.5	
Key Outputs	Expected Completion Date
Safeguards approach for J-MOX, based on the elements agreed with Japan.	Dependent upon construction decisions and commissioning schedule
DIE/DIV procedures that assure that the facility is constructed and will operate as declared, while ensuring that the safeguards approach remains adequate and robust.	Dependent upon construction decisions and commissioning schedule

Plans for accomplishing the expected outcome

A safeguards approach needs to be developed for J-MOX based upon the elements agreed with Japan. This approach will be in line with the Japan State Level Approach (SLA). The preparation of implementation procedures tailored for J-MOX will then be started and negotiated with the State Authorities and the facility operator.

As soon as the construction of the plant restarts, Design Information Examination (DIE)/Design Information Verification (DIV) procedures can be established and implemented in order to provide assurance that the facility is constructed and will operate as declared and to ensure that the safeguards approach remains adequate and robust. The DIE/DIV activities will be conducted from construction to MOX commissioning phases.

MSSP task UK D 1878 (Development of a Software Tool to Simulate the Nuclear Material Accountancy System for MOX Facilities) (completed in 2017) provided a software tool to simulate the nuclear material accountancy system at a typical MOX plant. This will facilitate the IAEA's review of the J-MOX operator's accountancy system design, which helps in the design phase to evaluate the effectiveness of the IAEA's verification system and Near Real Time Accountancy (NRTA) tools.

Additional MSSP support may be requested in the future for further development of NRTA simulation tools, as well as for the development of destructive analysis (DA) sample treatment, analysis and transportation procedures.

Expected outcome #2	
Developed, tested and deployed verification systems at facilities to meet safeguards requirements. Supporting R&D Needs: T.1.R3, T.1.R5, T.5.R8 and V.5.R3	
Key Outputs	Expected Completion Date
Designed, tested and installed safeguards equipment (NDA, C/S) that provides high quality, independent and reliable results.	Dependent upon construction decisions and commissioning schedule
Designed, tested and implemented integrated data collection and evaluation software for J-MOX, using synergies with the RRP Information System.	Dependent upon construction decisions and commissioning schedule

Plans for accomplishing the expected outcome

Under this project, several MSSPs have contributed to the design and testing of safeguards verification systems for JNFL J-MOX through a range of tasks. These tasks are intended to provide support that includes:

- Expert review of hardware (HW) and software (SW) designs
- Assistance with developing and testing new systems (non-destructive assay (NDA), integrating containment and surveillance (C/S) components and identification (ID) readers)
- Assistance with configuring an integrated data acquisition and evaluation system
- Assistance with developing, testing and configuring evaluation software modules

The potential for further activity under the various tasks of this project, some of which are currently active whilst others are on stand-by pending progress on J-MOX construction, is as follows:

- Tests with a number of equipment items (EMC-HPGe, a lanthanum bromide (LaBr) detector, liquid scintillator neutron detectors and magnetometers) were performed in March 2012 under MSSP task FRA A 1944 (Support for the Safeguards Systems at the JNFL MOX Fuel Fabrication Plant) to validate the conceptual design for the J-MOX fuel rod verification system. Additional tests are foreseen at MELOX (a manufacturer of MOX fuel assemblies in France) in late 2019 or 2020, in particular to test the prototype fuel rod verification system with actual MOX rods at an operational facility.
- Under MSSP task JPN A 1721 (Support for Development of J-MOX SG Systems), initial tests were conducted in 2013 to evaluate the potential use at J-MOX of new generation detectors (in other words, electromechanically-cooled high-purity germanium (EMC-HPGe), Cadmium zinc telluride (CZT) and liquid scintillator neutron detectors) as well as the long-term testing of the EMC-HPGe. Tests of a new Multi-Channel Multiplicity Counter Shift Register (MCSR) and a second type of EMC-HPGe were carried out in an existing Japanese MOX facility in 2018–2019.
- The Advanced Material Accountancy Glove Box (AMGB) system is one of the key NDA systems developed by the IAEA for J-MOX. Following a peer-review of its conceptual design under MSSP task USA A 1801 (Support for the Safeguards Systems at the JNFL MOX Fuel Fabrication Plant), a prototype of the AMGB system was produced in 2010 under the contract with the MAGB supplier (BOT Engineering) and was tested at the Joint Research Centre (JRC)-Ispra from 2011–2013 under MSSP task EC A 1778 (Support for the Safeguards Systems at the JNFL MOX Fuel Fabrication Plant). A peer review of a conceptual design for a fuel rods verification system was carried out in 2015 and 2018 under the same two tasks. Refinement and integration of the system continues in preparation for the MELOX tests.

Further MSSP support may be needed in the future for peer review of systems and prototype testing. For example, MSSP tasks USA D 1802 and EC D 1779 (Support for the Data Collection and Evaluation System (JADE) at the JNFL MOX Fuel Fabrication Plant) were accepted at the end of 2008 to provide assistance for the design, development, procurement, testing and installation of the J-MOX data collection and evaluation system. The development and implementation of this integrated system is currently on hold. High-level user requirements were gathered in 2010–2011, but subsequent steps will depend upon an updated J-MOX schedule. The IAEA will re-activate work and/or define sub-tasks as needs arise in collaboration with project SGIS-003: Safeguards Information Systems and System Usability.

5. Attachments

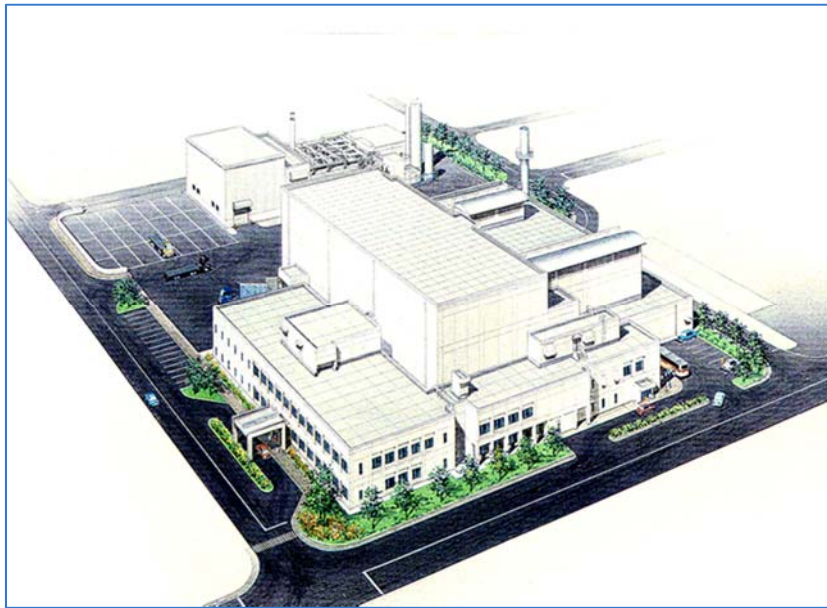

Figure 41: A bird's eye view of the future J-MOX plant



Figure 42: Testing of the fuel rod scanning system prototype

SGOA-003: Fukushima Dai-ichi Safeguards

Project Manager: Bruno CHESNAY

1. Overview

This chapter describes the plans for developing and implementing Fukushima Dai-ichi Safeguards for the 2020–2021 biennium.

Project objective

SGOA-003 is intended to facilitate the maintenance of safeguards at the Fukushima Dai-ichi site.

At the time of the earthquake and tsunami that struck Japan in March 2011, there were six large nuclear power reactors on the Fukushima Dai-Ichi site, as well as two spent fuel storage facilities—one pool-type and one dry-cask-type. All of the facilities were under IAEA safeguards and in full compliance with all relevant safeguards requirements.

The tsunami caused considerable damage to facilities and safeguards equipment. IAEA inspectors were first able to enter the damaged site in October 2011 to re-establish safeguards to the extent possible. Safeguards surveillance was re-established in accessible locations, and nuclear material was re-verified, in stages, as infrastructure was restored and as nuclear material was gradually removed from high-radiation areas. By the end of 2017, the nuclear material inventories of Reactor Units 4, 5 and 6, as well as the inventories of both spent fuel storage facilities, had been fully re-verified. The inventories of Reactor Units 1, 2 and 3 remained inaccessible.

The overall objective during the 2020–2021 biennium is to develop safeguards equipment and approaches for maintaining safeguards on the inaccessible nuclear material and facilities.

Foreseen challenges

Currently, there remains no access to the damaged cores and little knowledge, if any, of the precise location and form of nuclear material within them. This makes it difficult to begin the design of safeguards equipment in the near future.

In addition, remediation work can only progress slowly. Many years will be needed before retrieving even the undamaged fuels from the spent fuel ponds of units 3, 2 and 1 is practical. For the interim period, measures are required to enable monitoring of any removal of nuclear material from a changing and challenging environment.

Top project priorities in 2020–2021

- Maintain a reliable safeguards system at the Fukushima Dai-ichi site, capable of providing credible assurance that nuclear material cannot be removed from the damaged facilities without the IAEA's knowledge.
- Make improvements and adjustments to the monitoring system, to accommodate changes in the remediation status of the damaged facilities on the site.
- Develop measures to re-verify the previously inaccessible nuclear material as soon as material is made available for verification.

2. Strategy framework linkages

IAEA's Programme and Budget project linkage

The plan and MSSP tasks detailed in this chapter are followed-up and/or coordinated by Agency staff and are aligned with the objectives of the Agency's project #4.1.2.001 Verification for States with CSA and AP in force in the *Agency's Programme and Budget 2020–2021*.

Safeguards Research & Development Plan linkage

Priority Objective		R&D Needs	
P.4	Maintain readiness for other verification tasks	P.4.R2	Assist with Chernobyl and Fukushima related activities as requested.

Collaborating D&IS projects

- SGIS-003: Safeguards Information Systems and System Usability
- SGTS-001: NDA Techniques
- SGTS-002: Techniques and Instruments for Sealing and Containment Verification
- SGTS-011: Unattended Measurements Techniques
- SGTS-014: Remote Data Transmission and Processing Systems

3. Progress on expected outcomes, key outputs and tasks from the previous biennium

Expected Outcome #1 from the 2018–2019 Biennium		
Specialized support and expertise on monitoring systems capable of providing credible assurance that nuclear material is not removed from the damaged facilities (in close collaboration with SGTS-001 and SGTS-002).		
Supporting R&D Need: P.4.R2		
Key Outputs	Status	Comments
Design, development and deployment of reliable and effective monitoring systems using surveillance devices, radiation detectors or other methods	Key output achieved; work continues	The Open Air Spent Fuel Monitor (OASM) has been commissioned and provides assurance that no significant quantities of nuclear material are removed from the damaged units. Several cameras have been installed at different locations to cover Units 2 and 3, as work progresses to remove spent fuel from the ponds. Additional surveillance systems may be installed as the remediation works progress.
Expected Outcome #2 from the 2018–2019 Biennium		
Specialized support and expertise on technical options for in-situ verification of currently inaccessible material (in close collaboration with SGTS-001).		
Supporting R&D Need: P.4.R2		
Key Outputs	Status	Comments
Design and development of new verification techniques (in other words, non-destructive analysis based, optical devices, etc.) for in-situ verification of nuclear material (particularly spent fuel) at the damaged facilities	Cancelled	Access to the spent fuel ponds is still prohibited by high radiation levels.
Expected Outcome #3 from the 2018–2019 Biennium		
Enhanced knowledge about the status of the nuclear material in the damaged cores through an independent analysis of all available information to date.		
Supporting R&D Need: P.4.R2		
Key Outputs	Status	Comments
A report, based on the compilation of all relevant information published after the accident and the analysis of this data, to assess the status and the approximate location of the nuclear material in the reactor buildings	Cancelled	No new information is expected to provide additional knowledge on this topic.

4. Expected outcomes, key outputs and tasks for the 2020–2021 biennium

In order to achieve overall objectives and meet R&D needs, tasks must be initiated, continued and/or finalized during the 2020–2021 biennium. The following expected outcomes serve as an outline for the next 2 years.

Expected outcome #1	
Ability to provide credible and reliable assurance that nuclear material is not removed from damaged facilities; by designing, developing and deploying monitoring systems using surveillance devices, radiation detectors or other methods, with specialized support and expertise on monitoring systems. (In close collaboration with SGTS-001 and SGTS-002).	
Supporting R&D Need: P.4.R2	
Key Outputs	Expected Completion Date
Improve the OASM review software.	December 2020
Install/replace surveillance devices.	Continually

Plans for accomplishing the expected outcome

Currently, the IAEA's safeguards approach is to monitor the perimeter of the damaged reactor area—to ensure that no nuclear material can be removed from the damaged facilities without IAEA knowledge—and to supplement this monitoring with short-notice access to relevant locations on the site, to ensure that no undeclared activities are taking place.

The Japan Safeguards Office (JSGO), the Japanese safeguards authority, provides supplementary access rights and submits supplementary safeguards-relevant information to help the IAEA maintain adequate confidence that the declared nuclear material remains on the site. (The IAEA and the Japanese authorities meet formally twice each year, in the Fukushima Safeguards Task Force, to review the status of safeguards at the site.)

As remediation work continues at Fukushima Dai-ichi, infrastructure is being restored and radiation levels reduced. The IAEA will need to adjust and improve its monitoring systems to take account of these developments. Activity under this project follows on from OASM commissioning and installation during the 2018–2019 biennium and is expected to be completed together with the installation of new surveillance devices using regular budget resources and in collaboration with project SGIS-003: Safeguards Information Systems and System Usability. However, in addition to continued collaboration with the JSGO, specialized support and expertise on monitoring systems may also be required from the MSSPs.

Expected outcome #2	
Effective and efficient safeguards approaches are implemented for the Fukushima Dai-ichi site that include measures applicable to removed fuel-containing debris.	
Supporting R&D Need: P.4.R2	
Key Outputs	Expected Completion Date
A drafted Safeguards Approach, with specific implementation procedures applicable to the new facilities and material handling involving the removal of nuclear fuel bearing debris.	December 2020
A developed verification concept based on supporting facility preliminary design information and applicable to removed nuclear fuel bearing debris that may be containerized and processed through a hot cell.	December 2021

Plans for accomplishing the expected outcome

Due to high levels of radiation and damaged infrastructure, it has not been possible since the accident in 2011 to verify some of the nuclear material at Fukushima, and it is expected that significant amounts of nuclear material will remain inaccessible to verification for many years. The facility operator has plans to take small samples of fuel containing debris in 2020, followed by larger samples in later years. Eventually, all fuel containing debris and any intact fuel materials removed from the damaged reactor units are planned for storage on site.

The first small-scale sampling of fuel containing debris from the damaged reactor units, specifically from Unit 2, is planned by the facility operator for 2020. Additional plans involve the start of

construction of an on-site laboratory, in 2021, that will have hot cell capabilities to handle larger samples (up to 5 kilograms) of fuel containing debris.

Removed nuclear materials from the damaged reactors are intended for long-term storage on the Fukushima Dai-Ichi site. The nuclear material removal phases will require either the application of containment and/or surveillance measures or the verification of the material with appropriate non-destructive assay (NDA) methods. The IAEA also wishes to investigate options for in-situ verification of currently inaccessible nuclear materials, mainly spent fuel in the pools of Reactor Units 1, 2 and 3.

A drafted Safeguards Approach, with specific implementation procedures applicable to the new facilities and material handling involving the removal of nuclear fuel bearing debris (key output #1), is expected to be developed in-house.

External support and expertise from MSSPs will be requested to support a verification concept based upon facility preliminary design information, to include methodologies and techniques to verify the mass of recovered material, and to enable it to be compared against the initial cores of the damaged reactor units. A MSSP task proposal is being drafted for that purpose.

SGOC-001: Chornobyl

Project Manager: Sigitas KURSELIS

1. Overview

This chapter describes the plans for further development and implementation of safeguards at the Chornobyl site during the 2020–2021 biennium.

Project objective

The overall objective is to complete the development of and implement effective and efficient safeguards systems at the Interim (dry) Spent Fuel Storage Facility 2 and the associated Conditioning Facility (collectively referred to as 'ISF-2') and at the New Safe Confinement (NSC), placed over the existing Shelter that covers the Chornobyl Nuclear Power Plant (ChNPP) Unit 4. The IAEA's obligation is to ensure that safeguards are applied, in accordance with the terms of the safeguards agreement (INFCIRC/550), on all nuclear material at these facilities, while avoiding undue interference in the operations of the facilities.

Foreseen challenges

Over the course of 2–4 years, at the beginning of operation of ISF-2 and NSC, a high presence of on-site IAEA inspectors will be required because implementing safeguards—including adjusting procedures and equipment operation for the unique facilities—will be challenging and more time-intensive than for other facilities. After routine operation is started and procedures have been adjusted, the need for the presence of inspectors should reduce.

Top project priorities in 2020–2021

- Implement and adjust procedures for safeguards application at facilities under this project.
- Complete the adjustment of safeguards equipment for verification use at ISF-2.
- Complete the installation, adjustment and approbation of safeguards equipment for verification use at NSC.

2. Strategy framework linkages

IAEA's Programme and Budget project linkage

The plan and MSSP tasks detailed in this chapter are followed-up and/or coordinated by Agency staff and are aligned with the objectives of the Agency's project #4.3.3.003 Develop and implement safeguards approaches for the Chornobyl NPP in the *Agency's Programme and Budget 2020–2021*.

Safeguards Research & Development Plan linkage

Priority Objective	R&D Needs
P.4 Maintain readiness for other verification tasks	P.4.R2 Assist with Chornobyl and Fukushima related activities as requested.

Collaborating D&IS project

- SGTS-014: Remote Monitoring and Data Processing Systems

3. Progress on expected outcomes, key outputs and tasks from the previous biennium

Expected Outcome #1 from the 2018–2019 Biennium		
Finalized procedures for safeguards application at facilities under this project. Supporting R&D Need: P.4.R2		
Key Outputs	Status	Comments
Finalized procedures covering:		
Spent Fuel (SF) transfer from the wet storage at ChNPP to the ISF-2 conditioning facility	Key output achieved; work continues	The procedures are prepared and will be tested during hot test of the facility.
Flow of nuclear material inside the conditioning facility	Key output achieved; work continues	
Transfer of spent fuel from the conditioning facility to the dry storage	Key output achieved; work continues	
The dry spent fuel storage	Key output achieved; work continues	
Activities at the NSC	Delayed; nearing completion	The delay is caused by delay of construction of the NSC and lack of information regarding further facility operator's activities.

Expected Outcome #2 from the 2018–2019 Biennium		
Completed installation, adjustment and authorization of safeguards equipment for verification use (in close collaboration with SGTS-014). Supporting R&D Need: P.4.R2		
Key Outputs	Status	Comments
Approbation of safeguards equipment for verification use at ISF-2	Delayed; nearing completion	Testing of the installed equipment will be possible when transfer of the SF starts in early 2020.
Installation and approbation of safeguards equipment for verification use at NSC	Delayed; work in progress	The delay is caused by delay of construction of the NSC and lack of information regarding further facility operator's activities.

4. Expected outcomes, key outputs and tasks for the 2020–2021 biennium

In order to achieve overall objectives and meet R&D needs, tasks must be initiated, continued and/or finalized during the 2020–2021 biennium. The following expected outcomes serve as an outline for the next 2 years.

Expected outcome #1	
Safeguards are applied in an efficient and effective manner through finalized procedures for safeguards implementation at facilities under this project. Supporting R&D Need: P.4.R2	
Key Outputs	Expected Completion Date
Implemented mailbox system for ISF-2.	July 2020
Approved verification procedures for ISF-2.	July 2020
Approved verification procedures for NSC.	July 2021

Plans for accomplishing the expected outcome

To apply safeguards in an efficient and effective manner, appropriate procedures are required. In August 2015, the principles of the safeguards approach to be applied during spent fuel transfers to the ISF-2 were approved; they were subsequently incorporated into the updated State Level Approach (SLA) for Ukraine, which came into force on 1 May 2017. Drafting of detailed procedures for application of safeguards during spent fuel transfer, processing and storage are completed and will be tested during hot tests of the facility. Testing, adjustment and final approval are to be completed by July 2020. This date depends on the results of a 'hot test' of spent fuel transfer to the ISF-2.

The facility operator of the NSC plans a year-long pilot operation, without movement of any objects from Unit 4 of the NPP. Testing of IAEA equipment and procedures will commence during this pilot operation, with the majority of testing following its completion.

MSSP support is required to finance SGTS and SGOC trips to Chernobyl related to testing and adjustment of procedures. Approximately ten person trips are foreseen in the first half of 2020 for ISF-2 and ten person trips in the second half of 2020 for NSC.

Expected outcome #2	
Enhanced ability to carry out verification activities using equipment that is installed, adjusted and approved for verification use (in close collaboration with SGTS-014).	
Supporting R&D Need: P.4.R2	
Key Outputs	Expected Completion Date
Equipment at ISF-2 is tested.	July 2020
Installation of equipment at the NSC is complete.	July 2021
Equipment at NSC is tested, adjusted and approved.	July 2021

Plans for accomplishing the expected outcome

The safeguards measures to be applied at ISF-2 will utilize an integrated monitoring system consisting of surveillance and neutron and gamma radiation detectors, which will be operated in unattended mode with remote data transmission. Surveillance and radiation detectors have been installed in the spent fuel conditioning facility, as well as on transfer equipment such as the railcar and the canister trolley. The equipment is now in cold test mode. To test equipment at ISF-2 by July 2020, the facility operator plans to conduct a hot test by June 2020. During this period, IAEA equipment will be tested and adjusted if necessary. These tasks will be coordinated with tasks in Project SGTS-014: Remote Monitoring and Data Processing Systems.

In 2006, safeguards equipment was installed at the Unit 4 Shelter; at the main access points of the existing shelter for the detection of movements of nuclear material out of the area. The equipment, comprising surveillance and non-destructive assay (NDA) devices, was upgraded in 2013. Part of this equipment will continue to be used, together with new monitoring equipment that is to be installed on the main entrances of the NSC. Installation of the new equipment should start in 2020. Full-scope testing (and adjustment if necessary) will be conducted when the facility operator begins the removal of contaminated objects.

For these tasks, MSSP support will be required, to finance SGTS and SGOC attendance at Chernobyl related to equipment installation at NSC and testing, adjustment and maintenance at both facilities. Approximately 20 person trips are planned during 2020. In addition, financing of equipment, consisting of portal monitors and surveillance, for the NSC has already been requested.

5. In-house development tasks

The table below lists internal development activities that will continue, but which will benefit from external contributions to the project. It gives an understanding of how external stakeholders can:

- Complement existing work
- Initiate activities in under-served areas of need
- Avoid duplicate activities

Expected outcome	Task #	Task Title (Agency's task cross reference)	Description	Expected Completion Date
1	1	Update mailbox system	Analysis of performance of the mailbox system after a few months of infield operation; update if needed	July 2020
1	2	Development of detailed procedures for ISF-2	Detailed procedures to be developed and approved	July 2020
1	3	Development of detailed procedures for NSC	Detailed procedures to be developed and approved	July 2021
2	4	Analysis of results of cold and hot tests at ISF-2	Analysis of results of tests during infield operation at ISF-2 will be performed.	July 2020
2	5	Analysis of results of cold and hot tests at NSC	Analysis of results of tests during infield operation at NSC will be performed.	July 2021

6. Attachments



Figure 43: Completed Chernobyl New Safe Confinement in April 2019



Figure 44: Completed Processing Facility of the Interim Spent Fuel Storage Facility 2

SGTS-001: NDA Techniques

Project Manager: Mikhail MAYOROV

1. Overview

This chapter describes the 2020–2021 biennium plans for developing and implementing non-destructive assay (NDA) methods and systems for the assessment and verification of nuclear material and instrumentation associated with other inspector field activities, such as design information verification and complementary access.

Project objective

The primary objective of the project is to pursue NDA developments with the highest priority given to tasks that improve present verification capability, reduce deficiencies and vulnerability of current equipment or address new safeguards needs.

Foreseen challenges

Member States may impose on the IAEA new safety requirements regarding the use of both existing and new NDA systems for verification at nuclear facilities. These requirements may vary from one State to another and can pose a significant challenge when requested to be met at short notice.

Top project priorities in 2020–2021

- Improve the effectiveness of NDA-based verification activities, without reducing their efficiency, through the application of:
 - Fast Neutron Coincidence Collar, for active⁷ and passive Partial Defect Test (PDT) verifications.
 - Passive Gamma Emission Tomography (PGET) System, in unattended mode.
 - Compact Tomographic Gamma scanner, for inhomogeneous nuclear scrap and waste.
- Enhance the capability for detecting undeclared material and activities, through:
 - Authorization for safeguards use of the Compton and coded aperture gamma camera.
 - Analytical characterisation of the remaining fifteen Nuclear Fuel Cycle (NFC) reference material samples.
- Apply new tools and techniques to routine operations:
 - Ultra-large volume Cadmium-Zinc-Telluride (CDZT) probes, for fresh material verification.
 - Inspector-level integrated data acquisition and analysis software application (MCAT).
 - Infield alpha spectrometers, for nuclear material identification and isotopic composition analysis.
 - Calorimeter, for assay of plutonium samples.
 - New procedures for verification of uranium at bulk facilities, including those based on High-resolution Gamma Spectrometry (HRGS); Raman spectrometry or Laser Induced Breakdown Spectrometry (LIBS).
- Undertake a feasibility study, of fast neutron scanning & imaging techniques for restoration of Continuity of Knowledge (CoK) on light water reactor (LWR) spent fuel casks.

⁷ Using radionuclide interrogation sources and/or a Deuterium-Deuterium (DD) neutron generator.

2. Strategy framework linkages

IAEA's Programme and Budget project linkage

The plan and MSSP tasks detailed in this chapter are followed-up and/or coordinated by Agency staff and are aligned with the objectives of the Agency's projects #4.1.6.001 Portable and resident non-destructive assay equipment and #4.3.2.001 Development of equipment components and stand-alone instruments in the *Agency's Programme and Budget 2020–2021*.

Safeguards Research & Development Plan linkage

Priority Objective	R&D Needs
T.1 Strengthen instrumentation capabilities for verification	T.1.R5 Develop improved tools and techniques to enable real-time flow measurements of nuclear material, including UF ₆ at enrichment plants and conversion plants, and Pu at reprocessing plants.
	T.1.R6 Develop safeguards equipment to establish and maintain knowledge of spent fuel in shielding/storage/transport containers at all points in their life cycle.
T.5 Identify and exploit innovations	T.5.R8 Develop alternative fast neutron detectors that improve effectiveness and fieldability.
	T.5.R9 Develop large room-temperature semiconductor medium-resolution gamma spectrometers to replace scintillation detector systems.

Collaborating D&IS projects

- SGIS-003: Safeguards Information Systems and System Usability
- SGTS-008: Instrumentation Technology Foresight
- SGTS-011: Unattended Measurements Techniques
- SGAS-001: Destructive Analysis of Nuclear Materials

3. Progress on expected outcomes, key outputs and tasks from the previous biennium

Expected Outcome #1 from the 2018–2019 Biennium		
Developed instruments and associated techniques to detect the establishment and operation of nuclear fuel cycle activities, for example by detecting process emanations.		
Supporting Priority Objective: T.5		
Key Outputs	Status	Comments
Results of assessment of capabilities of portable Laser induced breakdown spectrometer (LIBS) for impurity Content Determination in Uranium Bearing Material.	Key output achieved; work continues	Performance of two different LIBS systems (Prototype Portable LIBS System (PHHL) and LIBSCAN-25+) was evaluated. The work continues under MSSP task HUN A 2282 (Assessment of Capabilities of Portable LIBS for Impurity Content Determination in Uranium Bearing Materials).

Expected Outcome #2 from the 2018–2019 Biennium

Developed elemental and isotopic signatures of nuclear fuel cycle activities and processes for the calibration of instruments.

Supporting R&D Needs: V.5.R2

Key Outputs	Status	Comments
Repositories of basic nuclear fuel cycle indicator and signature materials, relevant infrastructure for carrying out experimental tests with such materials, and comprehensively-characterized collected materials.	Key output achieved; work continues	Repositories of 30 NFC indicators (metals only) were established under MSSP tasks UK A 2215 and USA A 2246 (Creation of a Repository of Nuclear Fuel Cycle Signature Reference Materials). Fifteen samples (Al-, Zr-, Ni-, Mg-, Be-, Cd-, Hf- alloys and steels) still require characterisation (elemental composition, specific impurity content, texture, porosity, etc.).

Expected Outcome #3 from the 2018–2019 Biennium

Developed improved instruments and techniques to address verification of waste and scrap nuclear material with impure composition or heterogeneous isotopic composition.

Supporting Priority Objectives: T.5 and T.1

Key Outputs	Status	Comments
Results of performance evaluation of the Compact Gamma Tomography System (delivered to the IAEA in 2017), with the goal of authorizing the system for inspection use.	Delayed; work in progress	To fully utilize the Compact Tomographic Gamma Scanner (CTGS) functions, methodological support was required. This was requested from Los Alamos National Laboratory and is being provided through MSSP task USA A 2369 (Implementation Support of Compact Tomographic Gamma Scanner for Verification of Containers).

Expected Outcome #4 from the 2018–2019 Biennium

Deployed more sensitive and less intrusive alternatives to existing instruments to perform partial defect test on spent fuel assembly prior to transfer to difficult-to-access storage.

Supporting Priority Objectives: T.5 and T.1

Key Outputs	Status	Comments
Deployment of a Passive Gamma Emission Tomography (PGET) for non-routine (EPGR) and routine (such as verification of dismantlable spent nuclear fuel) activities that require verification with partial defect test.	Key output achieved; work continues	The PGET has been authorized for method F (partial defect) and method E (bias defect) for Spent Fuel Assemblies (SFAs) from pressurized water reactors (PWRs); boiling water reactors (BWRs) and the water-water energetic reactor (WWER)-440. Since its authorization, PGET has been used twice for verification of closed containers. The use of PGET for SFA verification is foreseen for 2020 and beyond.

Expected Outcome #5 from the 2018–2019 Biennium

Deployed alternative NDA instruments (for instance, based on liquid scintillators) to improve performance in neutron coincidence counting techniques applied to various types of fissile material.

Supporting R&D Need: T.5.R8

Key Outputs	Status	Comments
Results of test and deployment of the re-designed fast neutron uranium collar (FNCL) at fuel fabrication plants where the nuclear fuel containing burnable poison rods is manufactured.	Key output achieved; work continues	The system has been successfully tested at 4 fuel fabrication plants (South Korea, Brazil, France and Sweden) on a large variety of nuclear fuel designs. Authorization of the FNCL for safeguards is scheduled for November 2019 [SG-RP-15380—FNCL Development Report]. Three new systems were procured for deployment in 2020. In 2020–2021, the IAEA plans to adapt the FNCL for assay of Pu samples.

Expected Outcome #6 from the 2018–2019 Biennium

Re-designed, improved or upgraded safeguards equipment and systems, implementing an improved cost/benefit assessment methodology for the design and operation of safeguards equipment.

Supporting Priority Objective: T.1 and T.5 **Supporting R&D Need:** T.2.R1

Key Outputs	Status	Comments
Re-designed Cask Radiation Profiling System (CRPS) to replace phased-out components of the old CRPS.	Key output achieved; work completed	The CRPS was fully re-designed. Ten new systems were procured and are being deployed for verification purposes.
COMPUCEA application extended towards UF ₆ enrichment.	Key output achieved; work completed	COMPUCEA was adapted for analysis of UF ₆ samples and deployed in one of the Member States for verification activities.
New fast neutron probe for performance of the zero-power reactor noise analysis for verification of research reactors and critical assemblies.	Key output achieved; work continues	Working in collaboration with the FNCL development team, a new single-channel stilbene-based system was developed and tested. Field deployment of the system is pending endorsement from the facility operator.
Re-designed ICVD to allow image recording and special processing to essentially enhance image quality. (In cooperation with SGTS-008)	Delayed; work in progress	The task is being implemented under SGTS-008.
Development of an Inspector-level integrated data acquisition and analysis software application.	Key output achieved; work continues	The Multichannel Analyser – Touch (MCAT) software application is being upgraded under MSSP tasks GER A 2278 (Upgrading of the MCA-Touch Software) and USA A 0931 (NDA Implementation Support - Instruments and Techniques). By end-2019, the implementation of four modules (LabPel, LabRod, WinMTR and Infinite Thickness) was completed. MCAT integration with a further three modules (FRAM, MGA/MGAU and WinTimeStamp) is continuing, according to the project plan, and will be completed in 2020.

4. Expected outcomes, key outputs and tasks for the 2020–2021 biennium

In order to achieve overall objectives and meet R&D needs, tasks must be initiated, continued and/or finalized during the 2020–2021 biennium. The following expected outcomes serve as an outline for the next 2 years.

Expected outcome #1	
Enhanced performance and usability of medium-resolution gamma spectrometry for nuclear material verification.	
Supporting R&D Need: T.5.R9	
Key Outputs	Expected Completion Date
Acquisition and performance evaluation of the ultra-large volume (up to 29 cm ³) Cadmium-zinc-telluride (CDZT) probe.	July 2020
Authorization of a large-volume segmented CDZT-based Compton and coded aperture gamma camera.	July 2020
Performance validation of the uranium enrichment determination codes for analysis of CDZT gamma spectra (NaIGEM, FRAM 6.0).	December 2020

Plans for accomplishing the expected outcome

One of the factors that has always limited the wider application of CDZT detectors for fresh material verification is its relatively low size (up to 1500 mm³). Despite the known benefits of CDZT-based gamma spectrometry—such as good energy resolution, linearity, stability and insensitivity to ambient temperature and magnetic fields—the application of CDZT probes has been limited to attribute testing of nuclear material.

Recent advances in the technology of manufacturing crystals with ultra-large volume—of up to 29 cm³—complemented by improved spectrometry of such probes, has promoted the development of CDZT probes. These are seen as the replacement for NaI(Tl) and LaBr₃(Ce) scintillating crystals coupled with photomultiplier tubes. Furthermore, the safeguards-specific software codes (NaIGEM, FRAM) are being adapted to exploit the performance of the CDZT probes for uranium enrichment measurements.

The expected benefits from using the CDZT probes will be enhanced spectrometric performance, better radionuclide identification and improved usability (size, stability, tolerance to influencing factors).

Expected outcome #2	
Improved NDA methodologies for verification of uranium at bulk facilities.	
Supporting R&D Need: T.1.R5	
Key Outputs	Expected Completion Date
Determination of uranium concentration (up to 20 wt%) and enrichment of in-process material using high-resolution gamma spectrometry.	March 2021
Determination of uranium concentration in aqueous uranyl sulphate solutions using Raman spectrometry.	December 2021
Assessment of capabilities of portable LIBS for impurity content determination in uranium-bearing materials.	December 2021

Plans for accomplishing the expected outcome

A number of activities are in progress, responding to requests from Operations Divisions to provide methodological support to verification of uranium at conversion and fuel fabrication facilities.

Using HRGS, simultaneous determination of uranium enrichment by infinite thickness and peak ratio methods⁸ allows the determination of uranium concentration, relative to a baseline concentration

⁸ The time after uranium separation is either known or considered long enough to reach equilibrium between U-238 and its decay products.

used for infinite thickness calibration. Work on the development and validation of this technique is in progress, in collaboration with SGAS/NML (responsible for the large number of reference samples required during the development and test phases).

Another method to determine uranium concentration in aqueous solutions of uranyl nitrate or uranyl sulphate employs Raman spectrometry. It has been shown that the solution density; its temperature; uranium concentration and enrichment and the intensity of characteristic Raman lines for UO_2^{2+} , NO_3^- and SO_4^{2-} are all connected. Hence, by measuring in-field the uranium enrichment (by gamma spectrometry with MGA/MGAU codes), the temperature and density of solution (using an analytical densitometer) and the Raman spectra, the concentration of uranyl may be determined. This technique has been successfully applied to uranyl nitrates and in 2020–2021, the intention is to determine calibration coefficients for uranyl sulphates and to validate the method in-field.

Another task will extend the knowledge and provide experimental data supporting analytical capabilities of the emerging LIBS technology. LIBS offers the potential for prompt in-field examination, enabling well-grounded decisions on the appropriateness of application of safeguards measures and the analysis of purity of nuclear materials, which can be used for identification of these materials and their origin. Experimental studies using real samples under MSSP task HUN A 2282 (Assessment of Capabilities of Portable LIBS for Impurity Content Determination in Uranium Bearing Materials) are intended to establish the capability of the technique. The deliverables of the task will be used to plan further steps towards implementation of the LIBS method, including selection and customization of related portable instrumentation, and measurement practices in support of in-field impurity analysis of uranium-bearing materials by inspectors or SGTS experts.

Expected outcome #3	
Improved instruments and techniques to address verification of waste and scrap nuclear material with impure composition or heterogeneous isotopic composition.	
Supporting R&D Need: T.1.1.R6	
Key Outputs	Expected Completion Date
Development of new data processing algorithm.	March 2020
Performance evaluation and authorization of CTGS.	July 2020

Plans for accomplishing the expected outcome

SGTS-001 will continue to promote activities associated with the evaluation and authorization of the Compact Tomographic Gamma Scanner (CTGS) for assessment of nuclear waste. The instrument was manufactured and delivered to the IAEA in 2016-2017 to address a particular verification challenge: the quantitative verification of heterogeneous waste and scrap containing nuclear material.

Neutron measurements may not be accurate enough to meet the specification for partial defect tests, since the matrix of the material (particularly with regard to hydrogen and neutron-absorbing compounds) is unknown and difficult to assay. An alternative solution is transmission-emission high-resolution gamma spectrometry performed at the level of individual voxels in the inspected object. Expertise for software development will be used to facilitate the authorization process.

MSSP task USA A 2369 (Implementation Support of Compact Tomographic Gamma Scanner for Verification of Containers) is active in providing detailed knowledge on how to efficiently and effectively run the TGS_FIT software package.

Expected outcome #4

Development and testing of new PGET capabilities.

Supporting R&D Need: T.1.R6

Key Outputs

Expected Completion Date

Development, testing and implementation of the algorithms and software modules required for the remote and unattended operation of PGET.

December 2020

PGET performance evaluation on VVER-1000.

November 2020

Plans for accomplishing the expected outcome

During 2018–2019 plan under MSSP tasks JNT A 2315 USA, 2272 SWE and 2258 FIN (Performance Evaluation and Implementation Support of Gamma Emission Tomography for Spent-Fuel Verification) work was successfully completed on development and validation of the numerical model of PGET; testing of the algebraic image reconstruction algorithm; and as an important step towards deployment of PGET at Olkiluoto Nuclear Power Plant (NPP), for verification of SFAs designated for underground repositories in Finland, the system was successfully assessed for its performance in verifying low burn-up and extremely long cooling time fuel.

Having established new capabilities for partial and bias defect test verification of LWR spent fuel assemblies and closed containers, this project is moving ahead with developing new PGET functionalities in collaboration with project SGIS-003: Safeguards Information Systems and System Usability. MSSP task FIN A 2258 (Performance Evaluation and Implementation Support of Gamma Emission Tomography for Spent Fuel Verification) has demonstrated that the system can be controlled remotely via a secured network from, for example, the IAEA or Euratom headquarters, but there is also a need to enable PGET operation in fully unattended mode. MSSP tasks FIN A 2258 will continue, in collaboration with SGTS-011, and with MSSP tasks JNT A 2414 FIN and 2463 SWE (Support for testing of PGET new functionalities in attended, remote and unattended modes) and USA A 2015 (Expert - Non Destructive Assay Specialist).

In 2020, PGET is scheduled to be evaluated on one of the most challenging SFAs: water-water energy reactor (VVER)-1000. This test will be performed under MSSP task JNT A 2453 RUS (Support for testing of PGET new functionalities in attended, remote and unattended modes) at Balakovo NPP.

Expected outcome #5

Capability to restore Continuity of Knowledge (CoK) on light water reactor spent fuel casks by fast neutron scanning & imaging techniques.

Supporting R&D Need: T.5.R8

Key Outputs

Expected Completion Date

Confirmation of feasibility by simulation studies (including validation of the numerical model) and experimental proof-of-principle demonstration (Decision point 1).

December 2020

Development of the user requirements; design and manufacturing of a prototype system.

December 2021

Field-testing (Decision point 2) and authorization for nuclear material verification, which is dependent on a successful performance evaluation.

December 2022

Plans for accomplishing the expected outcome

The IAEA plans to issue a new MSSP task proposal, seeking MSSP support to investigate viable solutions to restore Continuity of Knowledge (CoK) after failure of dual containment and surveillance (C/S) systems applied to LWR dry storage casks. Such solutions should allow the IAEA to drastically lower the level of redundancy currently applied to dual C/S arrangements.

The current probability of success is low because, to date, neutron imaging attempts have provided inconclusive results. However, a breakthrough may be anticipated with the availability of improved techniques for fast neutron detection. To mitigate the potential failure of the development, simulation studies will be completed, followed by experimental proof-of-principle, prior to seeking investment in construction of a high-cost demonstration instrument.

This project will be conducted in cooperation with Euratom, involving a combination of internal resources and MSSP tasks as necessary.

5. In-house development tasks

The table below lists internal development activities that will continue, but which will benefit from external contributions to the project. It gives an understanding of how external stakeholders can:

- Complement existing work
- Initiate activities in under-served areas of need
- Avoid duplicate activities
-

Expected outcome	Task #	Task Title (Agency's task cross reference)	Description	Expected Completion Date
Inspector-level integrated data acquisition and analysis software application	1355	Development of Inspection NDA Acquisition and Analysis Software Platform	Under this task, and in cooperation with GER A 2278 (Upgrading of the MCA-Touch Software) and USA A 0931 (NDA Implementation Support - Instruments and Techniques), the IAEA intends to coordinate and facilitate re-engineering of the MCAT software suite in a modular and expandable structure, to accommodate current features and future developments in a sustainable and user-friendly manner.	2020
Authorization of the fast neutron uranium collar (FNCL)	1387	Performance evaluation and authorization of the fast neutron uranium collar for partial defect test on fresh fuel	The objective of this task is to (1) Evaluate the performance of the existing prototype of the FNCL, which may prove an effective and improved solution for determination of U-235 mass density in fresh fuel assemblies containing burnable poisons; and, ultimately (2) authorize the FNCL for inspection use. The outcome of this task may be extended by application to other challenging issues, such as the assay of U waste within an unknown matrix.	2020
New NDA system for assay of inhomogeneous nuclear scrap and waste	1424	Performance evaluation and authorization of Compact Gamma Tomography System for nuclear waste assay	The IAEA with support from MSSP task USA A 2369 (Implementation Support of Compact Tomographic Gamma Scanner for Verification of Containers) will develop a methodology and perform evaluation of the Compact Gamma Tomography System with the goal to fully authorize the system for inspection use.	2020
Field-deployable alpha-spectrometer	1449	Feasibility study of nuclear material assessment with infield alpha spectrometry	The IAEA will perform feasibility studies and a pilot deployment of infield alpha spectrometers for nuclear material identification and isotopic composition analysis; and establish the necessary procedures for application of the	2021

			methodology within the Department.	
Ultra-large volume CDZT probe to replace NaI and LaBr3 detectors in the IAEA NDA toolbox	1761	Evaluation of handheld devices and stand-alone spectrometric probes based on large CZT sensors	The IAEA will evaluate the performance of ultra-large volume CDZT probes offering improved spectrometric performance.	2020
PGET with enhanced functionality and UGET	1814	Development and testing of new PGET capabilities	<p>The main activities under this task are:</p> <p>Revision of the procedures and test equipment for acceptance testing, maintenance and preparation for inspection of PGET.</p> <p>Testing and implementation of rod-counting and missing-pin-detection algorithms.</p> <p>Development, testing and implementation of the algorithms and software modules required for the remote and unattended operation of PGET.</p> <p>Completing a feasibility study and implementing the algorithms for quantitative analysis of nuclear material by a combination of MRGS with CZT and total neutron counting.</p>	2021
Built in-house capability to perform plutonium assay with calorimetry systems	1961	Introduction of calorimetric assay in the set of NDA methods available for safeguards verification	The task aims to introduce calorimetric assay as an NDA technique, available to support verification activities, for the quantitative assay of nuclear material. The target accuracy shall be, as a minimum, equivalent to the accuracy provided by other NDA methods (for example, neutron multiplicity counting).	2021

6. Attachments



Figure 45: Fast Neutron Uranium Collar (FNCL) Water-Water Energetic Reactor (WWER)

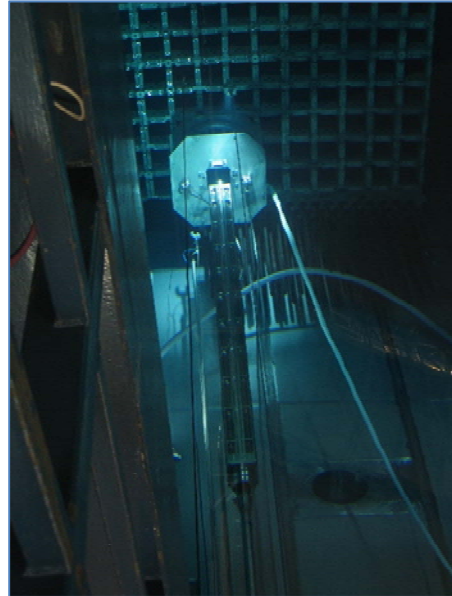

Figure 46: Passive Gamma Emission Tomography (PGET) Containers



Figure 47: Passive Gamma Emission Tomography (PGET) PNAR



Figure 48: Fast Neutron Uranium Collar (FNCL) Boiling Water Reactor (BWR)

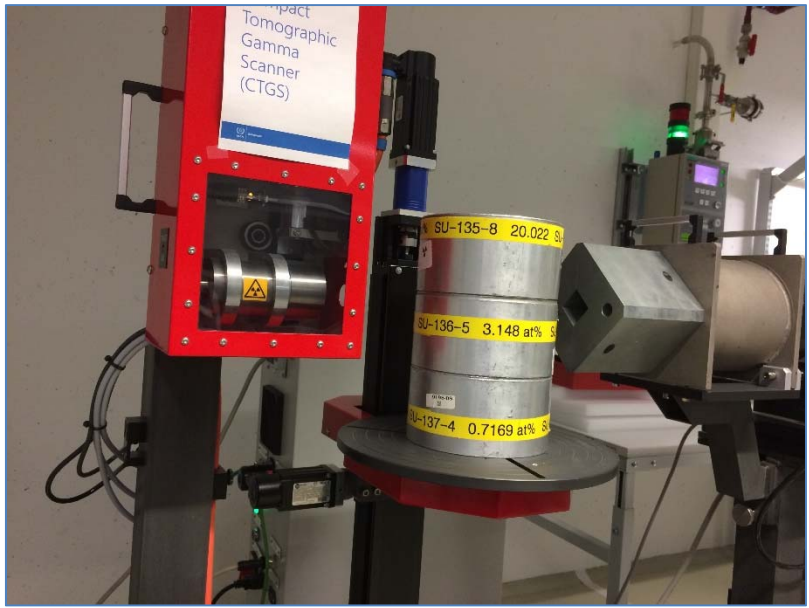

Figure 49: Compact Tomographic Gamma Scanner (CTGS)

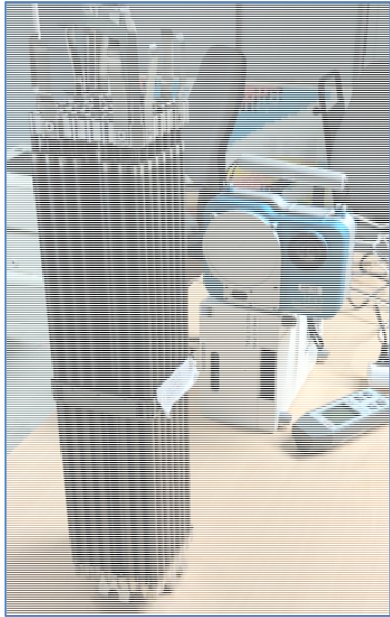
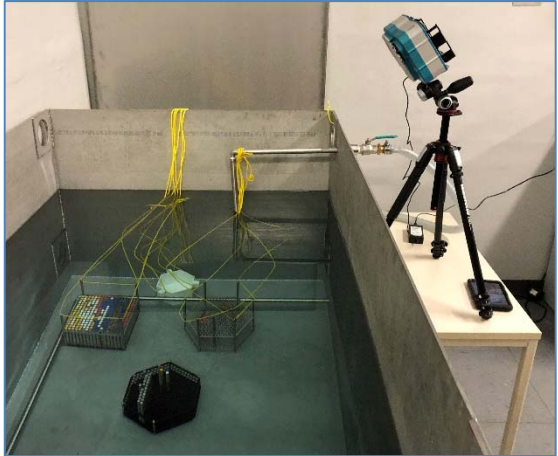

Figure 50 & Figure 51: Gamma cameras

SGTS-002: Techniques and Instruments for Sealing and Containment Verification

Project Manager: Bernie WISHARD

1. Overview

This chapter describes the plans for developing and implementing sealing and containment verification systems, as well as for identifying vulnerabilities in safeguards equipment and protecting the data security of all safeguards equipment, during the 2020–2021 biennium.

Project objective

The overall objective is to secure containment, which is essential to all safeguards approaches. Containment systems are required for every type of nuclear facility in the fuel cycle and at other locations under special bilateral agreements. However, traditional sealing arrangements are frequently resource-intensive and can expose inspectors to environmental risks.

The projected number of spent fuel in hard-to-access dry storage could triple in the next one to two decades. New containment innovations are needed to more effectively address this increase and other verification burdens. In addition, there is a need for increased security, as any gaps in the IAEA's ability to detect tampering can greatly impact its credibility and/or its ability for timely response. Therefore, enhanced security will continue to drive the need for better physical and cybersecurity features in containment and all other safeguards systems.

Emphasis will be placed on sealing systems that can reduce the requirements on the Department's resources: not only regarding installation, but also on maintenance/replacement activities and, especially, during verification activities. These elements are leading the IAEA to the development of active systems using laser, ultrasonic and radiofrequency techniques as containment mechanisms. Improving active systems' reliability; decreasing active systems' maintenance and extending battery lives for as long as possible will continue to be necessary to system success.

Finally, as part of the Safeguards Instrument Authorization process, all unattended safeguards systems must be assessed for vulnerabilities and those vulnerabilities must be mitigated to an acceptable level based on well-defined threat models. Therefore, security assessments are an important part of this plan.

Foreseen challenges

1. The projected increase of spent fuel casks by factors of 2 to 3 over the next decade(s) could lead to commensurate increases in verification efforts. Sealing individual casks in nominally static storage facilities are extremely resource-intensive, and maintaining current practices (without an increase in trained staff) appears to be untenable. Therefore, emphasis is on concepts for new approaches that implement perimeter sealing technologies and solutions, rather than individual or small groups of casks. These approaches will mostly utilize active systems with micro-controllers that can be monitored remotely.
2. The utilization of the E-CAP (metal seal) is very labour-intensive as it requires inspectors to tie knots or crimp sealing wires in radiation areas, as well as return these (occasionally contaminated) seals to IAEA headquarters for verification by a dedicated technical team. A replacement passive sealing technology should ideally reduce these processes. Developing the optimum combination of features will require a combination of material science and physical security expertise.
3. Active seals currently require extensive maintenance and low battery-life is a recurrent challenge. The IAEA would benefit from ultra-low power and energy harvesting research to improve battery performance, but lacks internal resources to do so.
4. The IAEA finds it increasingly challenging to facilitate third-party vulnerability assessments (VAs) of safeguards equipment, including containment systems. Long lead-times, with the potential that an adequate VAs cannot be completed for a variety of resource, technical or logistical reasons, challenges the Department's ability to introduce improved safeguards equipment and procedures in a timely manner. The development of a combination of other VA methods (for example, an internally developed vulnerability review (VR), combined with an external peer review) may prove to be a more effective approach. Such an approach is more in-line with scientific methodology and potentially more effective and timely in the delivery of results than past 3rd party VAs.

Top project priorities in 2020–2021

- Decreasing IAEA safeguards inspectors' effort in verifying containment on spent fuel storage through more flexible technologies.
- Decreasing efforts during DIVs by more efficient CoK of samples
- Improving the effectiveness and efficiency of passive seals.
- Improving security while decreasing maintenance demands for the replacement of the currently fielded Electronic Optical Sealing System (EOSS).
- Decreasing IAEA safeguards inspectors' exposure to radiation during containment verification of casks.

2. Strategy framework linkages

IAEA's Programme and Budget project linkage

The plan and MSSP tasks detailed in this chapter are followed-up and/or coordinated by Agency staff and are aligned with the objectives of the Agency's projects #4.1.6.004 Systems integration and coordination and #4.3.2.001 Development of equipment components and stand-alone instruments in the *Agency's Programme and Budget 2020–2021*.

Safeguards Research & Development Plan linkage

Priority Objective	R&D Needs
T.5 Identify and exploit innovations	T.5.R10 Develop new Sealing System Technologies with improved security and economy.

Collaborating D&IS project

- SGIS-002 Information Security and Infrastructure

3. Progress on expected outcomes, key outputs and tasks from the previous biennium

Expected Outcome #1 from the 2018–2019 Biennium		
Modernized and sustained sealing systems with increased tamper resistance are available for use in safeguards.		
Supporting R&D Needs: T.1.R6 and T.5.R10		
Key Outputs	Status	Comments
Results of field-testing of the Active Optical Loop Seal (AOLS).	Delayed; work in progress	Initial radiation testing of AOLS indicated insufficient tolerance in two components. Mitigation may require a redesign of the microcontroller, towards system on-chip technology. This design could improve performance, reduce power consumption and increase radiation tolerance.
Result of field-testing of the glass seal (GLAS).	A key output was achieved but work delayed. / Delayed; work in progress	About 300 prototypes of the GLAS seal were tested. Despite some success, a small fraction tested were determined to be too fragile. This has led to a re-evaluation of the design and an exploration for alternative treatments, materials and techniques.

Expected Outcome #2 from the 2018–2019 Biennium		
Developed and maintained sealing systems for facility-specific applications.		
Supporting R&D Need: T.5.R10		
Key Outputs	Status	Comments
Results of field testing of a Laser Curtain for Containment (LCCT).	Key output achieved; work continues	The LCCT was tested under MSSP task ARG A 2318 (2D laser sealing system test at RAD1) and in a second trial for functionality in collaboration with ABACC. The IAEA has provisionally authorized the LCCT for use at Atucha-1 dry storage silos, Argentina.

Laboratory and field testing of Universal UF ₆ Reader (UF ₆ R).	Delayed; work in progress	A portable reader, to authenticate UF ₆ cylinders based on their unique welds, was designed in collaboration with the European Commission Joint Research Centre (EC-JRC) under MSSP task EC E 1549 (Laser Surface Mapping of Canister Closure Welds). The system will be tested at an enrichment facility likely in the United States of America.
Release of new version of the Ultrasonic Optical Sealing Bolt (UOSB) and its reader, for more effectively implementing joint-use arrangements.	Key output achieved; work continues	Implementation of the UOSB at Ignalina NPP (Lithuania) has alleviated the need for use of E-CAP on spent fuel casks, saving hundreds of hours of effort and decreasing radiation exposure to departmental staff members while improving overall security.

Expected Outcome #3 from the 2018–2019 Biennium

Improved and expanded techniques, tools and procedures for containment verification.

Supporting R&D Need: T.5.R10

Key Outputs	Status	Comments
Report on the effectiveness of visual inspections of casks in cases where continuity of knowledge (CoK) is lost.	On hold	Consideration is being given to the future of a MSSP task proposal in 2020–2021. One possibility may be technology to confirm that a cask is empty or partially full for casks that cannot be opened during IIV/RII while in the Decon pit of a NPP.

Expected Outcome #4 from the 2018–2019 Biennium

Based on research and development results, implemented new and novel technologies that can be applied for secure sealing and containment verification systems.

Supporting R&D Need: T.5.R10

Key Outputs	Status	Comments
Solutions developed for: <ul style="list-style-type: none"> Tampering Indicating Covers (TIC1). Tampering Indications of Cables (TIC2). Tamper Indication of Cabinets (TIC3). 	Key output achieved; work continues	The IAEA has designed and constructed: <ul style="list-style-type: none"> Sealable pouch for storage and transport of samples. Mailboxes that log the time, protecting facility operator declarations against repudiation. Tamper indicating covers for large or old shapes of equipment.

Expected Outcome #5 from the 2018–2019 Biennium

Expanded and improved capabilities to identify and mitigate the vulnerabilities of safeguards equipment and data derived from equipment.

Supporting R&D Need: T.1.R9

Key Outputs	Status	Comments
Annual vulnerability assessment and review reports.	Key output achieved; work continues	A 3 rd party VA was performed on the LCCT's laser head by an external contractor. More systematic VAs may be contracted or a VR performed in-house for specific issues. The IAEA will perform outreach (either through direct contract or via MSSPs) to security experts, to perform peer review on these VRs.

Expected Outcome #6 from the 2018–2019 Biennium

Increased data security of safeguards equipment.

Supporting R&D Need: T.1.R9

Key Outputs

Status

Comments

Establishment of an assessment centre for safeguards instruments and their use based on attacking and defending security team.

Key output delayed; on hold until resources allocated.

Work is delayed, due to both space and resource constraints. Meanwhile, lack of an assessment centre impacts the IAEA's ability to find and mitigate vulnerabilities in SG equipment.

4. Expected outcomes, key outputs and tasks for the 2020–2021 biennium

In order to achieve overall objectives and meet R&D needs, tasks must be initiated, continued and/or finalized during the 2020–2021 biennium. The following expected outcomes serve as an outline for the next 2 years.

Expected outcome #1

Reduced inspector burden by demonstrating efficacy of LCCT.

Supporting R&D Need: T.5.R10

Key Outputs

Expected Completion Date

Pre-Installation joint-evaluation of completed SG-authorized system and its data with ABACC/ARN at non-critical facility in Argentina.

January 2020

An installation and field test of an LCCT at the dry storage silo array in Atucha-1, to demonstrate efficacy of wide area dual C/S for silos.

July 2020

Joint-evaluation system in Germany storage facility to determine effectiveness in decreasing effort.

February 2020

Broader authorization for other facilities.

July 2021

Plans for accomplishing the expected outcome

An increasing number of spent fuel storage areas will have radiation levels too high for inspectors to apply individual seals, as currently required under dual C/S. A perimeter approach to dual C/S is a more economical solution to the current dilemma and reduces inspector radiation dose.

The LCCT is a new approach to perimeter-wide dual C/S approach. However, the concept is extremely dependent on the particulars of the diversion scenario(s) and specific features of the facility. Therefore, extensive testing to ensure efficacy.

The IAEA has performed a vulnerability assessment of the LCCT. As the first of its kind (unattended laser system), the LCCT was granted provisional approval for drawing conclusions at Atucha-1 dry storage silos. This conservative approach temporarily authorizes a single nuclear facility for a limited duration allowing the IAEA to review efficacy before other facilities are considered or authorized.

The Argentine Support Programme has provided facility support in the past, and the IAEA would greatly benefit from further access in the future. The European Commission Support Programme has provided technology for the construction of the LCCT and development of review programmes, and the IAEA will seek to engage its future assistance with feasibility tests at German spent fuel storage sites.

Expected outcome #2

Maintain safeguards verification through seals by replacing the aging EOSS.

Supporting R&D Need: T.5.R10

Key Outputs

Expected Completion Date

Obtain approval for implementing field tests.	January 2020
Completed radiation tests on Active Universal Asymmetric Seal (AUAS). Completed environmental tests on AUAS.	May 2020
Commence vulnerability assessments.	June 2020
Initiate field tests at multiple locations.	July 2020
Analyse results from completed field tests and mitigate deficiencies.	July 2021
Authorize AUAS as a replacement for EOSS.	January 2021

Plans for accomplishing the expected outcome

The EOSS has obsolete components and protocols placing it at the end of its sustainable life, and the IAEA has committed to replacement of all EOSS seals in 2021. The IAEA is considering the best designs for an active asymmetric optical seal. Asymmetric cryptography removes the risks and inconvenience of forcing each inspector to carry a crypto-token into a nuclear facility. Key requirements also include that the new seal must have an extended battery life (>5-years). Prototypes are being evaluated under laboratory test conditions, but extensive field trials will be needed before a replacement can be authorized for safeguards use.

In development of the best solution meeting IAEA needs, the European Commission Support Programme developed a prototype asymmetric optical seal called the Active Optical Loop Seal (AOLS). The IAEA contracted fabrication of the prototype Laboratory and that testing proved promising. Unfortunately, components on one prototype AOLS failed the radiation tests required for safeguards authorization. Redesign of the affected system is under consideration. Meanwhile, other environmental and radiation tests will continue on the unaffected parts of the system.

However, the EOSS replacement is obligatory so the IAEA has mitigated risks with an alternative design, called the Active Universal Asymmetric Seal (AUAS). This design was completed in-house and incorporates lessons learned from the AOLS. The architecture for both hardware and software are completely non-proprietary and implemented using an ultra-low power consumption philosophy of a 'system-on-chip' microcontroller.

Project plans for 2020–2021 include:

- Complete testing and begin field trials of the AUAS.
- Authorize a new generation of asymmetric active seal (AOLS or AUAS), replacing the near-obsolete EOSS in totality by end of 2021.

The IAEA will seek further support from the MSSPs, to facilitate field-testing and VA/VR of one or more asymmetric active sealing systems documenting due diligence as part of the authorization process.

Expected outcome #3

Effective, passive, verifiable-in-the-field seals that replace E-CAP (metal seals).

Supporting R&D Need: T.5.R10

Key Outputs

Expected Completion Date

Finalized seal designs.	February 2020
Assessments of the designs, security features and vulnerabilities of the seals.	May 2020
Initial results from field-testing of the selected designs.	June 2020
Selection of the final seal design.	January 2021
Submission of the final seal design for Department authorization.	May 2021

Plans for accomplishing the expected outcome

The E-CAP has reached the end of its practical lifecycle. Limitations, such as verification that can only be performed at IAEA headquarters in Vienna, cause schedule delays and timeliness issues. The E-CAP requires a seal wire to be crimped or tied, which complicates attachment and verification.

A new passive seal is intended to decrease inspector involvement in tedious verification activities (such as associated with spent fuel casks), improve security (by alleviating a number of inconclusive scenarios), decrease overall effort (without drastically increasing life-cycle costs) and significantly improve timeliness of drawing a conclusion.

MSSPs will be requested to support the development of a new passive seal with technical prototypes and the assessment and testing of potential E-CAP replacements. Therefore, request for support will be targeted to MSSPs that have expertise in the material sciences in conjunction with containment technology.

In order to realize a passive seal that can be verified in-the-field, a new reader is required. Under MSSP task EC E 2008 (Identification, Development, Testing and Vulnerability Assessment of Sealing Technologies for International Safeguards), the EC-JRC is working to develop a prototype reader that can verify both the new passive seal and Cobra Seals.

Overall, project plans include designing, assessing, testing and authorizing an E-CAP replacement. The IAEA plans to conduct assessments and testing in-house, supported by MSSPs.

Expected outcome #4

Decreased efforts during DIVs by more efficient continuity of knowledge (CoK) for destructive analysis (DA) samples. This approach allows for CoK inside hot cells but verifiable from outside the hot cell. The system supports objectives required for pyro-processing facilities in the ROK and elsewhere.

Supporting R&D Need: T.5.R10

Key Outputs

Expected Completion Date

A finalized design of the Hot Cell Enclosure for Samples (HCES).	May 2020
Results from continued field tests to prove efficacy of the HCES.	June 2020
Iterated designs and prototypes of HCESs as required.	July 2020
A completed vulnerability review of the HCES.	January 2021
Initiation of the Safeguards Authorization process for the new HCES.	May 2021

Plans for accomplishing the expected outcome

There are a number of safeguards activities that require DA samples to be taken and stored inside hot cells. For example, pyro-processing will require hundreds of DA samples during operation but cannot be immediately extracted from the hot cell.

Development of a tamper-proof enclosure, to hold and store DA samples within a hot cell, with the ability to verify the integrity of the enclosure from outside the hot cell, significantly reduces inspection effort. Without such an enclosure, inspectors would have to oversee a prolonged period from sampling followed by the removal of the individual sample from the hot cell through air locks. This is all but impractical.

Internally, the IAEA has designed, developed and constructed a number of prototype enclosures for testing. The Hot Cell Enclosure for Samples (HCES) is designed to be extensively used in joint-use arrangements. This requires complete integration with facility operator procedures, safety considerations and anti-tampering measures. Therefore, close cooperation of requirements and testing must be arranged with multiple stakeholders. For example, the HCES must be capable of being opened/closed by a facility operator using mechanical manipulators. Prototypes must therefore go through extensive testing in functional or mock-up hot cells. The Republic of Korea Support Programme has provided the IAEA with facility access and technical support for testing. Plans are underway to initiate hot cell tests in Daejeon's Pyro-processing Research Centre.

The United States Support Programme will be requested to provide technical expertise, use of facilities at the Idaho National Laboratory and IAEA travel, to ensure the HCES operates sufficiently as a tamper indication enclosure in a range of hot cells configurations.

Expected outcome #5	
Mitigated safeguards vulnerabilities by exploration of alternative passive sealing technologies that enhance or replace current passive seals.	
Supporting R&D Need: T.5.R10	
Key Outputs	Expected Completion Date
Assessment from reports and/or data on practical technologies emerging on the commercial market on high security Radio-Frequency Identification (RFIDs).	December 2021

Plans for accomplishing the expected outcome

RFIDs are envisioned to be eventually integrated into future seal designs. The objectives would be to improve tamper indication, decrease efforts in seal verification, while improving security through the RFID's contribution of a second strong authentication measure. This project focuses on identifying and potentially integrating the latest secure RFIDs that are emerging on the commercial market. The key to successful implementation will be an integration that balances three vectors:

- Improvements in tamper protection
- Economical costs
- Decreasing verification effort

MSSPs that have experience with integrating RFID technologies in high-security applications will be sought to provide expert support and other resources.

Expected outcome #6	
Improve the security of data collected on the computers of mobile safeguards equipment by developing and improving cryptographic techniques in coordination with Departmental security objectives.	
Supporting R&D Need: T.5.R10	
Key Outputs	Expected Completion Date
A research paper on the latest relevant cryptographic techniques.	May 2020
Consult with Member State experts in cryptographic technologies.	December 2020
Expert consultations and sessions in cryptography to determine results and testing protocols (in other words, discuss testing researched work).	January 2021
Results from cryptography technique tests on safeguards equipment (in other words, assessing tests agreed in the Expert consultations).	June 2021
Implementation of cryptography techniques based upon the conclusions from the tests.	December 2021

Plans for accomplishing the expected outcome

The IAEA will seek MSSPs with appropriate expertise to support in developing and implementing cryptographic technologies in environments requiring computer-controlled portable equipment. This support will include arranging meetings with experts in the respective States. Internally, the IAEA

will identify, test and implement cryptographic techniques that protect data collected and stored on mobile computing devices associated with safeguards equipment.

5. Attachments

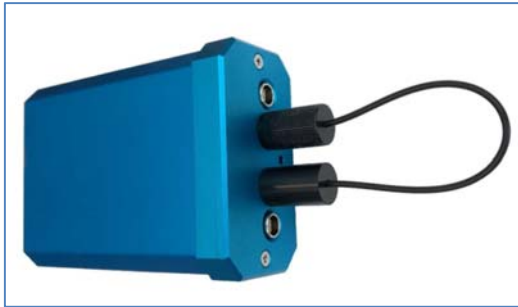

Figure 52: Active Universal Asymmetric Seal

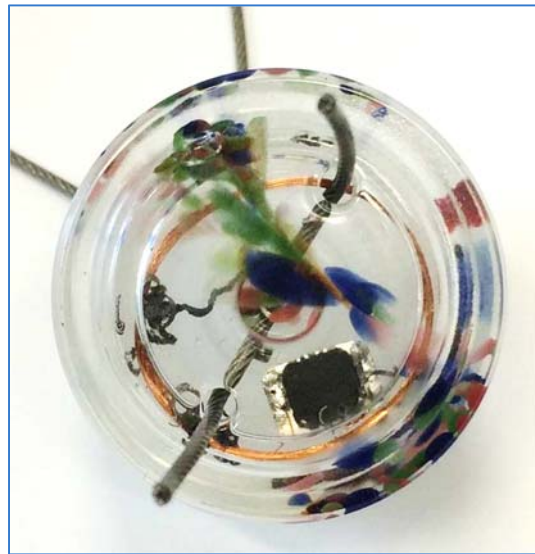

Figure 53: Concept of New Passive Seal with high-security RFID

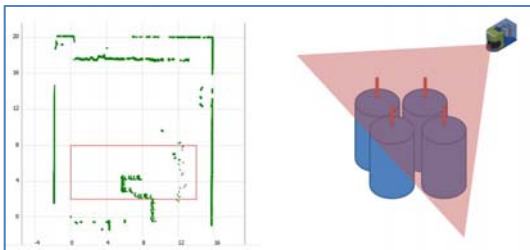

Figure 54: Laser Curtain for Containment (LCCT)

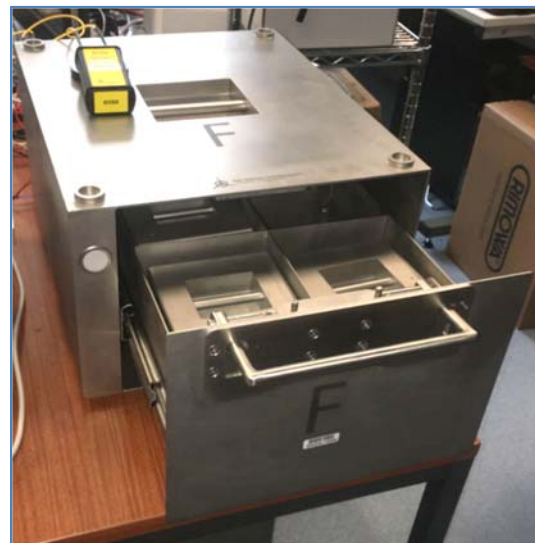

Figure 55: Hot Cell Enclosure for Samples (HCES)

SGTS-003: Surveillance Techniques

Project Manager: Tony LAVIETES

1. Overview

This chapter describes the plans for developing and implementing comprehensive surveillance technologies, software tools and equipment for the 2020–2021 biennium.

Project objective

The overall objective is to develop and implement comprehensive surveillance equipment (required for new and existing safeguards applications) and to replace legacy surveillance equipment and instruments used for routine safeguards inspection activities.

Foreseen challenges

The primary anticipated challenges that the project could face in the near future include:

- Addressing the difficult task of a significantly increasing volume of surveillance data, requiring the development of advanced data review and analysis capabilities to facilitate a comprehensive and efficient review process for Next Generation Surveillance System (NGSS) data.
- Mitigating the critical problem of hazardous radiation environments on the lifetime of surveillance equipment, for enhanced reliability.
- Developing alternative surveillance power and data transmission capabilities to mitigate the infrastructure problems experienced in remote or off-the-grid implementations.
- Developing solutions that address the critical need for high-reliability, extreme environment battery technologies, for extended operational lifetime and minimized scheduled maintenance activity.

Top project priorities in 2020–2021

- Complete the initial deployment of the Next Generation Surveillance Review (NGSR) software; a modular and highly efficient surveillance review software tool.
- Implement relevant NGSR functional and user interface revisions, based on operational experience and requested enhancements.
- Initiate the development of advanced surveillance data analysis algorithms, using machine learning and deep learning techniques where appropriate, to provide rapid video review capabilities for large datasets.
- Identify and evaluate safeguards-relevant applications of new and/or emerging technologies, to broaden the capabilities of surveillance by incorporating alternate technologies (for example, Radio Frequency (RF), ultrasonics, acoustics, sonar and hyperspectral imaging).
- Initiate the development of user requirements for the follow-on surveillance technology intended to replace NGSS in the future.

2. Strategy framework linkages

IAEA's Programme and Budget project linkage

The plan and MSSP tasks detailed in this chapter are followed-up and/or coordinated by Agency staff and are aligned with the objectives of the Agency's projects #4.1.6.002 Unattended safeguards instrumentation and #4.3.2.001 Development of equipment components and stand-alone instruments in the *Agency's Programme and Budget 2020–2021*.

Safeguards Research & Development Plan linkage

Priority Objective		R&D Needs	
T.1	Strengthen instrumentation capabilities for verification	T.1.R2	Develop the Next Generation Surveillance Review software (NGSR).
		T.1.R3	Assess existing techniques to detect misuse of reprocessing plants (real time detection of Pu separation).
		T.1.R5	Develop improved tools and techniques to enable real time flow measurements of nuclear material, including UF ₆ at enrichment plants and conversion plants, and Pu at reprocessing plants.
		T.1.R9	Strengthen intrusiveness and vulnerability analyses on current and future use of unattended systems, particularly to address any new threats resulting from technology advancements.
T.5	Identify and exploit innovations	T.5.R4	Define requirements for SG surveillance technology beyond the next generation surveillance system (NGSS).

Collaborating D&IS projects

- SGCP-101: Training
- SGIS-003: Safeguards Information Systems and System Usability
- SGTS-002: Techniques and Instruments for Sealing and Containment Verification
- SGTS-008: Instrumentation Technology Foresight
- SGTS-011: Unattended Measurement Techniques
- SGTS-014: Remote Monitoring and Data Processing Systems

3. Progress on expected outcomes, key outputs and tasks from the previous biennium

Expected Outcome #1 from the 2018–2019 Biennium		
Enhanced ability to deploy equipment at facilities to meet safeguards requirements through development of highly effective and cost efficient optical surveillance measures with improved security features.		
Supporting R&D Need: T.1.R2		
Key Outputs	Status	Comments
Working prototype for benchmark testing developed in collaboration with Project SGTS-014, (Phase 1 development of new surveillance review software).	Key output achieved; work continues	The Next Generation Surveillance Review (NGSR) software tool development is continuing, and a beta test user group has been established to concurrently provide user feedback.
External battery power unit for extended XCAM operation in stand-alone, unpowered applications.	Key output achieved; work completed	The Extended Power XCAM (XPCAM) system has been developed and successfully installed in a few select locations in the field.
Results of assessment of shape recognition module.	Key output achieved; work continues	Encouraging preliminary results of surrogate object identification and labelling using prototype analysis algorithms have been provided.
Assessment results of the VideoZoom module.	Key output achieved; work continues	The latest version of VideoZoom has been reviewed. Developments continue, with the intent to integrate with other video analysis tools and the Inspector Review and Analysis Platform (IRAP).

Integration and prototype testing of the surveillance review software tool.	Key output achieved; work continues	NGSR integration into the new IRAP platform is at an advanced stage; work is in progress on full implementation.
---	-------------------------------------	--

Expected Outcome #2 from the 2018–2019 Biennium

Improved tools and techniques developed to facilitate the detection of undeclared activities at nuclear facilities.

Supporting R&D Need: T.1.R3

Key Outputs	Status	Comments
Results of evaluation through laboratory and field testing of the 3DLC laser scanner-based precision mapping tool for routine containment verification tasks.	Key output achieved; work continues	Several field exercises in support of containment and surveillance activities have been executed, as part of an ongoing concept development process.

Expected Outcome #3 from the 2018–2019 Biennium

Improved tools and techniques developed to enable real-time monitoring and flow measurements of nuclear material (for example, UF₆ cylinders and spent fuel casks) at nuclear facilities.

Supporting R&D Need: T.1.R5

Key Outputs	Status	Comments
Results of assessment of the applicability of the L2IS Laser Item Identification System, in new enrichment plants and spent fuel storage facilities (In collaboration with project SGTS-002).	Key output achieved; work continues	Continuing activities in the development of a multi-scan 2D laser system are being pursued.

Expected Outcome #4 from the 2018–2019 Biennium

Improved response to new threats resulting from technology advancements through advanced intrusiveness and vulnerability analysis on current and future use of unattended systems.

Supporting R&D Need: T.1.R9

Key Outputs	Status	Comments
Results of the evaluation and vulnerability assessment of the DCM-A1, next generation analogue camera recording module.	Delayed; nearing completion	Vulnerability assessment of the tamper-indicating capability is nearing completion.

4. Expected outcomes, key outputs and tasks for the 2020–2021 biennium

In order to achieve overall objectives and meet R&D needs, tasks must be initiated, continued and/or finalized during the 2020–2021 biennium. The following expected outcomes serve as an outline for the next 2 years.

Expected outcome #1

Enhanced ability to deploy equipment at facilities, to meet safeguards requirements through development of highly effective and cost efficient optical surveillance measures with improved security features.

Supporting R&D Needs: T.1.R2 and T.5.R4

Key Outputs	Expected Completion Date
Working Next Generation Surveillance Review (NGSR) prototype for benchmark testing developed in collaboration with Project SGTS-014 (Assessment of Phase 1 NGSR surveillance review software).	December 2020

Initial performance assessment report of the prototype shape recognition module using relevant datasets.	March 2020
Assessment results report for the VideoZoom module.	September 2020
Create, refine and document the initial user requirements to guide the development of surveillance technologies intended to succeed NGSS.	December 2021

Plans for accomplishing the expected outcome

The Department expects to distribute the Next Generation Surveillance Review (NGSR) software tool for performance evaluation, as well as comparing it against the existing tool (GARS), to assess new and enhanced capabilities. This activity is intended to include relevant facility personnel and host country safeguards organizations involved in Joint-Use implementations. MSSPs will be requested to facilitate arrangements and provide resources to assist in the evaluation.

MSSP collaboration will be essential when performing a detailed assessment of advanced surveillance data analysis algorithms using relevant, representative datasets to determine performance, efficiency and effectiveness.

Task EC E 1992 (Research, Development and Evaluation of a Surveillance Review Software based on Automatic Image Summaries (VideoZoom)) provides access to an innovative surveillance review method based on 'Automatic Image Summaries,' which was developed by the Joint Research Centre Ispra (JRC). In 2015, an updated version of JRC's 'VideoZoom' tool was made available to the IAEA, allowing assessment of the software by using existing NGSS surveillance data. Further enhanced versions were provided annually, extending the capabilities, increasing performance and optimizing the design. Work is continuing, to evaluate the performance and interoperability of the VideoZoom tool with relevant datasets and assess its potential for integration into IRAP as a plug-in module. Completion of the assessment, and a decision as to whether VideoZoom technology shall be implemented under 'In-house Task #1' and Project SGTS-014, is planned for September 2020.

The Department intends to develop the surveillance system concepts and requirements to be considered for the successor to NGSS to leverage NGSS lessons learned and surveillance-relevant emerging technologies in collaboration with MSSPs and project SGIS-003: Safeguards Information Systems and System Usability. The IAEA will propose and lead a multi-MSSP task to fully engage all stakeholders in the development of user requirements for the follow-on surveillance technologies that will supersede NGSS. This is intended to complement work already in progress.

Research on and evaluations of emerging 3D camera technologies are carried out under Task EC E 1636 (Engineering Support for 3D Camera Development). Recent developments in 3D cameras for the automotive market (autonomous car navigation) are placing advanced technology within the reach of potential implementation within safeguards equipment. Currently, evaluated technologies include Velodyne sensors and Microelectromechanical Systems (MEMS) LiDAR devices. Benchmark performance reports about the technologies are being produced at each deployment opportunity. When compared to the currently-used two-dimensional (2D) optical surveillance, active 3D cameras would strengthen the surveillance data authenticity and eliminate the need for ambient lighting. The work accomplished under this task provides essential input for the user requirements of safeguards surveillance equipment beyond the NGSS.

MSSP task GER E 1982 (NGSS Product Lifecycle Support) provides lifecycle support for NGSS, to ensure sustainability of relevant technology. Activities performed under this task include changes and updates to address new needs from safeguards inspectors; enhancements to support changes in the IAEA's data security environment Public Key Infrastructure (PKI) and firmware updates to address issues identified during acceptance testing and field implementation.

A replacement Junior Professional Officer (Associate Surveillance Systems Engineer) will be requested from the German Support Programme, to test and analyse the radiation effects on solid State storage media (for example, SD cards), which are considered critical components of NGSS instruments.

MSSP task proposal 19/TUS-004 (Radiation Effects and Mitigation Techniques—currently pending MSSP decisions—is focused on characterizing system-level radiation effects on NGSS instrumentation. Activities are to include modelling and analysis of radiation effects on NGSS system components; testing of relevant components in representative radiation environments and assisting in the development of mitigating actions to address any identified vulnerabilities. It is expected that extensive literature searches and technical exchanges with recognized experts in the field will be pursued.

Expected outcome #2

Improved ability to detect undeclared activities at nuclear facilities with tools and techniques.
Supporting R&D Need: T.1.R3

Key Outputs

Expected Completion Date

Evaluation of advanced 3DLR and LiDAR technologies in relevant facilities in support of ongoing safeguards activities. December 2021

Evaluation of the potential of 3DLR and advanced LiDAR technologies to support unique implementations of Dual Containment and Surveillance (C/S). December 2021

Plans for accomplishing the expected outcome

Under Task EC E 1993 (Scientific and Technical Support for 3D Laser Range Finder (3DLR)), the JRC currently provides scientific and technical support for the 3DLR laser scanner-based Design Information Verification (DIV) tool. 3DLR is successfully used in supporting safeguards at large and complex facilities, such as reprocessing plants and underground geological repositories for spent nuclear fuels. Work accomplished under this task is also aimed at enhancing the 3DLR's applicability to a broader range of containment verification needs.

Going forwards, the Department seeks a continuing programme of field testing at relevant facilities, evaluating results against defined safeguards criteria. In addition, the applicability of 3DLR and advanced LiDAR technologies to satisfy the Dual C/S requirements requires assessment. MSSPs will be requested to facilitate field testing and provide resources for testing, evaluation and assessment activities.

Expected outcome #3

Improved real-time monitoring and flow measurement capabilities of nuclear material at nuclear facilities (for example, UF₆ cylinders and spent fuel casks) by developing tools and techniques.

Supporting R&D Need: T.1.R5

Key Outputs

Expected Completion Date

A developed ultra-high frequency (UHF) Passive Tag monitoring and tracking system with advanced capabilities for persistent, real-time, non-optical surveillance of items of interest. July 2021

A developed conceptual framework for an Ultra-Wideband (UWB) Passive Tag monitoring and tracking system with advanced capabilities for persistent, real-time, non-optical surveillance of items of interest. December 2021

Plans for accomplishing the expected outcome

Advanced UHF passive tags are being assessed with respect to providing real-time, persistent monitoring and tracking of items of interest. The use of this technology precludes the need for line-of-sight, allowing for position-insensitive tag interrogation and simplified tag attachment. As a complement to traditional surveillance, individual item presence, location and movement can be remotely monitored, which eliminates manual inspection and potential exposure to hazardous environments. Initial applications are at nuclear power plants, nuclear material bulk handling facilities and storage facilities; with a limited facility implementation by July 2021. MSSPs will be requested to facilitate field testing and provide resources for testing, evaluation and assessment activities.

Expected outcome #4

Improved response to new threats resulting from technology advancements, through advanced intrusiveness and vulnerability analysis on current and future use of unattended systems.

Supporting R&D Need: T.1.R9

Key Outputs

Expected Completion Date

An evaluation and vulnerability assessment of the DCM-A1, next generation analogue camera recording module, with respect to tamper indication efficiency and effectiveness. June 2020

Plans for accomplishing the expected outcome

Under MSSP task GER E 1994 (Analogue Camera Support for the NGSS DCM-C5 Surveillance Core Component) (completed in 2016), an analogue input for the NGSS camera, supporting, inter alia, facility operator-owned cameras, was developed. The development included the implementation of sophisticated active, electronic protection (using Spread Spectrum Time Domain Reflectometry, SSTDR) of the video cable used to connect analogue cameras. Prototypes, which were received in 2015, have been implemented in the latest NGSS camera design (DCM-A1 module) and a vulnerability assessment is in progress under Task USA E 2354 (Vulnerability Assessment of the DCM-A1 SSTDR diagnostics feature (LiveWire)). This task also provides input to developments carried out under projects SGTS-002 and SGTS-011 potentially benefitting from the implementation of SSTDR technology.

5. In-house development tasks

The table below lists internal development activities that will continue, but which will benefit from external contributions to the project. It gives an understanding of how external stakeholders can:

- Complement existing work
- Initiate activities in under-served areas of need
- Avoid duplicate activities

Expected outcome	Task #	Task Title (Agency's cross reference)	Description	Expected Completion Date
1	1	Develop and implement infrastructure for the Department's surveillance laboratories (4.3.3.001 – 2018.04)	Develop and implement infrastructure, such as hardware and software tools, for the Department's surveillance laboratories to increase efficiencies in sustaining surveillance equipment testing and implementation.	Ongoing
	2	Monitor and evaluate progress made in surveillance technology research (4.3.3.001 – 2018.04)	Monitor the progress made in surveillance technology research and evaluate commercially available alternatives to traditional optical surveillance systems with a focus on laser-, RF-, sonar-, radar- and ultrasonic-based technologies.	Ongoing
	3	XMOS (NGSS) large scale multi-camera server development (4.3.3.001 – 2018.04)	XMOS is a surveillance server designed to replace the old DMOS multi-camera system server when upgrading to NGSS technology. XMOS is based on standard NGSS components augmented with an industrial touch screen panel, PC and server software developed by SGTS in-house resources.	June 2020
	4	Vulnerability review of SSTDR technology implemented in analogue camera NGSS module phase 1 (4.3.3.001 – 2018.04)	The SSTDR implemented in the analogue camera NGSS module (DCM-A1) needs to be assessed for potential vulnerabilities. Phase 1 of the assessment is a vulnerability review, which is carried out with in-house resources. Phase 2 will be a more comprehensive vulnerability assessment, for which a USSP SP-1 is in progress.	Phase 2 to be completed in June 2020

	5	Develop wireless communication interface for the NGSS camera (4.3.3.001 – 2018.04)	Develop a fully integrated, secure wireless communication module for the NGSS camera to eliminate the need for data cables in certain SG applications.	December 2020
	6	Final testing of the Next Generation Surveillance Review Software development (4.3.3.001 – 2018.04)	Funded by regular budget and in cooperation with Euratom, a Next Generation Surveillance Review software is being developed. Final lab testing is in progress and initial field testing will be completed in the next phase.	Ongoing

6. Attachments

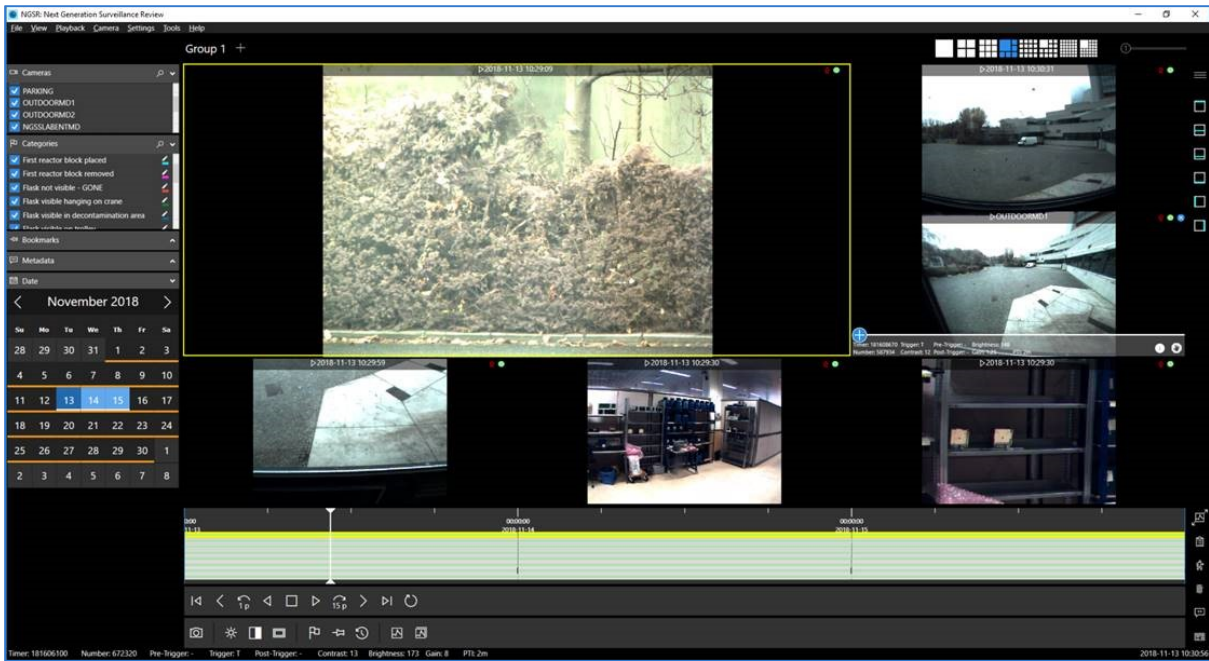

Figure 56: NGSR User Interface

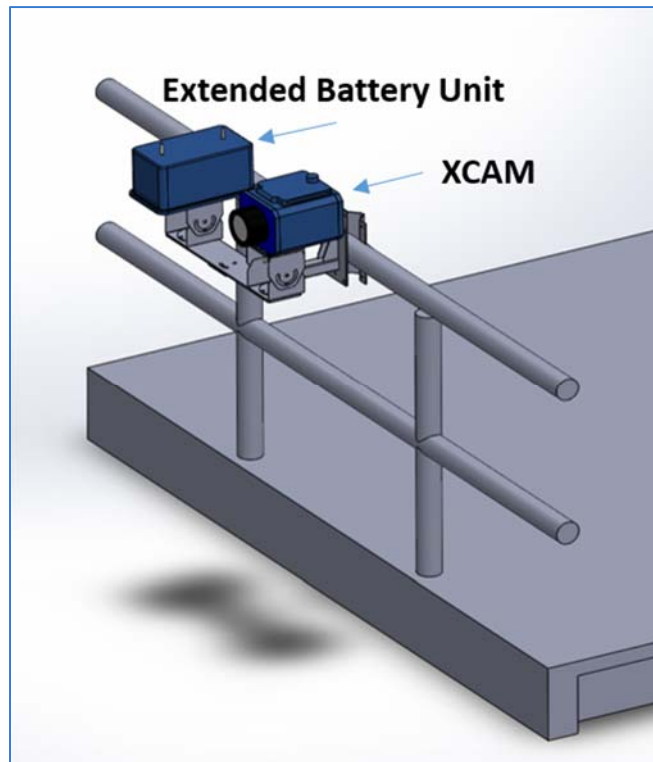

Figure 57: XPCAM Deployment Configuration

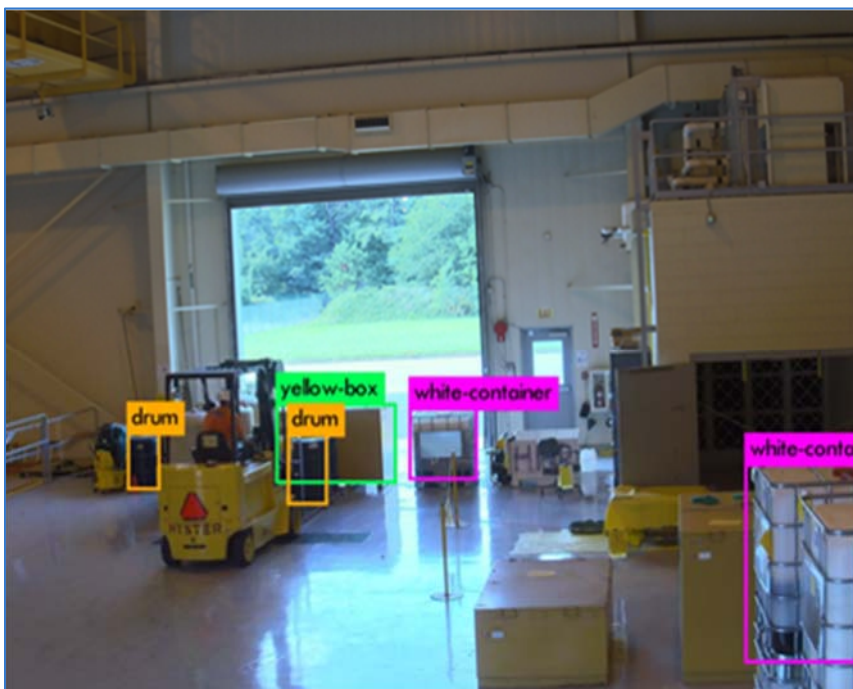

Figure 58: Basic Shape Recognition

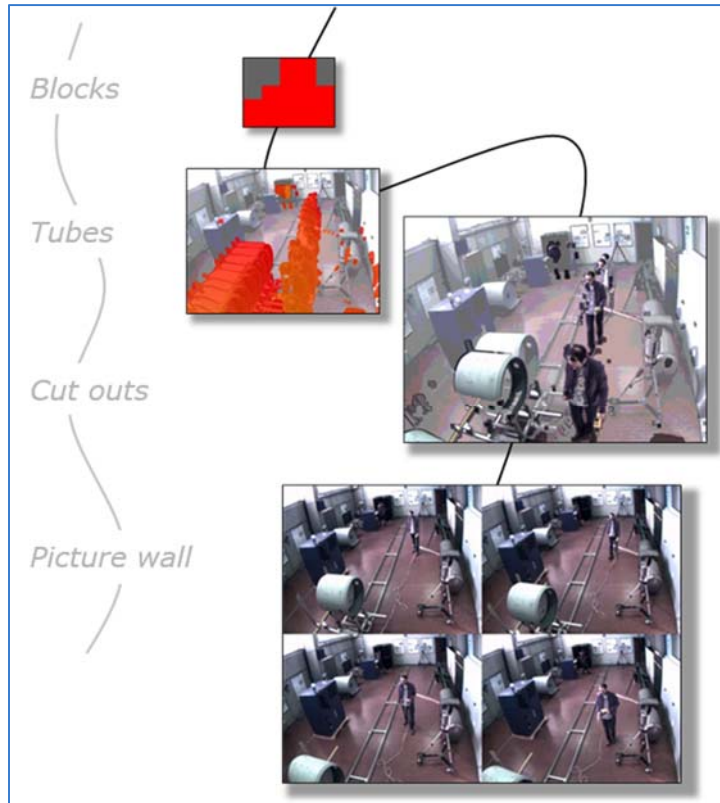

Figure 59: VideoZoom Scene Change Detection - Abstract Overview to Individual Detailed Images

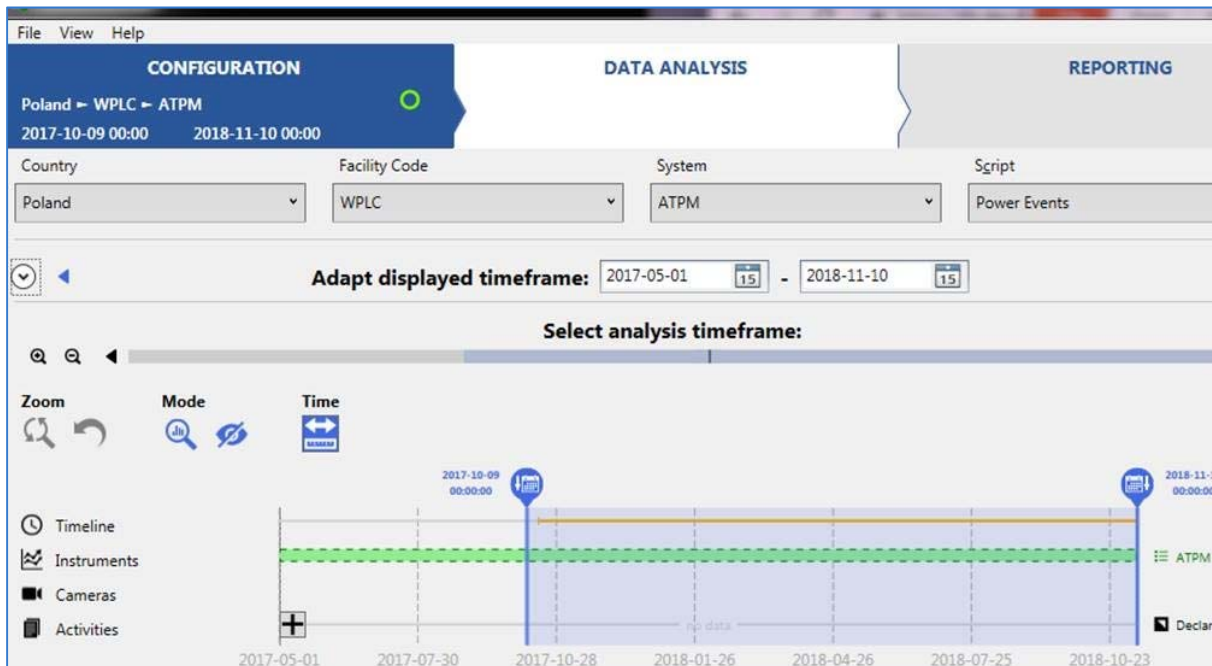

Figure 60: IRAP User Interface



Figure 61: Sample 3DLR Scan Image

SGTS-008: Instrumentation Technology Foresight

Project Manager: Dimitri FINKER

1. Overview

This chapter describes the plans for developing and implementing Instrumentation Technology Foresight during the 2020–2021 biennium.

Project objective

The overall objective is to: identify, evaluate, test, develop, authorize and deploy emerging technical advances from other scientific fields and optimize them for use in safeguards. The IAEA has recognized and articulated the need to take full advantage of relevant technical advances made outside the safeguards community, to strengthen IAEA verification activities in a manner that is less costly, less 'custom' wherever possible and more sustainable. For this reason, the IAEA has placed renewed emphasis on developing a robust in-house technology foresight capability.

The Technology Foresight pipeline underlying the innovation cycle consists of the following stages:

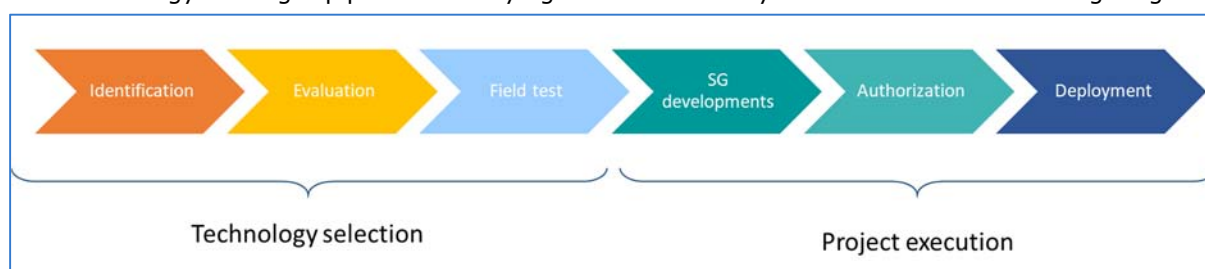

Figure 62: Technology Foresight innovation pipeline

Technologies are evaluated and prioritized at each step of the innovation cycle using the following criteria:

- Maturity (Does it work?)
- Usefulness (Does it solve a safeguards problem?)
- Applicability (Can be it adapted for safeguards verification?)
- Operational convenience (Will it be used by IAEA? Are there any competing, less cumbersome alternatives?)
- IAEA readiness (What are the current bottlenecks preventing its deployment?)

A thorough selection is made throughout the innovation pipeline: during the early stages (technology selection), many of the initial technologies are discarded or placed in stand-by, when the level of effort to adapt them at this point in time is not proportionate to the value brought to Safeguard verification. This drastic selection ensures that IAEA resources are directed for the execution of the most promising projects leading to successfully authorized instruments. In the last five years, 390 technologies were identified by the Technology Foresight programme, with only 5% being retained for project execution, leading to the authorization of 17 new instruments and 9 additional authorizations being underway.

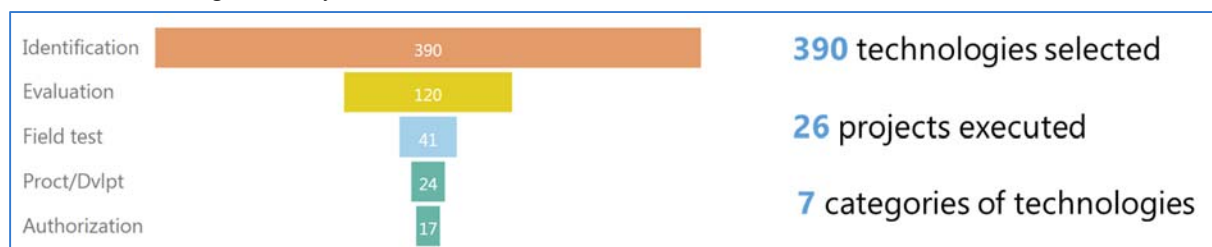

Figure 63: Technologies in the Technology Foresight innovation pipeline

One effective mechanism to significantly accelerate this selection through the pipeline has been to organize Technology Challenges, using a crowdsourcing approach to expand our outreach. Furthermore, the creation of searchable Technology Foresight Database ensures that we capitalize the results of the technology selection, enabling the IAEA to efficiently re-evaluate a technology that had been previously discarded, when technological or operational factors have evolved.

Foreseen challenges

The ability to maintain a sustainable innovation cycle across several concurrent projects is key to build momentum and regularly deliver new systems to the Department. The challenge is to retain a continuous outreach effort while simultaneously carrying out several development and support activities for a growing portfolio of projects.

An additional challenge is to accelerate the transition of new products developed from Technology Foresight into routine adoption for field verification.

Top project priorities in 2020–2021

- Gradually supplement and replace use of the Improved Cerenkov Viewing Device (ICVD) by the Next Generation Cerenkov Viewing Device (XCVD).
- Finalize the development of deployable Robotized Cerenkov Viewing Device (RCVD) carried inside an Unmanned Surface Vehicle (USV).
- Authorize and expand the use of Chemical Identification devices.
- Expand the use of the Multi Components Inspector Kit (MCIK).
- Evaluate the application of 3D mapping combined with radiation imaging.
- Conduct and expand the outreach of Technology Challenges through crowdsourcing platforms.

2. Strategy framework linkage

IAEA's Programme and Budget project linkage

The plan and MSSP tasks detailed in this chapter are followed-up and/or coordinated by Agency staff and are aligned with the objectives of the Agency's project #4.3.2.002 Development of instrumentation systems and methodology in the *Agency's Programme and Budget 2020–2021*.

Safeguards Research & Development Plan linkage

Priority Objective	R&D Needs
T.5 Identify and exploit innovations	T.5.R1 Identify, evaluate and test promising applications of robotics and machine learning/artificial intelligence to improve the effectiveness and efficiency of safeguards.
	T.5.R2 Identify areas in which technology challenges (for example, expert crowdsourcing) could be an asset for developing the Department's technologies and methodologies.

Collaborating D&IS projects

- SGCP-004: Strategic Planning and Partnerships
- SGIS-003: Safeguards Information Systems and Usability

3. Progress on expected outcomes, key outputs and tasks from the previous biennium

Expected Outcome #1 from the 2018–2019 Biennium		
Developed and implemented technology foresight horizon scanning process for external, potentially-relevant research and development (R&D) fields. Supporting Priority Objective: T.5 and S.4		
Key Outputs	Status	Comments
Partnerships with new external stakeholders (those not yet involved with safeguards) to identify and evaluate R&D activities and technologies in the domains of non-destructive assay, containment, surveillance, and destructive analysis. (In collaboration with SGCP-004)	Key output achieved; work continues	Partnerships have been established with various external stakeholders through the technology challenges. Technology Foresight will continue to establish new partnerships with relevant parties.

Quarterly Preliminary Evaluation Report.	Technology	Key output achieved; work continues	Two Safeguards Technical Reports (STRs) were published (STR_388 <i>IAEA Robotics Challenge</i> and STR_387 <i>Technology Demonstration Workshop on Gamma Imaging</i>). Update on recent Technology Foresight accomplishments related to STRs were sent to all MSSPs in November 2019.
--	------------	-------------------------------------	--

Expected Outcome #2 from the 2018–2019 Biennium

Technologies identified and solutions implemented for gaps identified in technologies currently in use for safeguards and laboratory activities.

Supporting Priority Objective: T.1 and T.5

Supporting R&D Needs: T.5.R1 and T.5.R2

Key Outputs	Status	Comments
Evaluated, customized and authorized commercial in-situ analysis capabilities.	Delayed; nearing completion	Completion delayed due to requirements for additional safety certifications.
Deployment, after authorization, of two gamma imaging systems: one portable system, one mobile system.	Key output achieved; work completed	Focus on the portable high resolution large CZT system. Project transferred for authorization to Non-Destructive Assay Services (NDAS).
Full replacement of the former Complementary Access Kits by the new Multicomponent Inspector Kit, including IRIS software (Instruments Records Integration for Safeguards) as a means of structuring and streamlining the use of field instrumentation data.	Key output achieved; work continues	Full replacement achieved. Continuing to expand usage.
Development and authorization of the next generation of Cerenkov Viewing Device (XCVD).	Key output achieved; work completed	Gradual replacement of the ICVD with the XCVD is planned over the next 5 years.
Winners of robotics challenge selected for further development.	Key output achieved; work continues	Development work has commenced with the winner of the challenge.

4. Expected outcomes, key outputs and tasks for the 2020–2021 biennium

In order to achieve overall objectives and meet R&D needs, tasks must be initiated, continued and/or finalized during the 2020–2021 biennium. The following expected outcomes serve as an outline for the next 2 years.

Expected outcome #1

Improved and more efficient safeguards verification activities in the field through the use of innovative technologies.

Supporting Priority Objective: T.1 and T.5

Supporting R&D Needs: T.5.R1 and T.5.R2

Key Outputs	Expected Completion Date
Progressive roll-out of XCVD for spent fuel verification and transfer to SGTS-001: NDA Techniques	December 2021
Deployable Robotized Cerenkov Viewing Device (RCVD) enclosed inside an Unmanned Surface Vehicle (USV).	December 2021
Inclusion of Chemical Identification spectrometers in the MCIK and expansion of their application in the field.	June 2021

Integration of Instrument Record Integrator for Safeguards (IRIS) within MOSAIC tools, for streamlined reporting of field instrument data. December 2021

Completion of annual technology challenge for improving SG instrument data analysis. June 2021

Plans for accomplishing the expected outcome

Once a technology has been evaluated and shows potential to positively impact the implementation of safeguards, solutions are adapted and implemented in cooperation with the relevant departmental divisions.

The focus for 2020–2021 will be the development of the in-house build XCVD to an industrial and sustainable instrument while finalizing the field testing and development of USV robotic platforms, able to carry a robotized version of the XCVD.

Now that the MCIK has fully superseded the previous Complementary Access (CA) Kit, a series of new instruments for chemical identification in the field will be added and additional effort will be made to integrate IRIS software for reporting CA and DIV activities with MOSAIC modules in collaboration with project SGIS-003: Safeguards Information Systems and System Usability.

The following support from MSSPs for specific technical developments and reports will continue under MSSP tasks ARG A 1637, AUL A 1856, BEL A 1615, BRZ A 1601, CAN A 1622, EC A 1634, FIN A 1628, FRA A 1641, GER A 1633, HUN A 1597, JPN A 1798, NET A 1850, ROK A 1894, RSA A 2010, UK A 1599 and USA A 1616 (Support for Instrumentation Technology Foresight).

MSSPs can also support these initiatives by allowing the IAEA to conduct field tests in representative facilities, currently supported by MSSP tasks BEL A 2474, BRZ A 1601, CZ A 2451, EC A 2406, FIN A 2390, FRA A 2409 and RSA A 2459 (Field-testing of an Unmanned Surface Vehicle and neXt generation Cerenkov Viewing Device). MSSP task proposal 18/TND-001 (Field-testing of an Unmanned Surface Vehicle and neXt generation Cerenkov Viewing Device) seeks further support in this area.

Evaluation of gamma cameras with 3D functionalities will continue under MSSP task USA A 1616 (Support for Instrumentation Technology Foresight).

The IAEA will also continue to monitor and evaluate new areas for innovative solutions, to address unforeseen safeguards challenges that may arise during the biennium.

MSSPs can support these initiatives by:

- Facilitating and supporting the outreach efforts of the IAEA on specific topics, as identified;
- Supporting the early stages of adaption of solutions.
- Providing resources for related R&D efforts, to support the implementation of identified solutions.
- Supporting the testing and deployment of innovative technologies.

Expected outcome #2

Ability to develop, design and enhance safeguards solutions, faster and with fewer resources, by using external technologies from relevant R&D fields.

Supporting Priority Objective: T.5 and S.4

Key Outputs	Expected Completion Date
A list of new, external, non-traditional technology suppliers that have demonstrated their ability to develop specific solutions applicable to the domains of non-destructive assay, containment, surveillance and destructive analysis. (In collaboration with SGCP-004).	Ongoing
Searchable Technology Foresight Database summarizing the results of technology evaluation.	December 2021
Quarterly Technology Preliminary Evaluation Report.	Ongoing

Plans for accomplishing the expected outcome

Organizing Technology Challenges has proved to be an effective and innovative mechanism to achieve results. The latest challenge on Passive Gamma Emission Tomography (PGET) received 17 submitted solutions, which involved contributions from 14 countries. The Agency will seek to sustain

and expand this outreach effort with new challenge topics focusing on innovative processing techniques that could be applied to the analysis of safeguards instrument data.

MSSP tasks EC A 1634, FIN A 1628, FRA A 1641, GER A 1633, ROK A 1894, UK A 1599, USA A 1616 (Support for Instrumentation Technology Foresight) help to identify technology suppliers, advertise the Technology Challenges or directly support its organization by funding candidates, hosting the challenge or providing technical observers. The MSSP support has been an essential factor to the success of these initiatives.

Additionally, development of a database that gathers the outcomes of the horizon-scanning process, using a taxonomic categorization and summarizes the essential findings of the technology evaluation, will be completed by the end of 2021. This activity is under the supervision of a JPO, recruited under MSSP task USA A 2344 (Junior Professional Officer - Associate Instrumentation Engineer). This database will be continuously populated to document the outcome of TF activities and will serve as a knowledge repository of technological outreach for Safeguard instrumentation.

5. In-house development tasks

The table below lists internal development activities that will continue, but which will benefit from external contributions to the project. It gives an understanding of how external stakeholders can:

- Complement existing work
- Initiate activities in under-served areas of need
- Avoid duplicate activities

Expected outcome	Task #	Task (Agency's cross reference)	Title task	Description	Expected Completion Date
1	1	Continuous technology evaluation		1) Continue research and subsequent evaluation of technologies for potential safeguards applications. Store information in technology foresight database. 2) Issue regular "Technology Preliminary Evaluation Report."	Ongoing
2	2	XCVD		Phase out 10% of ICVDs and replace with XCVD.	December 2021
	3	Robotics Challenge		Develop and field test RCVD carried inside USV.	December 2021
	4	Chemical ID		Include chemical ID devices in the MCIK and expand use in the field.	June 2021
	5	IRIS		Integrate IRIS within MOSAIC tools.	December 2021
	6	Technology Challenge		Conduct annual technology challenge for improving SG instrument data analysis. Prospective topics include machine learning applied to improvement of spectral analysis, improvement of inertial positioning capabilities and Cerenkov image analysis.	June 2021

6. Attachments



Figure 64: Gamma imaging system undergoing IAEA testing prior to authorization

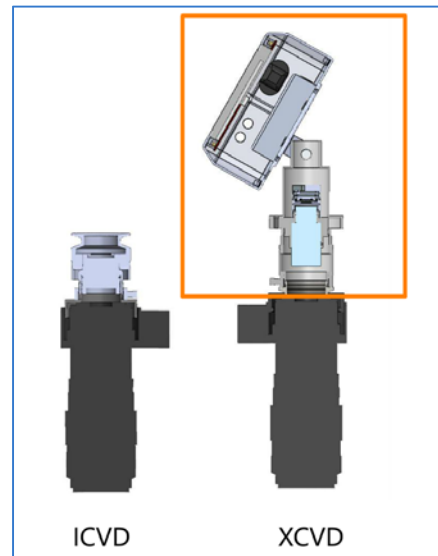

Figure 65: Comparison of the architecture of ICVD and XCVD

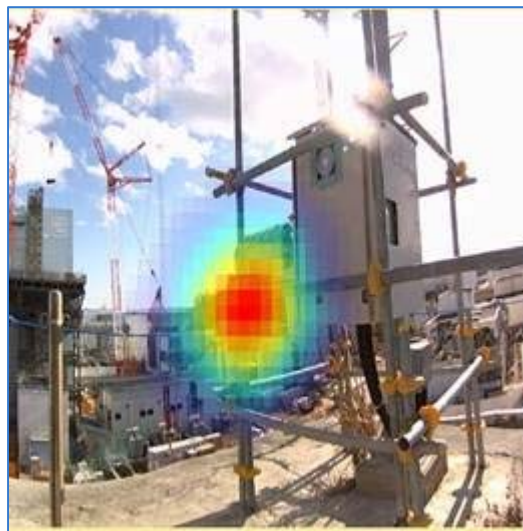

Figure 66: Output of the gamma imaging system in a field test

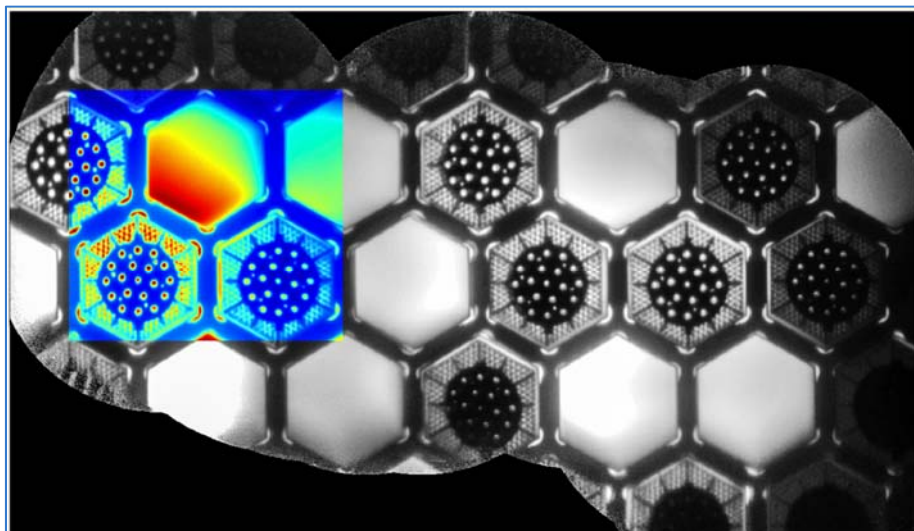

Figure 67: Processed image collected through the XCVD



Figure 68: XCVD used during field testing

SGTS-011: Unattended Measurements Techniques

Project Manager: Thierry POCHET

1. Overview

This chapter describes the plans for developing and implementing unattended measurement techniques during the 2020–2021 biennium.

Project objective

The overall objective is to provide optimized unattended measurement techniques that enhance present safeguards methods and capabilities for the monitoring of declared, and detection of undeclared, nuclear material and activities.

Foreseen challenges

- Labour and life-cycle costs associated with installation and maintenance.
- Increasing quantities of nuclear material under safeguards, at a greater number of facilities.

Top project priorities in 2020–2021

- Deployment of the Unattended Cylinder Verification System (UCVS) in an IAEA-safeguarded Gas Centrifuge Enrichment Plant (GCEP).
- Testing and procurement of the Unattended Data Logger (UDL1), the new generation data acquisition module to be used on most Unattended Monitoring Systems (UMS).
- Upgrading all UMSs with the UDL1, a new computer and a new full direct current (DC) power management system.
- Development of Time Domain Reflectometry (TDR) technology as an electronic tamper-indicating method, to be applied on cabling running from detectors to UMS cabinets.

2. Strategy framework linkages

IAEA's Programme and Budget project linkage

The plan and MSSP tasks detailed in this chapter are followed-up and/or coordinated by Agency staff and are aligned with the objectives of the Agency's projects #4.1.6.002 Unattended safeguards instrumentation and #4.3.2.002 Development of instrumentation systems and methodology in the *Agency's Programme and Budget 2020–2021*.

Safeguards Research & Development Plan linkage

Priority Objective	R&D Needs
T.1 Strengthen instrumentation capabilities for verification	T.1.R4 Improve tools and techniques to enable timely, potentially real time, detection of HEU production in LEU enrichment facilities.
	T.1.R5 Develop improved tools and techniques to enable real time flow measurements of nuclear material, including UF ₆ at enrichment facilities and conversion plants, and Pu at reprocessing facilities.
	T.1.R6 Develop safeguards equipment to establish and maintain knowledge of spent fuel in shielding/storage/transport containers at all points in their life cycle.

Collaborating D&IS projects

- SGIS-003: Safeguards Information Systems and System Usability
- SGOA-002: Safeguards System for JNFL MOX Fuel Fabrication Plant (J-MOX)
- SGOA-003: Fukushima Dai-ichi Safeguards
- SGOC-001: Chernobyl
- SGTS-001: NDA Techniques
- SGTS-014: Remote Monitoring and Data Processing Systems

3. Progress on expected outcomes, key outputs and tasks from the previous biennium

Expected Outcome #1 from the 2018–2019 Biennium		
<p>Developed tools and techniques to enable timely, potentially real-time, detection of HEU production in LEU enrichment facilities.</p> <p>Supporting R&D Need: T.1.R4</p>		
Key Outputs	Status	Comments
Results of monitoring the stability and accuracy of installed OLEM systems.	Key output achieved; work continues	Results thus far are encouraging, but require follow-on work.
Version 2 of the OLEM software.	Key output achieved; work continues	Beta versions of the V2 On-Line Enrichment Monitor (OLEM) suite of software have been delivered and are now in the testing phase.
Report on assessment of OLEM's reliability and associated recommendations.	Delayed; work in progress	A report is expected to be issued in 2020.
Expected Outcome #2 from the 2018–2019 Biennium		
<p>Improved tools and techniques to enable real-time flow measurements of nuclear material, including UF₆ at enrichment plants and Pu at reprocessing plants.</p> <p>Supporting R&D Need: T.1.R5</p>		
Key Outputs	Status	Comments
Prototype of an Unattended Cylinder Verification System (UCVS) installed in a Gas Centrifuge Enrichment Plant (GCEP) (Phase II).	Delayed; nearing completion	A UCVS prototype is undergoing testing at a UF ₆ storage facility in the United State of America before being sent to IAEA.
Report on the application and verification of joint-use data collected at enrichment plants.	Key output achieved; work completed	MSSP tasks JNT A 01879 FRA and EC (Evaluation of Data Collected From Operator Systems at Enrichment Plants) involves sharing load cell data at the George Besse II facility, was successfully completed.
Expected Outcome #3 from the 2018–2019 Biennium		
<p>Developed appropriate safeguards equipment to establish and maintain knowledge of spent fuel in shielding/storage/transport containers at all points in their life cycle.</p> <p>Supporting R&D Need: T.1.R6</p>		
Key Outputs	Status	Comments
Upgrade campaign of VIFM systems with new ADM2 (NGAM) data acquisition modules and updated power subsystems.	Key output achieved; work completed	The VXI Irradiated Fuel Monitor (VIFM) was successfully upgraded, including incorporation of the new ADM2 (Next-Generation Adam Module), with work completed by end-2018.
Completed upgrade of all other UMS systems.	Key output achieved; work completed	UMS systems were upgraded with new Standard COTS components, including new computers, UPSs, VPN devices, and new firmware and software versions.

Installed developed irradiated fuel counting system at a Pebble Bed reactor in China.	Key output achieved; work completed	The safeguards approach was developed and customized UMS systems were designed accordingly.
Installed new systems developed for safeguarding fuel at CANDU reactors.	Delayed; work in progress	Detector systems have been designed, but testing awaits fabrication of the prototypes.

Expected Outcome #4 from the 2018–2019 Biennium

Increased proportion of deployed unattended systems that are sustainable, standardized and modular with increased use of Commercial-Off-The-Shelf (COTS) products.

Supporting Priority Objective: T.1 and T.4

Key Outputs	Status	Comments
Evaluation, development, testing, and deployment of components and equipment that fulfil the requirements of being sustainable, standardized, and modular, with increased use of COTS products.	Key output achieved; work continues	Procurement of the UDL1 data acquisition module is in progress. Expected outcome #4 in the 2020–2021 plan addresses this continuing challenge, which includes upgrades to the MiniGRAND and Shift Register systems.

4. Expected outcomes, key outputs and tasks for the 2020–2021 biennium

In order to achieve overall objectives and meet R&D needs, tasks must be initiated, continued and/or finalized during the 2020–2021 biennium. The following expected outcomes serve as an outline for the next 2 years.

Expected outcome #1

Faster (and potentially real-time) detection of HEU production in LEU enrichment facilities through improved tools and techniques.

Supporting R&D Need: T.1.R4

Key Outputs	Expected Completion Date
Upgrades of On-Line Enrichment Monitor (OLEM) hardware and software.	December 2021
A report on overall OLEM performance enhancements.	July 2021

Plans for accomplishing the expected outcome

Within the context of MSSP task USA A 1913 (OLEM)), the stability and usability of OLEM will be extended through upgrades to hardware and software that are planned 2020–2021 and in collaboration with project SGIS-003: Safeguards Information Systems and System Usability. The hardware upgrade requires implementing and testing the newest version of the commercially-available micro-controller used in the OLEM collection nodes. The software upgrades consist of new versions (V2) of the full OLEM software suite that is used to collect, analyse and simulate data.

Performance enhancements are envisioned in terms of:

- Identifying header pipe material or coatings that eliminate or limit the growth of UF₆ deposits.
- Understanding the impact of light gasses on the measured gas pressure and enrichment.

Expected outcome #2

Ability to take real-time flow measurements of nuclear material, including UF₆ at enrichment facilities and conversion plants and Pu at reprocessing facilities, through improved tools and techniques.

Supporting R&D Need: T.1.R5

Key Outputs	Expected Completion Date
Installation of UCVS at an IAEA-safeguarded Gas Centrifuge Enrichment Plant (GCEP) for field testing.	December 2021

Plans for accomplishing the expected outcome

The IAEA has several State Level Approaches in place, specifically at the large scale GCEPs in Europe, that call for an extended approach to verification. This need leads to the potential use of UCVS in these 'candidate' or 'host' facilities.

MSSP task JNT A 1979 USA (Viability of an Unattended Cylinder Verification Station (UCVS) for Enrichment Plant Safeguards) will yield a functional prototype of the UCVS, which will require in-house modification to put it in a UMS-ready state. This will include:

- Adding tamper-indicating enclosures and conduit around critical components and cabling.
- Adding redundant components, where possible.
- Providing power to the UCVS by building an appropriate Electronics Cabinet with Power Management Module.
- Collecting and storing data from the UCVS.
- Facility specific adaptation.

The development and authorization of an Inspector Review and Analysis Platform (IRAP) algorithm for data analysis will be completed by the IAEA (part of the expected outcome #1 of SGTS-014), but will require consultation with the UCVS developers.

Expected outcome #3	
Established and maintained knowledge of spent fuel in shielding/storing/transporting containers, at all points in their lifecycle, by developing safeguards equipment.	
Supporting R&D Need: T.1.R6	
Key Outputs	Expected Completion Date
Completion of the User (Operations) requirements of new instrumentation to detect and deter the misuse of nuclear material.	May 2020
Development of the instrumentation. The UGET system (Unattended Gamma Emission Tomography) being a potential candidate to address the need.	December 2021

Plans for accomplishing the expected outcome

The safeguards approach at various spent fuel facilities (in particular at the Encapsulation Plant and Geological Repository (EPGR) in Finland) requires the development of new instrumentation to detect and deter the misuse of nuclear material. Upon completion of the User requirements, the development of an ad hoc instrumentation will be completed in the 2020–2021 biennium. The UGET system (Unattended Gamma Emission Tomographic system, which is the unattended version of the PGET) is a system that could potentially address that need.

Expected outcome #4	
Increased proportion of deployed unattended systems that are sustainable, standardized and modular, with increased use of Commercial-Off-The-Shelf (COTS) products.	
Supporting Priority Objectives: T.1 and T.4	
Key Outputs	Expected Completion Date
Evaluation of a TDR (Time Domain Reflectometry) prototype from the USSP.	End of 2020
Development and maintainability support of UMS electronic standard modules (ADM2- and LANL-based modules).	End of 2021

Plans for accomplishing the expected outcome

Plans include the upgrade of MiniGRAND and Shift Register systems, incorporating UDL1 and the Unattended Dual-Current Module (UDCM), and development of user requirements for a COTS data acquisition module, to replace obsolete commercial equipment.

In testing and evaluation of a prototype that uses Time Domain Reflectometry (TDR) technology to determine tampering of UMS cables, evaluation of the prototype device will contribute to the drafting of a MSSP task proposal to seek support for further development by Member States with the potential for commercialization in the future.

5. In-house development tasks

The table below lists internal development activities that will continue, but which will benefit from external contributions to the project. It gives an understanding of how external stakeholders can:

- Complement existing work
- Initiate activities in under-served areas of need
- Avoid duplicate activities

Expected outcome	Task #	Task (Agency's cross reference)	Title task	Description	Expected Completion Date
2	1	Viability study for a new concept of UMS Power Monitor (4.3.2.002-2019.01)		A new approach to measure reactor power using gamma spectrometry will be investigated in terms of technical performance and cost/benefit.	Q1 2020
3	2	Development of an instrument that measures spent CANDU bundles prior to loading into Dry Storage Casks (4.3.2.002-2019.01)		For Canadian CANDU multi-unit stations, a detector system is being developed in-house, to determine if a Dry Storage Cask module containing 96 irradiated CANDU bundles is full. The next step is the construction and testing of prototype detector units.	End of 2020
3	3	UMS for Chornobyl New Safe Confinement (4.3.2.002-2019.01)		At the Chornobyl New Safe Confinement, a UMS will be implemented to monitor exit routes for the removal of Unit 4 structural debris. The goal is to monitor the possible removal of core fuel pieces.	End of 2021
3	4	UMS for encapsulation plant monitoring in Finland (4.3.2.002-2019.01)		Monitoring the flow of spent LWR fuel is required. Simulations to determine key measurement points for verification of flow and appropriate detector types are in progress.	End of 2021
4	5	Implementation of new UMS Data Acquisition module (4.3.2.002-2019.01)		All MiniGrand/Shift register-based UMS will be upgraded with new UDL1 and UDCM data acquisition modules.	End of 2021
4	6	UMS systems upgrade to DC power (4.3.2.002-2019.01)		UMS will be upgraded with new full DC power management hardware.	End of 2021
4	7	Implementation of Fast Current Preamplifier (4.3.2.002-2019.01)		A new Fast Current preamplifier module will be tested in the field.	Q2 2020
4	8	Define and test new UMS neutron and gamma detectors (4.3.2.002-2019.01)		New detectors will be thoroughly tested for specific UMS applications.	End of 2021

6. Attachments

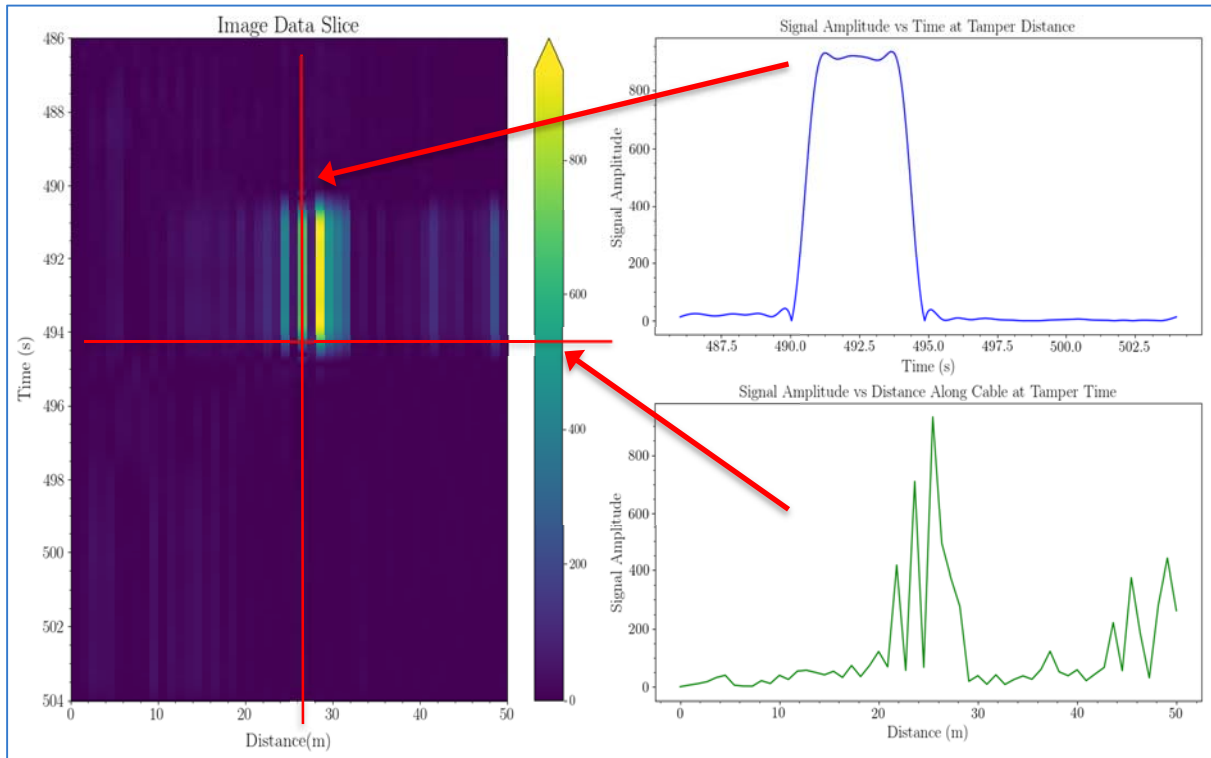

Figure 69: TDR (Time Domain Reflectometry) technique showing typical tamper along the detector cable at about 25 m from the cabinet

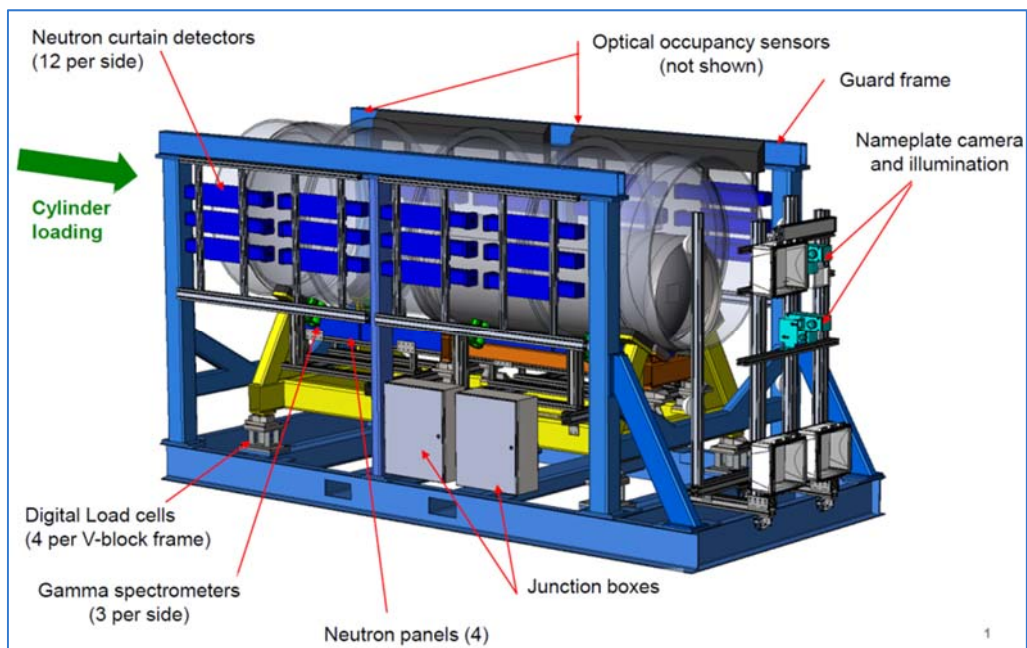

Figure 70: Drawing of the UCVS system



Figure 71: Typical UMS system operating on full DC power with its DC power management module

SGTS-014: Remote Data Transmission and Processing Systems

Project Manager: Angelo Antonio ALESSANDRELLO

1. Overview

This document describes plans for developing, implementing and maintaining remote data transmission (RDT) and data processing systems—to collect, transmit and review data from safeguards equipment installed in facilities around the world—during the period 2020–2021.

Over recent years, the Department has faced challenges from the sheer number of different programs to maintain, inaccessibility of source code or lack of intellectual property (IP) rights. To address these issues, an in-house effort to build an all-in-one review program, and subsequent partnership with Euratom, has resulted in the development of IRAP (Inspector Review and Analysis Platform) and NGSР (Next Generation Surveillance Review). IRAP is now in a 'rolling out' phase for specific facilities and is being used to review and analyse data from many of the Department's unattended monitoring systems (UMS) that are connected to the remote data transmission network. IRAP is already capable of importing facility operator declarations for several facilities and, in the future, IRAP will also have capabilities to review surveillance and electronic seals data and integrate with the IAEA Neutron Coincidence Counting (INCC) program.

A project called CASCADE (Centralized Automated System for Correlated Analysis and Data Evaluation) has commenced, which will incorporate IRAP, NGSР and other software tools, such as the Operator Declaration Data Importer. Future large facilities, including geological repositories, will require 'near real-time' (NRT) data processing capabilities, the development of which form part of CASCADE, to notify the facility operators as soon as possible, if they can proceed in their processes. This project will have some components, for example, NRT application, developed in-house by RMT, while others will be contracted to third parties in collaboration with Euratom. The CASCADE product will fill the current information technology gap related to the absence of a complete software toolset to perform the facility operator declaration verification process.

Most of the funding for the RMTs information collection and analysis development activities, including CASCADE, comes from the Department's regular budget. However, MSSPs may be requested to support specific areas, including the development of NRT tools; assistance with security audits and help with specific data review methods.

Project objective

The main purpose of Remote Data Transmission (RDT) is to connect with systems in the field for the transfer of data, making inspections less frequent and remote systems easier to maintain, which is an important contribution to the effectiveness and efficiency of IAEA safeguards.

The objective is to support the use of RDT through the development, implementation and maintenance of hardware and software tools. The Remote Monitoring Team (RMT) of SGTS is the focal point for equipment software development.

Foreseen challenges

RDT hardware and software tools need to be highly integrated with different systems, including several departmental IT systems. Significant effort is required to develop application upgrades, achieve the correct level of integration with other divisional and departmental software tools and meet current departmental software standards while also maintaining the required level of flexibility for applications that handle data coming from the field.

Top project priorities in 2020–2021

- Develop CASCADE, the top priority for SGTS-014.
- Continue joint development of IRAP and NGSР, as the foundations of CASCADE, with Euratom.
- Install and test new NRT components for application at large facilities in Ukraine.
- Select and authorise new Virtual Private Network (VPN) hardware for the RDT network and, in addition, identify and/or develop an alternative VPN hardware/software with additional security capabilities.
- Continue the practice of requesting security audits of the RMT network.

- Complete the release of ROOGLE3, a program to display real-time RDT system status, with the added feature to monitor hand carried data equipment status and an enhanced capability for integration with other divisional and departmental tools.

Collaborating D&IS projects

- SGIS-002: Information Security and Infrastructure
- SGIS-003: Safeguards Information Systems and System Usability
- SGOA-003: Fukushima Dai-ichi Safeguards
- SGOC-001: Chernobyl
- SGTS-003: Surveillance Techniques
- SGTS-011: Unattended Measurement Techniques

2. Strategy framework linkages

IAEA's Programme and Budget project linkage

The plan and MSSP tasks detailed in this chapter are followed-up and/or coordinated by Agency staff and are aligned with the objectives of the Agency's project #4.3.2.002 Development of instrumentation systems and methodology in *the Agency's Programme and Budget 2020–2021*.

Safeguards Research & Development Plan linkage

Priority Objective	R&D Needs
T.1 Strengthen instrumentation capabilities for verification	T.1.R1 Develop and introduce an integrated system of instrumentation data processing and review, with high level of automation and with unified user interface.
	T.1.R5 Develop improved tools and techniques to enable real time flow measurements of nuclear material, including UF ₆ at enrichment plants and conversion plants, and Pu at reprocessing plants.
	T.1.R9 Strengthen intrusiveness and vulnerability analyses on current and future use of unattended systems, particularly to address any new threats resulting from technology advancements.

3. Progress on expected outcomes, key outputs and tasks from the previous biennium

Expected Outcome #1 from the 2018–2019 Biennium		
In collaboration with Euratom, continued development of the IRAP review programme.		
Supporting R&D Needs: T.1.R1		
Key Outputs	Status	Comments
Deployment of a version of IRAP that includes complete surveillance and electronic seal review, using improved operator declaration integration.	Key output achieved; work continues	Three facilities are fully configured and authorized for the use of IRAP. Facility operator declaration integration was achieved in each. Implementation of electronic seal data has started and should be fully integrated in 2020. NGSR implementation should be concluded by March 2020, with integration by the end of 2020.

Expected Outcome #2 from the 2018–2019 Biennium

Installed and tested new near real-time (NRT) components in large facilities.

Supporting R&D Needs: T.1.R5

Key Outputs	Status	Comments
New near real-time (NRT) components installed and tested in Ukraine in following facilities: ISF-2 (2018) and CSFSF (2019).	Delayed; work in progress	Due to facility delays, NRT has only been installed in ISF2. Testing of the NRT declaration handling capabilities has been successfully conducted at ISF2. ISF2 final test will happen by March 2020, according to latest communicated date of ISF2 Hot Test. CSFSF NRT Application implementation is now planned for 2020.

Expected Outcome #3 from the 2018–2019 Biennium

Improved VPN hardware for the RDT network.

Supporting R&D Needs: T.1.R9

Key Outputs	Status	Comments
Selection and authorization of further VPN hardware for the RDT network.	Key output achieved; work continues	The 'mGuard' VPN was selected and authorized for use in the RDT network. RMT is still examining the market for other VPNs adequate for particular applications (for example, for some facilities, the network security requirements are very high).
Identification of an additional alternate VPN hardware (for example, open source solutions) including development of security enhancements to the hardware/software with support for smart card cryptography tokens.	Key output achieved; work continues	This work is progressing under MSSP task USA E 2384 (Remote Monitoring VPN Hardware Support).

Expected Outcome #4 from the 2018–2019 Biennium

Improved efficiency of equipment maintenance by introducing iOS-based apps, initially to monitor RDT system status.

Supporting Priority Objective: T.1

Key Outputs	Status	Comments
Release of ROOGLE 2	Key output achieved; work continues	As a replacement and upgrade of ROOGLE, ROOGLE2 was completed and deployed and is now in use in the Department. RMT has started the development of ROOGLE3, a modernised version capable of integrating with other divisional and departmental tools (AM, SEQUOIA, etc.) and of monitoring the hand carried data imported in Remote Data Transmission directories using mobile media (SD Cards, External Hard Drive, etc.).

4. Expected outcomes, key outputs and tasks for the 2020–2021 biennium

In order to achieve overall objectives and meet R&D needs, tasks must be initiated, continued and/or finalized during the 2020–2021 biennium. The following expected outcomes serve as an outline for the next 2 years.

Expected outcome #1	
Key Outputs	Expected Completion Date
More efficient data review and verification by inspectors, through the development of CASCADE, adopting the current departmental software standards.	
Supporting R&D Needs: T.1.1.R1 and T.1.1.R5	
Key Outputs	Expected Completion Date
NRT Application for ISF2.	February 2020
Triggered data evaluation for IRAP-authorized facilities.	March 2020
Scheduled/on-demand data evaluation for IRAP-authorized facilities.	July 2020
SGLAN applications and NGSR integration into CASCADE.	January 2021
ISE applications integration into CASCADE.	June 2021
Remote system analysis capability for the Fork Detector (FDET).	September 2021
IRAP deployment and extension of CASCADE to other facilities.	December 2021

Plans for accomplishing the expected outcome

CASCADE will be an integrated tool, helping IAEA inspectors to perform data review and verification tasks more efficiently. It will have the capability to:

- Integrate NDA electronic seals and image data.
- Perform automatic data processing, analysis, evaluation and verification.
- Integrate available facility operator data.
- Automatically produce reports to support verification of facility operator declarations and related reporting on safeguards verification activities.

The intention is that CASCADE will provide a fully integrated view of the 'end to end' verification process, for further review by the Inspectorate.

CASCADE uses the IRAP and NGSR software tools as a foundation and, as such, will allow the IAEA to abandon a plethora of legacy software that is currently in routine use for the facility operator declaration verification process. Furthermore, CASCADE will integrate IRAP and NGSR functionality, in an automated way, to produce outputs that will be available in the Integrated Safeguards Environment (ISE). CASCADE will also expand the features of IRAP and NGSR to support cases where an automatic verification may be needed, to provide the facility operator with "proceed" or "hold messages" for processes where it is not practical to have an inspector available on site. (For example, for the welding of casks following loading and remote verification.)

The first pilot case of an NRT application will be implemented to monitor the nuclear material flows at newly-built conditioning facilities, specifically to count items inserted in a cask before it is sealed and placed in storage. This CASCADE component is linked to the project SGOC-001: Chernobyl and, therefore, is partially supported by the same MSSP tasks. The several parallel activities implemented to achieve this outcome and expected to converge in the 2020–2021 biennium, are:

- The final stages of development of IRAP and NGSR, which will be achieved in collaboration with Euratom.
- The full configuration, in IRAP and NGSR, of facilities under remote data transmission regime.
- The automatization of the manual IRAP/NGSR evaluation, facility by facility.
- The import of relevant facility operator declaration data into CASCADE.
- The creation of an Inspector User Interface, usable in SGLAN and subsequently in ISE, to allow Inspectors to review and, when needed, to correct the produced verification and evaluation reports.

MSSP task USA E 1988 (Expert - Remote Monitoring), is active in providing software development and software engineering expertise in IRAP development. Another MSSP task, USA D 2386 (Junior Professional Officer - Associate Remote Monitoring Engineer) will support this outcome through

participating in CASCADE software development. This project will also collaborate with SGIS-003 to ensure compliance with SGIS IT governance, standards and best practices.

It should be noted that, additionally under CASCADE, there is a task with the long-term objective to move both the analysis reports produced by new RMT software tools, as well as the collected RMT data, into ISE. By doing so, the analysis reports will be automatically available for incorporation into SAFIRE and/or other verification tools.

Expected outcome #2	
Improved VPN hardware for the RDT network. Supporting R&D Need: T.1.R9	
Key Outputs	Expected Completion Date
A tested and authorized Euratom-proposed VPN hardware for use in MSSP-provided test facilities in Germany.	June 2020
Implementation of a new VPN hardware, developed using pfSense (open source VPN secure firmware), with support for smartcard cryptography tokens.	December 2020

Plans for accomplishing the expected outcome

The RMT has estimated that the implementation of an RDT network for safeguards, in those countries allowing RDT presence, is approximately 90% complete; with facilities in India, Argentina and Brazil connected during the last biennium. A 30th Member State was included in the RDT network infrastructure in March 2019. The highest priority now is maintaining (and ideally continuously strengthening) the security of the network. In this regard, the IAEA will continue to test newly-available hardware VPN technologies and request external security audits. These, together with penetration tests by external consultants, assist in gauging the effectiveness of the current hardware security against ever-evolving threats.

RMT is committed to analysing the market for VPN technologies to replace the current one: both for specific installations, where more features are needed than available, and also to be aware of possible replacement technologies to mitigate obsolescence. In this regard, several modern VPNs are currently under analysis by the RMT.

The expected outcome will be achieved by selecting and authorizing a new VPN hardware for the RDT network. Identification of an additional, alternate VPN hardware (for example, open source solutions), including development of security enhancements to the hardware/software with support for smart card cryptography tokens, is also planned.

The current generation of RMT VPNs is in the process of being phased out (end of life is January 2020), with a commercially-available VPN accepted and authorized by the Department as a replacement. This is now being deployed. However, it is in the Agency's best interests to continue to identify additional VPN solutions, especially for specific situations where the facility operators have more stringent network security requirements. In one such case, a VPN solution adopted by Euratom is currently under evaluation. Furthermore, an open-source VPN solution is desirable, as it reduces the risks of relying on a single vendor and allows the IAEA to be involved in 'bug fixes' or the addition of new features. As a result of a review of open-source VPN devices, the RMT has recommended that solutions incorporating hardware that can implement an open source VPN secure firmware(s) be investigated.

A particular area of concern in VPN devices is with regard to key protection. Physical protection of the RDT network components (cables, VPNs, switches, etc.) addresses the security of devices and it is obtained with proper enclosures/cabinets at facilities and at IAEA HQ. Nevertheless, adding to that, the VPN capabilities to protect its keys will enhance RDT network security better ensuring the integrity of data during transmission. In this respect, an open-source solution such as pfSense has the advantage of potentially being modified to support additional strong key protection (for example, by using a smartcard cryptography token). MSSP task USA E 2384 (Remote Monitoring VPN Hardware Support) is active in supporting this outcome by providing development with the pfSense prototype VPN solution.

MSSP support has been important for other aspects of RDT network infrastructure, including through MSSP tasks USA E 1735 (Testing of Secure Communications for Remote Monitoring), CAN E 1931 (Vulnerability Assessment of the Remote Monitoring Network Infrastructure) and GER E 1859 (Testing and Implementation of Data Remote Transmission Security). The project anticipates requesting further support in the future.

Expected outcome #3	
Improved efficiency of equipment maintenance, by upgrading ROOGLE. Supporting Priority Objective: T.1	
Key Outputs	Expected Completion Date
Integration of ROOGLE3 data with the Access Management System (AM).	January 2020
Integration of ROOGLE3 data with SMT and SEQUOIA.	June 2020
Hand carried data monitored by ROOGLE3.	December 2020
Integration of ROOGLE3 data with CASCADE.	June 2021
Move ROOGLE3 to the production environment.	January 2021

Plans for accomplishing the expected outcome

ROOGLE is an in-house-developed, read-only application that displays the latest status of all systems under RDT. It has been operational for over six years, and it is now in its second version (ROOGLE2) with enhanced user interfaces and 'status of health' display capabilities.

The capabilities of this application need to expand as there is a requirement to interface ROOGLE with other systems such as:

- SEQUOIA (the Safeguard equipment asset management tool)
- SMT (the SGTS ticketing system)
- CASCADE
- Authorisation Management (AM) tool

and to monitor the hand-carried data imported in Remote Data Transmission directories using mobile media (SD Cards, External Hard Drive, etc.) through which departmental staff members get access to particular information.

This expansion of capabilities can only be performed by using more modern software. The modernisation activities are already underway using internal resources; the inclusion of proper interfaces to other systems will then follow.

Also scheduled for this biennium is the modernisation of the two RMT file storages—both the one related to RDT data and the one related to data transferred from removable media taken from the field—for greater efficiency in data extraction and distribution.

Because of the confidentiality level of the RDT data, coming from safeguard equipment looking at nuclear processes and/or nuclear material storages, MSSP support is likely to be called just upon the provision of experts (CFEs) who could help in the development of ROOGLE3. This project will also collaborate with SGIS-003 to ensure compliance with SGIS IT governance, standards and best practices.

5. In-house development tasks

The table below lists internal development activities that will continue, but which will benefit from external contributions to the project. It gives an understanding of how external stakeholders can:

- Complement existing work
- Initiate activities in under-served areas of need
- Avoid duplicate activities

Expected outcome	Task #	Task Title (Agency's task cross reference)	Description	Expected Completion Date
1	1	CASCADE Development	CASCADE is an umbrella project, with the aim to integrate IRAP, NGSR and facility operator declaration data within a single application that will present SG equipment data in a simpler way to the inspector. It will also facilitate facility verification and verification reports. It will be connected with several departmental IT systems,	December 2021

			such as SAFIRE. The framework of the project also includes migration of SG equipment data from SGLAN into ISE.	
2	2	Improved VPN hardware for the RDT network	Selection and authorization of further VPN hardware for the RDT network, including the Euratom VPN box to be used in German facilities	June 2020
3	3	ROOGLE Development	In-house development of ROOGLE3, a modernized version of the ROOGLE2, capable of interfacing with other divisional and departmental tools (for example, AM, SEQUOIA, etc.) and to monitor the hand carried data imported in Remote Data Transmission directories using mobile media (SD Cards, External Hard Drive, etc.).	December 2020

6. Attachments

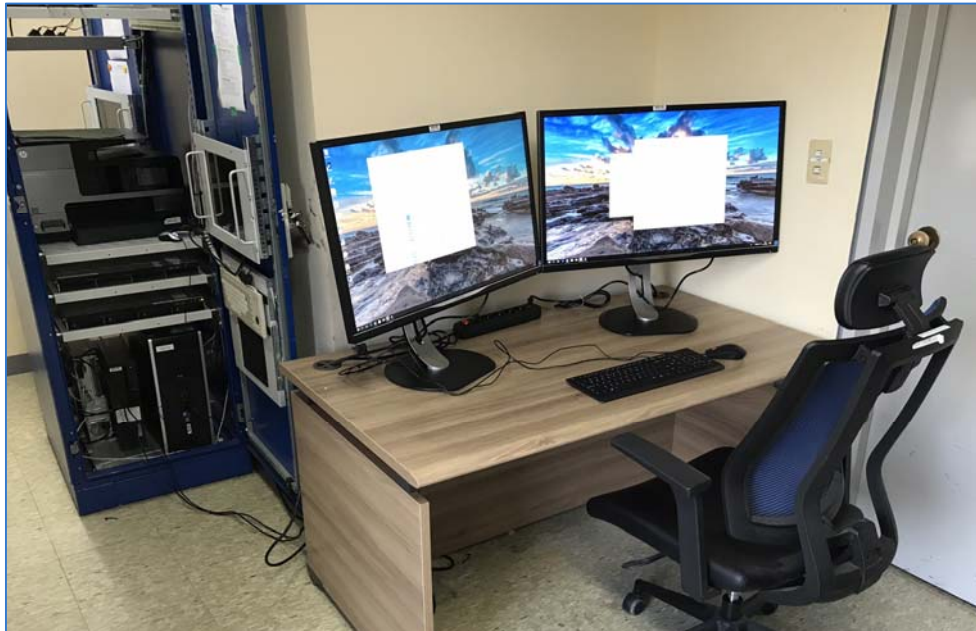

Figure 72: Newly-installed IRAP review station at Hilton IAEA Office in Wolsong (ROK). All ROK data are available to this station for efficient review by IAEA inspectors.

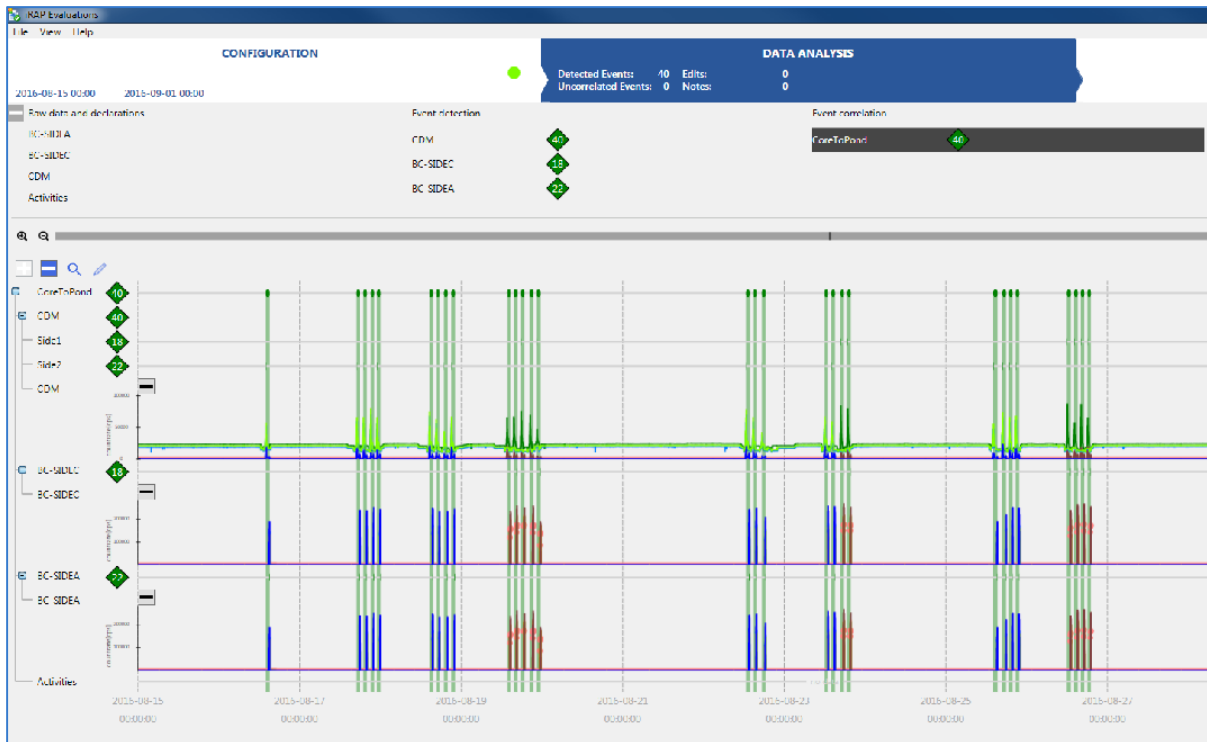

Figure 73: Screenshot of analysed data from the Inspector Review and Analysis Platform (IRAP) application.

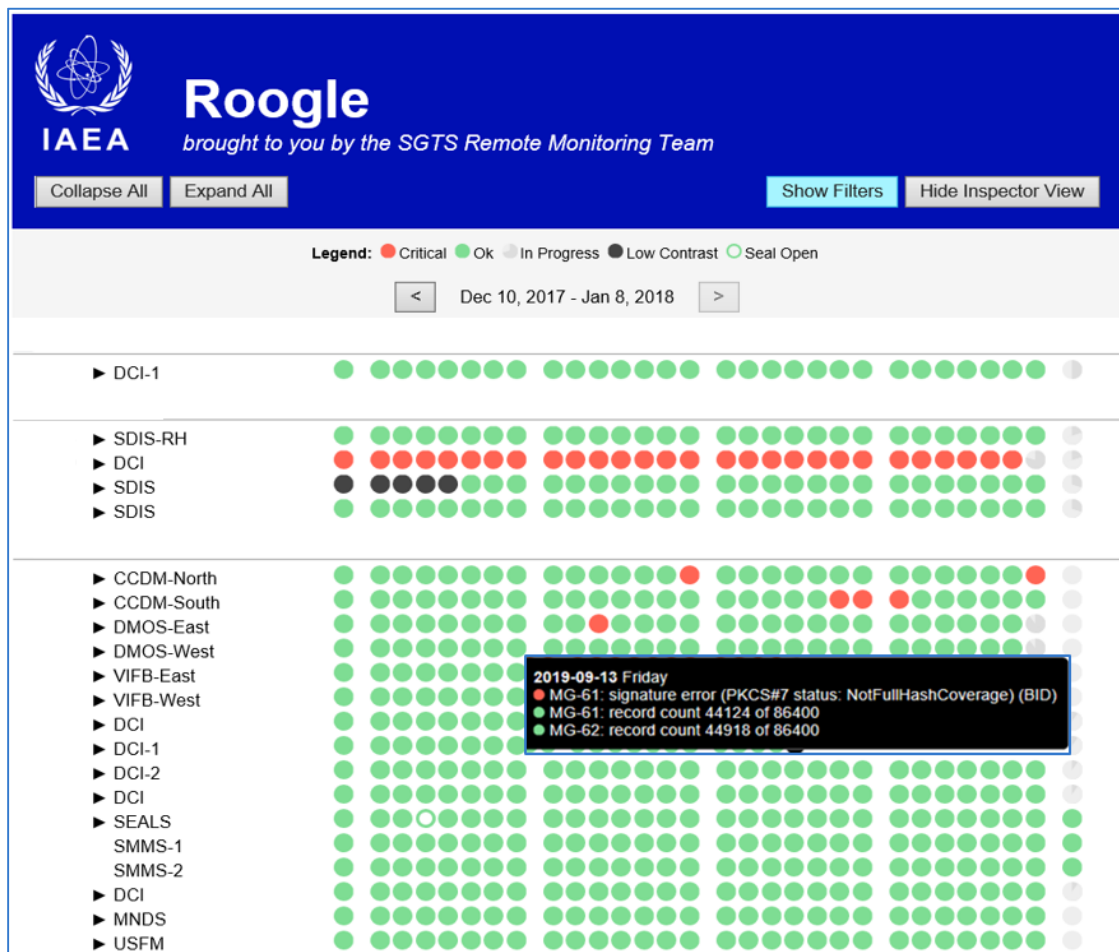

Figure 74: Screenshot of Roogle2 with 'status of health' information

SGVI-001: JCPOA Verification

Project Manager: Andrew CATTON

1. Overview

This chapter describes plans specific to supporting implementation of the Joint Comprehensive Plan of Action (JCPOA) for the 2020–2021 biennium.

Project objective

The overall objective is to develop and implement measures for the effective and efficient verification and monitoring of Iran’s nuclear-related commitments under the JCPOA.

Foreseen challenges

As part of the transparency measures under the JCPOA, IAEA inspectors have enhanced access to uranium mines and mills and continuous surveillance of centrifuge manufacturing and storage locations. These measures go beyond the scope of Iran’s Comprehensive Safeguards Agreement (CSA) and Additional Protocol (AP) and require IAEA inspectors and analysts to be specially equipped and trained.

Top project priority for the 2020–2021 biennium

The top priority is to maintain capabilities for the verification and monitoring of Iran’s nuclear-related commitments under the JCPOA.

2. Strategy framework linkages

IAEA’s Programme and Budget project linkage

The plan and MSSP tasks detailed in this chapter are followed-up and/or coordinated by Agency staff and are aligned with the objectives of the Agency’s project #4.2.1.002 Verification monitoring of Iran’s JCPOA nuclear related commitments in the *Agency’s Programme and Budget 2020–2021*.

Safeguards Research & Development Plan linkage

Priority Objective		R&D Needs	
V.1	Strengthen information collection and analysis	V.1.R3	Further integrate safeguards information to strengthen all-source information analysis and make it more user-friendly (e.g. via the Collaborative Analysis Platform).
W.1	Reform human resource management	W.1.R1	Develop and maintain, through training, new expertise required by the Department, where needed, with the help of Member States.

Collaborating D&IS projects

- SGCP-102: Training
- SGIM-003: Information Analysis
- SGIS-003: Information Systems and System Usability
- SGTS-011: Unattended Measurements Techniques

3. Progress on expected outcomes, key outputs and tasks from the previous biennium

Expected Outcome #1 from the 2018–2019 Biennium		
Maintain capabilities for the verification and monitoring of Iran’s nuclear-related commitments under the JCPOA. (In support of V.1.R3 and W.1.R1)		
Key Outputs	Status	Comments
Contributions to the development of the Natural Language Processing task, advising on the move from the development stage to the deployment stage.	Key output achieved; work completed	Task completed. Input for the Natural Language Processing (NLP) programme has been received from MSSPs; the project is now moving to an internal development and implementation phase.
Continued deployment of specific training for members of the Office for Verification in Iran.	Key output achieved; work continues	The training course has been well received by SGVI, and a continuation is planned.

4. Expected outcomes, key outputs and tasks for the 2020–2021 biennium

In order to achieve overall objectives and meet R&D needs, tasks must be initiated, continued and/or finalized during the 2020–2021 biennium. The following expected outcomes serve as an outline for the next 2 years.

Expected outcome #1	
Continued development and deployment of training, tools and techniques specific to supporting the JCPOA. Supporting R&D Needs: V.1.R3 and W.1.R1	
Key Outputs	Expected Completion Date
Conduct training in Carbon Fibre Mechanical Testing for SGVI Inspectors.	December 2021

Plans for accomplishing the expected outcome

As part of the JCPOA, the Agency is required to verify certain aspects relating to the definitions agreed on implementation day (Annex I, section I, paragraph 54). To do this, specialized training is required and supplied through MSSP task FRA B 2405 (Carbon Fibre Mechanical Testing Training Course for Inspectors). The technical content of the training, required to fulfil the needs of the Inspectors and Technical Experts involved in verification activities of the JCPOA in Iran, was discussed between SGVI and the French Support Programme in 2018. The training was assessed as fully consistent with the technical needs of the participants. SGVI had two Carbon Fibre Mechanical Testing Training Courses in 2018–2019. Further training may be requested to accommodate developing needs during the 2020–2021 biennium.

Appendix 1: The Department's Strategic Plan-on-a-Page

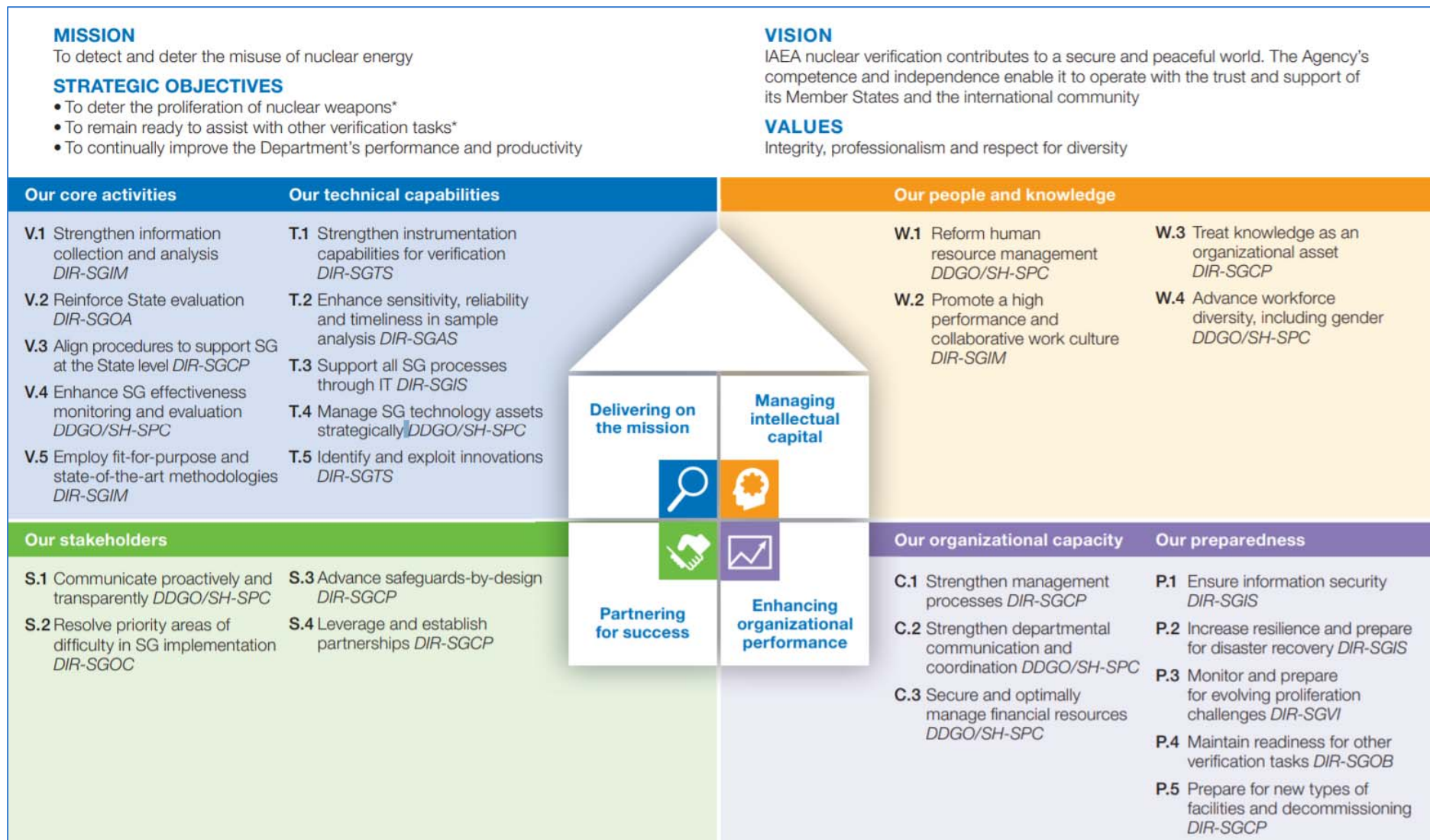

Appendix 2: R&D Needs with Corresponding D&IS Projects

		DDGO-001	SGAS-001	SGAS-002	SGAS-003	SGCP-003	SGCP-004	SGCP-101	SGCP-102	SGIM-002	SGIM-003	SGIM-007	SGIM-008	SGIM-009	SGIS-002	SGIS-003	SGOA-002	SGOA-003	SGOC-001	SGTS-001	SGTS-002	SGTS-003	SGTS-008	SGTS-011	SGTS-014	SGVI-001		
V.1 Strengthen information collection and analysis																												
V.1. R1	Enhance the set of expert tools necessary to process the variety of SG-relevant information and implement them, with emphasis on timely responses and cost-effectiveness.									●	●			●		●												
V.1. R2	Make use of new sources of openly available information, including from multimedia, and address the associated information management needs.										●																	
V.1. R3	Further integrate safeguards information to strengthen all-source information analysis and make it more user-friendly.									●	●					●												●
V.2 Reinforce State evaluation																												

		DDGO-001	SGAS-001	SGAS-002	SGAS-003	SGCP-003	SGCP-004	SGCP-101	SGCP-102	SGIM-002	SGIM-003	SGIM-007	SGIM-008	SGIM-009	SGIS-002	SGIS-003	SGOA-002	SGOA-003	SGOC-001	SGTS-001	SGTS-002	SGTS-003	SGTS-008	SGTS-011	SGTS-014	SGVI-001	
V.2. R1	Develop a set of reference materials to assist SEGs in the assessment of a State's capability to accomplish acquisition path steps which take into account the level of maturity of the State's nuclear fuel cycle and associated technical capabilities.					●																					
V.4 Enhance SG effectiveness monitoring and evaluation																											
V.4. R1	Identify and deploy analytical tools, including data visualization, to better measure and analyse performance and take advantage of capabilities provided by MOSAIC.									●		●				●											
V.4. R2	Evaluate process for introduction of Hypothesis testing approaches for nuclear material measurements, as an alternate to quantification methodology.																										
V.5 Employ fit-for-purpose and state-of-the-art methodologies																											

V.5. R1	Upgrade existing and develop new statistical methodologies applied to the: <ul style="list-style-type: none"> • Evaluation of quantitative and qualitative verification data including at the State level. • Measurement of verification performance and the associated level of confidence at the facility and state level. • Design of random verification schemes. 	DDGO-001	SGAS-001	SGAS-002	SGAS-003	SGCP-003	SGCP-004	SGCP-101	SGCP-102	SGIM-002	SGIM-003	SGIM-007	SGIM-008	SGIM-009	SGIS-002	SGIS-003	SGOA-002	SGOA-003	SGOC-001	SGTS-001	SGTS-002	SGTS-003	SGTS-008	SGTS-011	SGTS-014	SGVI-001
V.5. R2	Strengthen knowledge of the elemental and isotopic signatures of the nuclear fuel cycle and processes that are specifically detectable through material characterization and environmental sample analyses, and develop expert systems and methodologies that advance data evaluation and enhance continuity of knowledge.										●															

		DDGO-001	SGAS-001	SGAS-002	SGAS-003	SGCP-003	SGCP-004	SGCP-101	SGCP-102	SGIM-002	SGIM-003	SGIM-007	SGIM-008	SGIM-009	SGIS-002	SGIS-003	SGOA-002	SGOA-003	SGOC-001	SGTS-001	SGTS-002	SGTS-003	SGTS-008	SGTS-011	SGTS-014	SGVI-001	
V.5. R3	Explore data analysis methods and tools to strengthen the synthesis and evaluation of information.										●		●			●	●										
T.1 Strengthen instrumentation capabilities for verification																											
T.1. R1	Develop and introduce an integrated system of instrumentation data processing and review, with high level of automation and with unified user interface.																									●	
T.1. R2	Develop the Next Generation Surveillance Review software.																										●
T.1. R3	Assess existing techniques to detect misuse of reprocessing plants.																●										●
T.1. R4	Improve tools and techniques to enable timely, potentially real time, detection of HEU production in LEU enrichment plants.																								●		

		DDGO-001	SGAS-001	SGAS-002	SGAS-003	SGCP-003	SGCP-004	SGCP-101	SGCP-102	SGIM-002	SGIM-003	SGIM-007	SGIM-008	SGIM-009	SGIS-002	SGIS-003	SGOA-002	SGOA-003	SGOC-001	SGTS-001	SGTS-002	SGTS-003	SGTS-008	SGTS-011	SGTS-014	SGVI-001
T.1. R5	Develop improved tools and techniques to enable real time flow measurements of nuclear material, including UF ₆ at enrichment plants and conversion plants, and Pu at reprocessing plants.																●			●		●		●	●	
T.1. R6	Develop safeguards equipment to establish and maintain knowledge of spent fuel in shielding/storage/transport containers at all points in their life cycle.																			●				●		
T.1. R7	Evaluate implementation potential for calorimetry of plutonium samples when the commonly available passive neutron multiplicity measurements are not feasible.																			●						
T.1. R8	Develop in-field alpha spectrometers (including sample preparation) for nuclear material identification																									

		DDGO-001	SGAS-001	SGAS-002	SGAS-003	SGCP-003	SGCP-004	SGCP-101	SGCP-102	SGIM-002	SGIM-003	SGIM-007	SGIM-008	SGIM-009	SGIS-002	SGIS-003	SGOA-002	SGOA-003	SGOC-001	SGTS-001	SGTS-002	SGTS-003	SGTS-008	SGTS-011	SGTS-014	SGVI-001		
	and isotopic composition analysis.																											
T.1. R9	Strengthen intrusiveness and vulnerability analyses on current and future use of unattended systems, particularly to address any new threats resulting from technology advancements.																						●			●		
T.2 Enhance sensitivity, reliability and timeliness in sample analysis																												
T.2. R1	Improve analytical timeliness of dealing with special and high priority demands for analysis by means of the reduction of sample size, the application of in-situ analysis and by strengthening the response regime.		●																									
T.2. R2	Further improve the quality assurance and control for the Agency's NWAL for safeguards, including SAL, in the area of particle analysis in particular.			●	●																							

		DDGO-001	SGAS-001	SGAS-002	SGAS-003	SGCP-003	SGCP-004	SGCP-101	SGCP-102	SGIM-002	SGIM-003	SGIM-007	SGIM-008	SGIM-009	SGIS-002	SGIS-003	SGOA-002	SGOA-003	SGOC-001	SGTS-001	SGTS-002	SGTS-003	SGTS-008	SGTS-011	SGTS-014	SGVI-001	
T.2. R3	Support the improvement of Member States' analytical quality for nuclear material accountancy.		●		●																						
T.2. R4	Develop/expand a set of reference materials with NWAL assistance, and produce/ distribute working reference materials to support Member States' analytical quality.		●	●	●																						
T.2. R5	Continue to reduce and manage nuclear material holdings stored at the NML in line with safeguards needs, and identify long-term sustainable solutions for disposal of nuclear materials, particularly plutonium and HEU.		●																								

T.2. R6	Develop and implement methods to detect signatures of nuclear activities in environmental samples including: <ul style="list-style-type: none"> • Age determination of U and Pu relevant to the origin of nuclear materials. • Analysis of impurities relevant to the origin of source materials. • Particles morphology for identifying operational processes. • Reliably finding smaller particles of interest in an excess of background material. • Isotopic characterization of Pu containing particles using FT-LAICPMS and LG-SIMS. 	DDGO-001	SGAS-001	SGAS-002	SGAS-003	SGCP-003	SGCP-004	SGCP-101	SGCP-102	SGIM-002	SGIM-003	SGIM-007	SGIM-008	SGIM-009	SGIS-002	SGIS-003	SGOA-002	SGOA-003	SGOC-001	SGTS-001	SGTS-002	SGTS-003	SGTS-008	SGTS-011	SGTS-014	SGVI-001
T.2 Support all SG processes through IT																										
T.3. R1	Further develop the State Declarations													●		●										

		DDGO-001	SGAS-001	SGAS-002	SGAS-003	SGCP-003	SGCP-004	SGCP-101	SGCP-102	SGIM-002	SGIM-003	SGIM-007	SGIM-008	SGIM-009	SGIS-002	SGIS-003	SGOA-002	SGOA-003	SGOC-001	SGTS-001	SGTS-002	SGTS-003	SGTS-008	SGTS-011	SGTS-014	SGVI-001	
	Portal as a tool that optimizes the quality and usability of State-declared information and enhances the State-Secretariat communication on State declarations.																										
T.3. R2	As part of STEPS project, re-engineer and integrate all the legacy systems used for the statistical evaluation of State declared and verification data and the probabilistic calculations that inform verification.											●				●											
T.3. R3	Build on the development of geographic information system (GIS) technology to enhance geo-based information sharing and related analysis.									●						●											
T.3. R4	Maintain and continue to upgrade the environmental sampling database and the process modelling tools as well as the											●															

		DDGO-001	SGAS-001	SGAS-002	SGAS-003	SGCP-003	SGCP-004	SGCP-101	SGCP-102	SGIM-002	SGIM-003	SGIM-007	SGIM-008	SGIM-009	SGIS-002	SGIS-003	SGOA-002	SGOA-003	SGOC-001	SGTS-001	SGTS-002	SGTS-003	SGTS-008	SGTS-011	SGTS-014	SGVI-001	
	database and tools that support trace elements analysis.																										
T.3. R5	Develop updated software tools for use by SRAs in creating and submitting accountancy reports and additional protocol declarations.													●		●											
T.4 Manage SG technology assets strategically																											
T.4. R1	Execute a long-term maintenance and replacement plan for the SG IT system as a follow-up to MOSAIC.	●							●							●											
T.4. R2	Develop and execute a long-term replacement plan for analytical equipment at SAL, with appropriate mix of regular and extra-budgetary funds.	●																									
T.5 Identify and exploit innovations																											
T.5. R1	Identify, evaluate and test promising applications of robotics and machine learning/artificial																										●

		DDGO-001	SGAS-001	SGAS-002	SGAS-003	SGCP-003	SGCP-004	SGCP-101	SGCP-102	SGIM-002	SGIM-003	SGIM-007	SGIM-008	SGIM-009	SGIS-002	SGIS-003	SGOA-002	SGOA-003	SGOC-001	SGTS-001	SGTS-002	SGTS-003	SGTS-008	SGTS-011	SGTS-014	SGVI-001	
	intelligence to improve the effectiveness and efficiency of safeguards.																										
T.5. R2	Identify areas in which technology challenges could be an asset for developing the Department's technologies and methodologies.																						●				
T.5. R3	Monitor the potential utility of block chain technology for safeguards applications.																										
T.5. R4	Define requirements for SG surveillance technology required beyond the next generation surveillance system.																					●					
T.5. R5	Develop training tools using technologies such as virtual reality, immersive learning systems and web-based training.									●				●													
T.5. R6	Investigate and test fieldable neutron counting systems reducing the use of ³ He																										

		DDGO-001	SGAS-001	SGAS-002	SGAS-003	SGCP-003	SGCP-004	SGCP-101	SGCP-102	SGIM-002	SGIM-003	SGIM-007	SGIM-008	SGIM-009	SGIS-002	SGIS-003	SGOA-002	SGOA-003	SGOC-001	SGTS-001	SGTS-002	SGTS-003	SGTS-008	SGTS-011	SGTS-014	SGVI-001	
	or offering equivalent functional and technical alternatives.																										
T.5. R7	Develop and evaluate alternatives to photo-multiplier tubes for large neutron or gamma scintillation detectors.																										
T.5. R8	Develop alternative fast neutron detectors that improve effectiveness and fieldability.																●				●						
T.5. R9	Develop large room-temperature semiconductor medium- resolution gamma spectrometers to replace scintillation detector systems.																				●						
T.5. R10	Develop new Sealing System Technologies with improved security and economy.																					●					
W.1 Reform human resource management																											
W.1. R1	Develop and maintain, through training, new expertise required by the Department, where needed, with the help of Member States.							●	●	●						●											●

		DDGO-001	SGAS-001	SGAS-002	SGAS-003	SGCP-003	SGCP-004	SGCP-101	SGCP-102	SGIM-002	SGIM-003	SGIM-007	SGIM-008	SGIM-009	SGIS-002	SGIS-003	SGOA-002	SGOA-003	SGOC-001	SGTS-001	SGTS-002	SGTS-003	SGTS-008	SGTS-011	SGTS-014	SGVI-001		
S.2 Resolve priority areas of difficulty in SG implementation																												
S.2. R1	Develop training material and remote delivery methods to support SRA training with reduced costs and increased accessibility.													●														
S.3 Advance safeguards-by-design																												
S.3. R1	Identify and pursue opportunities for the Agency and Member States to promote the early consideration of safeguards among the nuclear industry.				●			●																				
C.1 Strengthen management processes																												
C.1. R1	Develop effective and sustainable strategic management processes to enable effective horizontal and vertical strategy execution.					●																						
P.1 Ensure information security																												
P.1. R1	Improve the capability to quickly identify and react to security events within SG information systems.													●														

		DDGO-001	SGAS-001	SGAS-002	SGAS-003	SGCP-003	SGCP-004	SGCP-101	SGCP-102	SGIM-002	SGIM-003	SGIM-007	SGIM-008	SGIM-009	SGIS-002	SGIS-003	SGOA-002	SGOA-003	SGOC-001	SGTS-001	SGTS-002	SGTS-003	SGTS-008	SGTS-011	SGTS-014	SGVI-001	
P.1. R2	Improve Information Security capabilities in areas of risk: management, auditing and reporting; vulnerability management; threat intelligence; and improve processes, procedures and standards.							●							●												
P.2 Increase resilience and prepare for disaster recovery																											
P.2. R1	Address requirements for carrying out mission-critical functions in case of disasters.														●												
P.3 Monitor, assess and prepare for evolving nuclear proliferation challenges																											
P.3. R1	Maintain awareness of changes in the nuclear landscape and associated proliferation risks, including the impact of non-State actors on the safeguards system.					●	●																				
P.4 Maintain readiness for other verification tasks																											
P.4. R1	Enhance readiness to resume safeguards/verification/monitoring activities in																										

		DDGO-001	SGAS-001	SGAS-002	SGAS-003	SGCP-003	SGCP-004	SGCP-101	SGCP-102	SGIM-002	SGIM-003	SGIM-007	SGIM-008	SGIM-009	SGIS-002	SGIS-003	SGOA-002	SGOA-003	SGOC-001	SGTS-001	SGTS-002	SGTS-003	SGTS-008	SGTS-011	SGTS-014	SGVI-001	
	the DPRK, when so requested.																										
P.4. R2	Assist with Chernobyl and Fukushima related activities as requested.																	●	●								
P.5 Prepare for new types of facilities and decommissioning																											
P.5. R1	Address identified gaps in facility-specific guidance, training and tools for conducting verification activities during decommissioning.				●																						
P.5. R2	Based on the prospects and timing for emerging nuclear fuel cycle facilities develop and deploy as appropriate: safeguards concepts, tools, techniques and training.				●																						

Appendix 3: Abbreviations and Acronyms

AFTAC	Air Force Technical Applications Center
AI	Artificial Intelligence
AIPs	Annual Implementation Plans
AM	Authorization Management
AMGB	Advanced Material Accountancy Glove Box
AMP	Asset Management Plan
ANSTO	Australian Nuclear Science and Technology Organization
AOLS	Active Optical Loop Seal
AP	Additional Protocol
APA	Acquisition Path Analysis
APS	Additional Protocol System
APSN	Asian Pacific Safeguards Network
ARN	Nuclear Regulatory Authority of Argentina
ASTM	American Society for Testing and Materials
AUAS	Active Universal Asymmetric Seal
AWE	Atomic Weapons Establishment
BC/DR	Business continuity and disaster recovery
BPMN	Business Process Model and Notation
BWR	boiling water reactor
C/S	comprising surveillance (SGOC-001)
C/S	Dual Containment and Surveillance (SGTS-003)
CAP	Collaborative Analysis Platform
CASCADE	Centralized Automated System for Correlated Analysis and Data Evaluation
CDZT	Cadmium-zinc-telluride
CEA	Commissariat à l'Énergie Atomique et aux Énergies Alternatives
CETAMA	Commission d'Établissement des Méthodes d'Analyse
CIAE	China Institute of Atomic Energy
CIE	Comprehensive Inspection Exercise
CLP4NET	IAEA e-learning platform (Moodle-based system)
COMPUCEA	Combined Procedure for Uranium Concentration and Enrichment Assay
CONOPS	concept of operations
COTS	commercial off-the-shelf
CPC	Strategic Planning and External Coordination Section
CPC	controlled potential coulometry
CPD	Process Design Section
CRMs	certified reference materials
CRPS	Cask Radiation Profiling System
CSA	Comprehensive Safeguards Agreement
CSI	commercial satellite imagery
CSM	comprehensive security management
CTGS	Compact Tomographic Gamma Scanner
CTR	Training Section
D&IS	Development and Implementation Support
DA	destructive analysis
DC	direct current

DDGO	Deputy Director General for Safeguards
DIE	Design Information Examination
DIQ	Design Information Questionnaire
DIV	Design Information Verification
DOE	Department of Energy
DPRK	Democratic People's Republic of Korea
EDS	energy-dispersive X-ray spectrometry
EORC	EOSS Reader Consolidator
EOSS	Electronic Optical Sealing System
EQRAIN	Étude de la Qualité des Résultats d'Analyse dans l'Industrie Nucléaire
ES	Environmental Sampling
ESDB	Environmental Sampling Database
eSF	Electronic State File
ESL	Environmental Sample Laboratory
ETW	Emerging Technologies Workshop
FDET	Fork Detector
FIB	Focused Ion Beam
FNCL	fast neutron uranium collar
FT	Fission-Track
FT-TIMS	fission-track thermal ionization mass spectrometry
FZJ	Forschungszentrum Jülich
GCEP	Gas Centrifuge Enrichment Plant
GDI	Geo-Based Data Integration
GES	Geospatial Exploitation System
GIS	geographic information system
GLAS	glass seal
GUI	graphical user interface
HCES	Hot Cell Enclosure for Sample
HKED	hybrid k-edge densitometry
HTR-PM	High Temperature Gas Cooled Reactor Pebble Modules
HW	hardware
IAEA	International Atomic Energy Agency
ICAS	Introductory Course on Agency Safeguards
ICVD	improved Cerenkov viewing device
IFC	Nuclear Fuel Cycle Analysis Section
ILC	Inter-Laboratory Comparison (Exercise)
INSEN	International Nuclear Security Education Network
IP	intellectual property
IPSAS	International Public Sector Accounting Standards
IRAP	Inspector Review and Analysis Platform
IRD	Instituto de Radioproteção e Dosimetria
IRIS	Instrument Record Integrator for Safeguards
ISE	Integrated Safeguards Environment
ISF-2	Chornobyl site at the Interim (dry) Spent Fuel Storage Facility 2 and the associated Conditioning Facility
ISMS	Information Security Management System
ISO	International Organization for Standardization
ISSAS	State Systems of Accounting for and Control of Nuclear Material

IT	Information technology
IAEA	Japan Atomic Energy Agency
JCPOA	Joint Comprehensive Plan of Action
J-MOX	JNFL MOX Fuel Fabrication Plant
JNFL	Japan Nuclear Fuel Ltd.
JRC	Joint Research Centre (European Commission)
JTC	Joint Technical Committee
KAERI	Korea Atomic Energy Research Institute
KLt-40S	transportable (floating) nuclear power plant (type of small modular reactor)
KMP	Key Measurement Point
KPI	Key Performance Indicators
KRI	Khlopin Radium Institute
LA-ICPMS	Laser Ablation Inductively Coupled Plasma Mass Spectrometry
LANIE	CEA Laboratoire d'Analyses Nucléaires Isotopiques et Élémentaires
LANL	Los Alamos National Laboratory
LCCT	Laser Curtain for Containment
LEU	low enriched uranium
LG-SIMS	large geometry-secondary ion mass spectrometry
LIBS	Laser induced breakdown spectrometer
LIMS	Laboratory Information Management System
LLNL	Lawrence Livermore National Laboratory
LMA	Laboratory for Microparticle Analysis
LMD	laser micro dissector
LOFs	locations outside facilities
LSD	large-size dried
LWR	light-water reactor
MBA	material balance area
MBE	material balance evaluation
MCAT	Multichannel Analyser – Touch
MC-ICPMS	multi-collector Coupled Plasma Mass Spectrometer
MCIK	Multi Components Inspector Kit
MEMS	Microelectromechanical Systems
MOSAIC	Modernization of Safeguards Information Technology (project)
MOX	mixed oxide
MSDES	Mass Spectrometry Data Evaluation System
MSSP	Member State Support Programme
MTA	Magyar Tudományos Akadémia
MTS	Medium Term Strategy
MUF	material unaccounted for
NBL	New Brunswick Laboratory
NDA	non-destructive assay
NDAS	Non-Destructive Assay Services
NFC	nuclear fuel cycle
NGSR	Next Generation Surveillance Review
NGSS	Next Generation Surveillance System
NMA	Nuclear Material Accountancy
NML	Nuclear Material Laboratory
NNL	National Nuclear Laboratory

NPL	UK National Physical Laboratory
NRT	near real-time
NRTA	Near Real Time Accountancy (SGOA-002)
NRTA	Near Real Time Application (SGTS-014)
NSC	New Safe Confinement
NSNS	Department of Nuclear Safety and Security
NU	natural uranium
NUSIMEP	Nuclear Signatures Inter-laboratory Measurement Evaluation Programme
NWAL	Network of Analytical Laboratories
OASM	Open Air Spent Fuel Monitor
OLEM	On-Line Enrichment Monitor
ORNL	Oak Ridge National Laboratory
OSINT	open source intelligence
OSIS	Open Source Information System
OSL	On-Site Laboratory
PGET	Passive Gamma Emission Tomography
PKI	Public Key Infrastructure
PM	Physical Model
PNNL	Pacific Northwest National Laboratory
POC	Point of Contact
POF	Plastic Optical Fiber
POI	particles-of-interest
PR3	Protocol Reporter 3
Pu	Plutonium
PWR	Pressurized water reactor
QA/QC	quality assurance/quality control
QC	quality control
QCVS	Quality Control Verification Software
QMS	Quality Management System
R&D	Research and Development
RCT	Reports Creation Tool
RCVD	Robotized Cerenkov Viewing Device
RDT	Remote data transmission
REIMEP	Regular European Inter-laboratory Measurement Evaluation Programme
RF	Radio Frequency
RFID	Radio-Frequency Identification
RMT	Remote Monitoring Team
RRP	Rokkasho reprocessing plant
SALIMS	Safeguards Analytical Laboratory Information Management System
SAR	Synthetic Aperture Radar
SAT	Systematic Approach to Training
SDP	State Declarations Portal
SEA	Strategy Execution Application
SEG	State Evaluation Groups
SEM	Scanning Electron Microscopy
SEM/EDX	scanning electron microscope/energy dispersive x-ray spectroscopy
SEQUOIA	Safeguard equipment asset management tool
SER	State Evaluation Report

SF	Spent Fuel
SFA	Spent Fuel Assembly
SG	Safeguards
SG IT DR	Safeguards Information Technology Disaster Recovery (team)
SGAS	Office of Safeguards Analytical Services
SGCP	Division of Concepts and Planning
SGIM	Division of Information Management
SGIS	Office of Information and Communication Systems
SGMD	Safeguards Master Data
SGOA	Division of Safeguards Operations A
SGOB	Division of Operations B
SGOC	Division of Operations C
SGSR	Next Generation Surveillance Review
SGTS	Division of Technical and Scientific Services
SGVI	Office for Verification in Iran
SIMS	Secondary Ion Mass spectrometry
SIR	Safeguards Implementation Report
SLA	State Level Approach
SLC	State Level Concept
SME	Safeguards Measurement Evaluation
SMEs	subject matter experts
SMRs	small modular reactors
SMT	SGTS ticketing system
SNRIs	short notice random inspections
SP-1	Task proposal
SPCT	Support Programme Coordination Team
SPRICS	Support Programme Information and Communication System
SQP	Small Quantity Protocol
SRA	States or Regional Authorities
SSACs	State Systems of Accounting for and Control of Nuclear Material
SSDH	State Supplied Data Handling
SSTDR	Spread Spectrum Time Domain Reflectometry
STEPS	Statistical Evaluation Platform for Safeguards
STP	Scientific and Technical Panel
STR	Safeguards Technical Report
SW	software
SWIR	Short Wave Infrared
TARS	Technical Assistance Review System
TBT	the Big Table
TDR	Time Domain Reflectometry
TEPCO	Tokyo Electric Power Company
TIMS	thermal ionization mass spectrometry
U	uranium
UCVS	Unattended Cylinder Verification System
UGET	Unattended Gamma Emission Tomography
UHF	ultra-high frequency
UMS	Unattended Monitoring Systems
UOC	Uranium ore concentrate

UOSB	Ultrasonic Optical Sealing Bolt
UQ	uncertainty quantification
USV	Unmanned Surface Vehicle
UWA	University of Western Australia
UWB	Ultra-Wideband
VIC	Vienna International Centre
VPN	Virtual Private Network
VSP	Visual Sampling Plan
WWER	water-water energetic reactor
XCVD	next generation of Cerenkov Viewing Device
XRF	X-ray fluorescence spectrometry

